

DOCUMENTATION

ELECTRONIC MIXING MACHINE

**PU 3000
2L 30/1**

Manual : 582.002.110-UK - 2307 - Index A

Date : 17/07/23

Supersede : 28/03/22

Modif.: Update

TRANSLATION FROM THE ORIGINAL MANUAL

IMPORTANT : Before assembly and start-up, please read and clearly understand all the documents relating to this equipment (professional use only).

THE PICTURES AND DRAWINGS ARE NON CONTRACTUAL. WE RESERVE THE RIGHT TO MAKE CHANGES WITHOUT PRIOR NOTICE.

SAMES KREMLIN SAS

13, chemin de Malacher
38 240 - MEYLAN - France

 : 33 (0)4 76 41 60 60

www.sames-kremlin.com



<p align="center">FR</p> <p><u>Pour une utilisation sûre, il est de votre responsabilité de :</u></p> <ul style="list-style-type: none"> • Lire attentivement tous les documents contenus dans le CD joint avant la mise en service de l'équipement, • D'installer, d'utiliser, d'entretenir et de réparer l'équipement conformément aux préconisations de SAMES KREMLIN ainsi qu'aux réglementations nationales et/ou locales, • Vous assurez que les utilisateurs de cet équipement ont été formés, ont parfaitement compris les règles de sécurité et qu'ils les appliquent. 	<p align="center">UK</p> <p><u>To ensure safe use of the machinery, it is your responsibility to:</u></p> <ul style="list-style-type: none"> • Carefully read all documents contained on the enclosed CD before putting the machinery into service, • Install, use, maintain and repair the machinery in accordance with SAMES KREMLIN's recommendations and national and/or local regulations, • Make sure that the users of the machinery have received proper training and that they have perfectly understood the safety rules and apply them. 	<p align="center">DE</p> <p><u>Eine sichere Nutzung setzt voraus, dass Sie :</u></p> <ul style="list-style-type: none"> • alle in der CD enthaltenen Dokumente vor der Inbetriebnahme der Anlage aufmerksam lesen, • die Anlage im Einklang mit den Empfehlungen von SAMES KREMLIN sowie mit den nationalen und/oder lokalen Bestimmungen installieren, verwenden, warten und reparieren, • sich vergewissern, dass die Nutzer dieser Anlage angemessen geschult wurden, die Sicherheitsbestimmungen verstanden haben und sie anwenden.
<p align="center">ES</p> <p><u>Para una utilización segura, será de su responsabilidad:</u></p> <ul style="list-style-type: none"> • leer atentamente todos los documentos que se incluyen en el CD adjunto antes de la puesta en servicio del equipo, • instalar, utilizar, efectuar el mantenimiento y reparar el equipo con arreglo a las recomendaciones de SAMES KREMLIN y a la normativa nacional y/o local, • cerciorarse de que los usuarios de este equipo han recibido la formación necesaria, han entendido perfectamente las normas de seguridad y las aplican. 	<p align="center">IT</p> <p><u>Per un uso sicuro, vi invitiamo a:</u></p> <ul style="list-style-type: none"> • leggere attentamente tutta la documentazione contenuta nel CD allegato prima della messa in funzione dell'apparecchio, • installare, utilizzare, mantenere e riparare l'apparecchio rispettando le raccomandazioni di SAMES KREMLIN, nonché le normative nazionali e/o locali, • accertarvi che gli utilizzatori dell'apparecchio abbiano ricevuto adeguata formazione, abbiano perfettamente compreso le regole di sicurezza e le applichino. 	<p align="center">PT</p> <p><u>Para uma utilização segura, é da sua responsabilidade:</u></p> <ul style="list-style-type: none"> • Ler atentamente todos os documentos incluídos no CD em anexo antes de pôr o equipamento em funcionamento, • Proceder à instalação, utilização, manutenção e reparação do equipamento de acordo com as preconizações de SAMES KREMLIN, bem como com outros regulamentos nacionais e/ou locais aplicáveis, • Assegurar-se que os utilizadores do equipamento foram devidamente capacitados, compreenderam perfeitamente e aplicam as devidas regras de segurança.
<p align="center">NL</p> <p><u>Voor een veilig gebruik dient u:</u></p> <ul style="list-style-type: none"> • alle document op de bijgevoegde cd aandachtig te lezen alvorens het apparaat in werking te stellen, • het apparaat te installeren, gebruiken, onderhouden en repareren volgens de door SAMES KREMLIN gegeven aanbevelingen en overeenkomstig de nationale en/of plaatselijke reglementeringen, • zeker te stellen dat de gebruikers van dit apparaat zijn opgeleid, de veiligheidsregels perfect hebben begrepen en dat zij die ook toepassen. 	<p align="center">SE</p> <p><u>För en säker användning av utrustningen ansvarar ni för följande:</u></p> <ul style="list-style-type: none"> • Läs noga samtliga dokument som finns på den medföljande cd-skivan innan utrustningen tas i drift. • Installera, använd, underhåll och reparera utrustningen enligt anvisningarna från SAMES KREMLIN och enligt nationella och/eller lokala bestämmelser. • Försäkra er om att användare av denna utrustning erhållit utbildning, till fullo förstått säkerhetsföreskrifterna och tillämpar dem. 	<p align="center">FI</p> <p><u>Käytön turvallisuuden varmistamiseksi velvollisuutesi on:</u></p> <ul style="list-style-type: none"> • Lukea huolella kaikki CD:llä olevat asiakirjat ennen laitteiston käyttöönottoa, • Noudata laitteiston asennuksessa, käytössä, kunnossapidossa ja huollossa SAMES KREMLIN in suosituksia sekä kansallisia ja/tai paikallisia määräyksiä, • Varmistaa, että laitteiston käyttäjät ovat koulutettuja ja ymmärtävät täysin turvallisuusmääräykset ja miten niitä sovelletaan.
<p align="center">PL</p> <p><u>Dla zapewnienia bezpiecznego użytkowania na użytkownika spoczywa obowiązek:</u></p> <ul style="list-style-type: none"> • Uważnego zapoznania się ze wszystkimi dokumentami znajdującymi się na załączonej płycie CD przed pierwszym uruchomieniem urządzenia, • Instalowania, użytkowania, konserwacji i naprawy urządzenia zgodnie z zaleceniami firmy SAMES KREMLIN oraz z przepisami miejscowymi, • Upewnienia, że wszyscy przeszkoleni użytkownicy urządzenia zrozumieli zasady bezpieczeństwa i stosują się do nich. 	<p align="center">CS</p> <p><u>Pro bezpečné používání jste povinni:</u></p> <ul style="list-style-type: none"> • Před uvedením zařízení do provozu si pozorně přečíst veškeré dokumenty obsažené na příloženém CD, • Nainstalovat, používat, udržovat a opravovat zařízení v souladu s pokyny firmy SAMES KREMLIN a s národními a/nebo místními legislativními předpisy, • Ujistit se, že uživatelé tohoto zařízení byli vyškoleni, že dokonale pochopili bezpečnostní pravidla a že je dodržují. 	<p align="center">SL</p> <p><u>Za varno uporabo ste dolžni:</u></p> <ul style="list-style-type: none"> • natančno prebrati vse dokumente na CD pred zagonom stroja, • inštalirati, uporabljati, vzdrževati in popravljati opremo po določilih SAMES KREMLIN in v skladu z veljavnimi nacionalnimi in/ali lokalnimi predpisi, • poskrbeti, da so uporabniki te opreme ustrezno usposobljeni, poznajo varnostne predpise in da jih upoštevajo.
<p align="center">SK</p> <p><u>V záujme bezpečného je vašou povinnosťou:</u></p> <ul style="list-style-type: none"> • pozorne si prečítať všetky dokumenty obsiahnuté na priloženom CD predtým, ako zariadenie uvediete do prevádzky, • nainštalovať, používať, udržiavať a opravovať zariadenie v súlade s odporúčaniami spoločnosti SAMES KREMLIN a národnými a/alebo miestnymi predpismi, • uistiť sa, že používatelia tohto zariadenia boli zaškolení, riadne porozumeli pravidlám bezpečnosti a používajú ich. 	<p align="center">HU</p> <p><u>A biztonságos használat érdekében az Ön felelőssége, hogy:</u></p> <ul style="list-style-type: none"> • a berendezés üzembe helyezése előtt figyelmesen elolvassa a mellékelt CD által tartalmazott összes dokumentumot, • a berendezést a SAMES KREMLIN ajánlásainak valamint a nemzeti és/vagy helyi szabályzásoknak megfelelően helyezze üzembe, használja, tartsa karban és javítsa, • megbizonyosodjon róla, hogy a berendezés felhasználói képzettek, tökéletesen megértették és alkalmazzák a biztonsági előírásokat. 	<p align="center">RO</p> <p><u>Pentru o utilizare sigură, este responsabilitatea dvs. să:</u></p> <ul style="list-style-type: none"> • Citiți cu atenție toate documentele de pe CD-ul anexat, înainte de punerea în funcțiune a echipamentului, • Instalați, utilizați, întrețineți și reparați echipamentul conform instrucțiunilor SAMES KREMLIN precum și reglementărilor naționale și/sau locale, • Vă asigurați că utilizatorii acestui echipament au fost instruiți, au înțeles perfect regulile de securitate și le aplică integral.

Declaration(s) de conformité au verso de ce document / Declaration(s) of conformity at the back of this document / Konformitätserklärung(en) auf der Rückseite dieser Unterlage / Declaración (es) de conformidad en el reverso de este documento / Dichiarazione/i di conformità sul retro del presente documento / Declaração(ões) de conformidade no verso do documento / Conformiteitsverklaring(en) op de keerzijde van dit document / Försäkran om överensstämmelse på omstående sida av detta dokument / Vaatimustenmukaisuusvakuutukset tämän asiakirjan kääntöpuolella / Deklaracja(e) zgodności na odwrocie dokumentu / Prohlášení o shodě se nachází/nacházejí na zadní straně tohoto dokumentu / Deklaracija(e) o skladnosti na hrbtni strani tega dokumenta / Vyhlášení/-a o zhode sa nachádzajú na zadnej strane dokumentu / A dokumentum hátlapján szereplő megfelelőségi nyilatkoz(ok) / Declarații de conformitate pe versoul acestui document



DECLARATION D'INCORPORATION
DECLARATION OF INCORPORATION
EINBAUERKLÄRUNG
DECLARACIÓN DE INCORPORACIÓN
DICHIARAZIONE DI INCORPORAZIONE
DECLARAÇÃO DE INCORPORAÇÃO
INBOUWVERKLARING BETREFFENDE
FÖRSÄKRAN FÖR INBYGGNAD
PUOLIVALMISTEIDEN LIITTÄMISVAKUUTUS
DEKLARACJA WŁACZENIA
PROHLÁŠENÍ O ZABUDOVÁNÍ
DEKLARACIJA O VGRADNJI
VYHLÁŠENIE O ZAČLENENÍ
BEÉPÍTÉSI NYILATKOZAT
DECLARATIE DE ÎNCORPORARE

Le fabricant / The manufacturer / Der Hersteller / El fabricante / Il produttore / O fabricante / De fabrikant / Tillverkare / Valmistaja / Producent / Výrobce / Proizvajalec / Výrobca / Gyártó / Fabricantul:	SAMES KREMLIN SAS 13, chemin de Malacher 38 240 - MEYLAN - FRANCE Tél. : 33 (0)4 76 41 60 60
---	--

Déclare que le matériel désigné ci-après / Herewith declares that the equipment / erklårt hiermit, dass die / Declara que el material designado a continuación / Dichiaro che il materiale sottoindicato / Declara que o material a seguir designado / verklaart dat de hieronder aangeduide apparatuur / Kungör att den utrustning som anges här nedan / ilmoittaa, että alla mainitut laitteistot / Oświadcza, że wymienione poniżej urządzenia / Prohlašuje, že níže uvedené vybavení / Izjavlja, da je opisana oprema spodaj / Vyhlasuje, že zariadenie uvedené nižšie / Kijelenti, hogy a megjelölt anyag a továbbiakban / Declară că echipamentul precizat mai jos:

MACHINE DE DOSAGE BI-COMPOSANT/ TWO-COMPONENT PROPORTIONING MACHINE
ELEKTRONISCHE 2-K ANLAGE / MÁQUINA DE DOSIFICACIÓN DOS COMPONENTES

PU 3000

Est conforme à la législation d'harmonisation de l'Union applicable suivante / Is in conformity with the relevant Union harmonisation legislation / Erfüllt die einschlägigen Harmonisierungsrechtsvorschriften der Union / es conforme con la legislación de armonización pertinente de la Unión / è conforme alla pertinente normativa di armonizzazione dell'Unione / in overeenstemming met de desbetteffende harmonisatiewetgeving van de Unie / med den relevanta harmoniserade unionslagstiftningen / on asiaa koskevan unionin yhdenmukaistamislainsäädännön vaatimusten mukainen / jest zgodny z odnośnymi wymaganiami unijnego prawodawstwa harmonizacyjnego / Shoduje se s následující příslušnou evropskou harmonizační legislativou / V skladu s harmonizirano zakonodajjo Unije / Je v súlade s uplatniteľnými harmonizačnými právnymi predpismi EÚ / Megfelel a következő alkalmazandó uniós harmonizációs szabályozásnak / Este conform cu legislația aplicabilă de armonizare de mai jos

Cette quasi-machine ne doit pas être mise en service avant que la machine finale dans laquelle elle doit être incorporée ait été déclarée conforme à la directive Machines 2006/42/CE / This partly completed machinery must not be put into service until the final machinery in which it is to be incorporated has been declared in conformity with Directive 2006/42/CE on Machinery / Die unvollständige Maschine darf erst in Betrieb genommen werden, wenn für die fertige Maschine, in die sie eingebaut werden soll, eine Konformitätserklärung mit der Maschinenrichtlinie 2006/42/CE vorliegt / Esta cuasi máquina no deberá ser puesta en servicio mientras la máquina final en la cual vaya a ser incorporada no haya sido declarada conforme a la Directiva 2006/42/CE relativa a las máquinas / Questa quasi-macchina non deve essere messa in servizio finché la macchina finale in cui deve essere incorporata non è stata dichiarata conforme alla direttiva macchine 2006/42/CE / Esta quase-máquina só deve ser posta em funcionamento quando a máquina final na qual deve ser incorporada tiver sido declarada em conformidade com as disposições pertinentes do anexo I da Directiva 2006/42/CE relativa às Máquinas / Deze niet voltooide machine mag niet in dienst worden genomen voordat de afgewerkte machine, waarin zij moet worden ingebouwd, conform is verklaard aan de Machineryrichtlijn 2006/42/CE / Denna delvis fullbordade maskin får inte tas i drift innan den slutliga maskin i vilken den ska byggas in försäkrats överensstämma med maskindirektivet, 2006/42/CE / Tätä puolivalmistetta ei saa ottaa käyttöön ennen kuin lopullisen koneen, johon se on määrä liittää, on ilmoitettu olevan konedirektiivin 2006/42/EY mukainen / Niniejszej maszyny nieukończonej nie można uruchomić bez uzyskania deklaracji zgodności z dyrektywą Maszynową 2006/42/WE dla maszyny, której ma być częścią. / Toto neúplné strojní zařízení nesmí být uvedeno do provozu, dokud nebude strojní zařízení, do kterého je začleňováno, prohlášeno za shodné podle Směrnice 2006/42/ES o strojních zařízeních / Tega delno dokončane stroja ni dovoljeno zagnati, dokler ni potrjena skladnost z Direktivo o strojih 2006/42/ES končnega stroja, v katerega je nameščen delno dokončan stroj. / Takéto neúplné strojové zariadenie môže byť uvedené do prevádzky až keď konečné strojové zariadenie, do ktorého má byť začlenené, bude vyhlásené za zhodné so smernicou o strojových zariadeniach 2006/42/ES / A részben kész gépet addig nem szabad üzembe helyezni, amíg arról a kész gépről, amelybe beépítik, el nem készült a 2004/42/EK irányelv rendelkezéseinek való megfelelésegről szóló nyilatkozat / Acest echipament tehnic parțial finalizat nu trebuie pus în funcțiune înainte ca echipamentul final în care acesta trebuie încorporat să fie declarat conform Directivei utilaje 2006/42/CE.

Philippe PROVENAZ

Directeur Innovation & Développement / Innovation & Development
Director / Direktor für Innovation & Entwicklung / Director de
Inovación y Desarrollo / Direttore Innovazione e sviluppo
/ Diretor de Inovação / Manager Innovatie en Ontwikkeling / Direktör
för Forskning och Utveckling / Innovaatio- ja kehitysohjaaja
/ Dyrektor ds. Innowacji i Rozwoju / Ředitel pro inovace a vývoj
/ Direktor za inovacije in razvoj / Riaditeľ pre inováciu a rozvoj
/ Innovációs és fejlesztési igazgató / Director Inovație și Dezvoltare

Fait à Meylan, le / Established in Meylan, on / Geschehen zu Meylan, am / En Meylan, a / Redatto a Meylan, / Vastgesteld te Meylan, / Utformat i Meylan, den / Meylan, Ranska, / Sporządzono w Meylan, dnia / Meylan, dnia / V Meylanu, / V Meylan dňa / Kelt Meylanban, / Întocmită la Meylan, pe data de 01/02/2017 - 02/01/2017



DECLARATION UE DE CONFORMITE
UE DECLARATION OF CONFORMITY
EU- KONFORMITÄTSEKTLÄRUNG
DECLARACIÓN UE DE CONFORMIDAD
DICHIARAZIONE DI CONFORMITÀ UE
DECLARAÇÃO UE DE CONFORMIDADE
EU-CONFORMITEITSVERKLARING
EU-FÖRSÄKRAN OM ÖVERENSSTÄMMELSE
EU- VAATIMUKSEN MUKAISUUSVAKUUTUS
DEKLARACJA ZGODNOŚCI UE
EU PROHLÁŠENÍ O SHODĚ
IZJAVA EU O SKLADNOSTI
VYHLÁSENIE O ZHODE
EU-MEGFELELŐSÉGI NYILATKOZAT
DECLARAȚIA DE CONFORMITATE UE



Le fabricant / The manufacturer / Der Hersteller / El fabricante / Il produttore / O fabricante / De fabrikant / Tillverkare / Valmistaja / Producent / Výrobce / Proizvajalec / Výrobca / Gyártó / Fabricantul:	SAMES KREMLIN SAS 13, chemin de Malacher 38 240 - MEYLAN - FRANCE Tél. : 33 (0)4 76 41 60 60
---	--

Déclare que le matériel désigné ci-après / Herewith declares that the equipment / erklårt hiermit, dass die / Declara que el material designado a continuación / Dichiaro che il materiale sottoindicato / Declara que o material a seguir designado / verklaart dat de hieronder aangeduide apparatuur / Kungör att den utrustning som anges här nedan / ilmoittaa, että alla mainitut laitteistot / Oświadczam, że wymienione poniżej urządzenia / Prohlašuje, že níže uvedené vybavení / Izjavlja, da je opisana oprema spodaj / Vyhlasuje, že zariadenie uvedené nižšie / Kijelenti, hogy a megjelölt anyag a továbbiakban / Declară că echipamentul precizat mai jos:

MACHINE DE DOSAGE BI-COMPOSANT/ TWO-COMPONENT PROPORTIONING MACHINE
ELEKTRONISCHE 2-K ANLAGE / MÁQUINA DE DOSIFICACIÓN DOS COMPONENTES

PU 3000

Est conforme à la législation d'harmonisation de l'Union applicable suivante / Is in conformity with the relevant Union harmonisation legislation / Erfüllt die einschlägigen Harmonisierungsrechtsvorschriften der Union / es conforme con la legislación de armonización pertinente de la Unión / è conforme alla pertinente normativa di armonizzazione dell'Unione / in overeenstemming met de desbetteffende harmonisatiewetgeving van de Unie / med den relevanta harmoniserade unionslagstiftningen / on asiaa koskevan unionin yhdenmukaistamislainsäädännön vaatimusten mukainen / jest zgodny z odnośnymi wymaganiami unijnego prawodawstwa harmonizacyjnego / Shoduje se s následující příslušnou evropskou harmonizační legislativou / V skladu s harmonizirano zakonodajo Unije / Je v súlade s uplatniteľnými harmonizačnými právnymi predpismi EÚ / Megfelel a következő alkalmazandó uniós harmonizációs szabályozásnak / Este conform cu legislația aplicabilă de armonizare de mai jos

Directive Basse Tension / Low Voltage Directive / Niederspannung-Richtlinie / Directiva Baja Tensión / Direttiva Bassa Tensione / Directiva de Baixa Tensão / Richtlijn Laagspanning / Lågspänningsdirektivet / Pienjännitedirektiivi / Dyrektywa Niskonapięciowa / Směrnice Pro Nizké Napětí / Direktiva O Nizki Napetosti / Smernica O Nizkom Napätí / Feszültséghatárna Vonatkozó Irányelv / Directiva Privind Tensiunile Joase EN 60204-1:2006 + A1:2009	2014/35/UE								
Directive Compatibilité Electromagnétique / Electromagnetic Compatibility Directive / Richtlinie Für Elektromagnetische Verträglichkeit / Directiva de Compatibilitad Eletromagnética / Direttiva Compatibilita Eletromagnetica / Directiva relativa à Compatibilidade Eletromagnética / Richtlijn Elektromagnetische Compatibiliteit / Direktivet om Elektromagnetisk Kompatibilitet / EMC-direktivi / Dyrektywa Kompatybilności Elektromagnetycznej / Směrnice Pro Elektromagnetickou Kompatibilitu / Direktiva O Elektromagnetni Združljivost / Smernica O Elektromagnetickej Kompatibilite / Az Elektromágneses Összeférhetőségre vonatkozó Irányelv / Directiva Privind Compatibilitatea Electromagnetică EN 61000-6-2:2005 EN 61000-6-3:2007 + A1:2011	2014/30/UE								
Directive ATEX / ATEX Directive / ATEX Richtlinie / Directiva ATEX / Direttiva ATEX / Diretiva ATEX / ATEX-Richtlijn / ATEX-direktivet / ATEX-direktivi / Dyrektywa ATEX / Směrnice ATEX / Direktiva ATEX / Smernica ATEX / ATEX-irányelv Marquage Coffret de commande / Marking control box :  II 2G [EEx ia] IIA Marquage Platine produit / Marking fluid module :  II 2G IIA T3 Tous les composants électriques utilisés en zone 1 sont, individuellement conformes à la directive 2014/34/UE. Leur présence combinée au sein de l'assemblage ne met pas en évidence de risques supplémentaires entraînant une évaluation globale de type de la machine. / Each individual electrical component used in zone 1 is in conformity with the 2014/34/UE directive. Their combined presence in the assembly has not highlighted any additional risks that would necessitate a comprehensive assesment of this type of machinery.	2014/34/UE								
<table border="1"><thead><tr><th>Matériel / Equipment</th><th>N° d'agrément / Approval N°</th></tr></thead><tbody><tr><td>Barrière Zener / Zener barrier</td><td>BAS 01 ATEX 7005</td></tr><tr><td>Electrovanne / Electrovalve ATEX</td><td>LCIE 12 ATEX 3005 X</td></tr><tr><td>Electrovanne / Electrovalve</td><td>DEKRA 11 ATEX 0091 X</td></tr></tbody></table>	Matériel / Equipment	N° d'agrément / Approval N°	Barrière Zener / Zener barrier	BAS 01 ATEX 7005	Electrovanne / Electrovalve ATEX	LCIE 12 ATEX 3005 X	Electrovanne / Electrovalve	DEKRA 11 ATEX 0091 X	
Matériel / Equipment	N° d'agrément / Approval N°								
Barrière Zener / Zener barrier	BAS 01 ATEX 7005								
Electrovanne / Electrovalve ATEX	LCIE 12 ATEX 3005 X								
Electrovanne / Electrovalve	DEKRA 11 ATEX 0091 X								

La présente déclaration de conformité est établie sous la seule responsabilité du fabricant / This declaration of conformity is issued under the sole responsibility of the manufacturer / Die alleinige Verantwortung für die Ausstellung dieser Konformitätserklärung trägt der Hersteller / La presente declaración de conformidad se expide bajo la exclusiva responsabilidad del fabricante / La presente dichiarazione di conformità è rilasciata sotto la responsabilità esclusiva del fabbricante / A presente declaração de conformidade é emitida sob a exclusiva responsabilidade do fabricante / Deze conformiteitsverklaring wordt verstrekt onder volledige verantwoordelijkheid van de fabrikant / Denna försäkran om överensstämmelse utfärdas på tillverkarens eget ansvar / Tämä vaatimustenmukaisuusvakuutus on annettu valmistajan yksinomaisella vastuulla / Niniejsza deklaracja zgodności wydana zostaje na wyłączną odpowiedzialność producenta / Toto prohlášení o shodě se vydává na výhradní odpovědnost výrobce / Za izdajo te izjave o skladnosti je odgovoren izključno proizvajalec / Toto vyhlásenie o zhode sa vydáva / na vlastnú zodpovednosť výrobcu / Ezt a megfelelőségi nyilatkozatot a gyártó kizárólagos felelőssége mellett adják ti / Prezenta declarație de conformitate este emisă pe răspunderea exclusivă a producătorului.



Philippe PROVENAZ

Directeur Innovation & Développement / Innovation & Development
Director / Direktor für Innovation & Entwicklung / Director de
Inovación y Desarrollo / Direttore Innovazione e sviluppo
/ Diretor de Inovação / Manager Innovatie en Ontwikkeling / Direktör
för Forskning och Utveckling / Innovaatio- ja kehitysjohtaja
/ Dyrektor ds. Innowacji i Rozwoju / Ředitel pro inovace a vývoj
/ Direktor za inovacije in razvoj / Riaditeľ pre inováciu a rozvoj
/ Innovációs és fejlesztési igazgató / Director Inovație și Dezvoltare

Fait à Meylan, le / Established in Meylan, on / Geschehen zu Meylan, am / En Meylan, a / Redatto a Meylan, / Vastgesteld te Meylan, / Utformat i
Meylan, den / Meylan, Ranska, / Sporządzono w Meylan, dnia / Meylan, dnia / V Meylanu, / V Meylan dňa / Kelt Meylanban, / Întocmită la Meylan,
pe data de 01/02/2017 - 02/01/2017



INSTALLATION AND SAFETY INSTRUCTIONS

TRANSLATION FROM THE ORIGINAL MANUAL

IMPORTANT : Before assembly and start-up, please read and clearly understand all the documents relating to this equipment (professional use only).

THE PICTURES AND DRAWINGS ARE NON CONTRACTUAL. WE RESERVE THE RIGHT TO MAKE CHANGES WITHOUT PRIOR NOTICE.

SAMES KREMLIN SAS
13, chemin de Malacher
38 240 - MEYLAN - France
☎ : 33 (0)4 76 41 60 60

www.sames-kremlin.com

1. SAFETY INSTRUCTIONS

GENERAL SAFETY INSTRUCTIONS



CAUTION : The equipment can be dangerous if you do not follow our instructions concerning installation and servicing described in this manual and in accordance with applicable European standards and local national safety regulations.

Please carefully read all the instruction literature before operating your equipment.

Only trained operators can use the equipment.

The foreman must ensure that the operator has understood the safety instructions for this equipment as well as the instructions in the manuals for the different parts and accessories.

Read carefully all instruction manuals, label markings before operating the equipment.

Incorrect use may result in injury. This equipment is for professional use only. It must be used only for what it has been designed for. Never modify the equipment. The parts and accessories supplied must be regularly inspected. Defective or worn parts must be replaced.







Guards (motor cover, coupling shields, connectors,...) have been designed for a safe use of the equipment.

The manufacturer will not be held responsible for bodily injury or failure and / or property damage due to destruction, the overshadowing or the partial or total removal of the guards.

Never exceed the equipment components' maximum working pressure.

Comply with regulations concerning safety, fire risks, electrical regulations in force in the country of final destination of the material. Use only products or solvent compatible with the parts in contact with the material (refer to data sheet of the material manufacturer).

PICTOGRAMS

					
NIP HAZARD	WARNING MOVING ELEVATOR	WARNING MOVING PARTS	WARNING MOVING SHOVEL	DO NOT EXCEED THIS PRESSURE	HIGH PRESSURE HAZARD
					
RELIEF OR DRAIN VALVE	WARNING HOSE UNDER PRESSURE	WEAR GLASSES OBLIGATORY	WEAR OF GLOVES IS OBLIGATORY	PRODUCT VAPOR HAZARDS	WARNING HOT PARTS OR AREAS
					
ELECTRICAL HAZARD	WARNING FIRE HAZARDS	EXPLOSION HAZARDS	GROUNDING	WARNING (USER)	WARNING SERIOUS INJURIES

PRESSURE HAZARDS



Current legislation requires that an **air relief valve** be fitted in the air supply circuit to the air motor to prevent over pressurisation. This safety feature, ensures that it is not possible to supply the air motor with excessive air pressure that may cause injury.

Please ensure that a **material drain valve** is fitted in the fluid circuit to drain and depressurise the circuit. Once depressurised and drained, work /servicing may then commence on the equipment. Please remember to close these valves when restarting the system.

HIGH PRESSURE INJECTION HAZARDS



When working with high pressure equipment, special care is required. Fluid leaks can occur. There is a risk of material being injected to any exposed parts of body, this could cause severe injury :



- medical care must be sought immediately if paint is injected under the skin or in other parts of the body (eyes, fingers).
- never point the spray gun at any one. Never try to stop the spray with your hands or fingers nor with rags or similars.
- **follow the shut down procedure and always depressurize air and fluid circuits** before carrying out any servicing on the gun (cleaning, checking, maintenance of the material or cleaning of the gun nozzles).
- for the guns equipped with a safety device, always lock the trigger when not in use.

FIRE - EXPLOSION - SPARKS - STATIC ELECTRICITY HAZARDS



A poor earth connection, inadequate ventilation, sparks or static electricity can cause an explosion or fire. to avoid these risks when using or servicing SAMES KREMLIN equipment, the following safety procedures must be followed :



- ensure a good earth connection and ground the parts to be handled i.e. solvents, materials, components and equipment,
- ensure adequate ventilation,
- keep working area clean and free from waste solvents, chemicals, or solid waste i.e. rags, paper and empty chemicals drums,
- never use electrical switches / power if in an atmosphere of volatile solvent vapour,
- stop working immediately in case of electrical arcs,
- never store chemicals and solvents in the working area.
- use paint whose flash point is the highest possible to prevent from any formation of gas and inflammable vapours (refer to materials' safety instructions),
- install a cover on the drums to reduce the diffusion of gas and vapours in the spraybooth.

TOXIC PRODUCT HAZARDS



Toxic products or vapours can cause severe injury not only through contact with the body, but also if the products are ingested or inhaled. It is imperative :



- to know the material products and their risks,
- notified or hazardous materials must be stored in accordance with the regulations,
- the material must be stored in an appropriate container, never place materials in a container where there is a risk of spillage or leakage,
- a procedure must be applied for the safe disposal of waste material. It must comply with all prevailing regulations and legislations of the country where the equipment is to be used,
- protective clothing should always be worn in compliance with the material manufacturers' recommendations,
- depending on the application and chemical safety instructions, safety glasses, hearing protective earplug, gloves, foot wear, protective masks and possible breathing equipment should be worn to comply with the regulations (Refer to chapter "Safety equipment of SAMES KREMLIN selection guide).



CAUTION!

It is forbidden to use material containing high concentrations of halogenated hydrocarbon solvents with **aluminium** or **zinc fillers**. Non-compliance with the instructions may cause explosion risk causing serious or fatal injury.



EQUIPMENT REQUIREMENTS

Guards (motor cover, coupling shields, connectors,...) have been designed for a safe use of the equipment.

The manufacturer will not be held responsible for bodily injury or failure and / or property damage due to destruction, the overshadowing or the partial or total removal of the guards.

PUMP



Before carrying out any work, it is imperative to read and clearly understand the disassembly and reassembly instructions before servicing. The operator must understand the equipment and the safety instructions. These instructions are available in the equipment manuals.



The air motor is designed to be mounted with a pump. Never modify any components or couplings. When operating, please keep hands away from moving parts. Before starting up the equipment, please read the PRESSURE RELIEF instructions. Please ensure that any relief or drain valves fitted are in good working order.

HOSES

- Keep hoses out of circulation areas, moving parts or hot surfaces,
- Never expose product hoses to temperature higher than + 60°C / 140° F or lower than 0°C / 32° F,
- Never pull or use the hoses to move the equipment,
- Tighten all fittings as well as the hoses before operating the equipment,
- Check the hoses regularly; change them if they are damaged,
- Never exceed the maximum working pressure (MWP) indicated on the hose.

USED PRODUCTS

Considering the wide variety of products that are available and can be used in our equipment it is impossible to check and make recommendations for all chemical data, regarding the risks of possible chemical attack and their long term chemical reaction

SAMES KREMLIN can not be held liable for :

- compatibility of wetted parts,
- risks to staff and the surroundings,
- for worn or defective parts, for faulty equipment or units, or the quality of final product.

It is the responsibility of the user to know and prevent any possible risks such as toxic vapours, fires or explosions. He shall determine the risks of immediate reactions or pursuant to repeated exposures of the staff,

SAMES KREMLIN shall not be liable for physical injuries, direct or indirect material damages caused by the use of chemicals.

2. HANDLING



Check the weight and the dimensions of the equipment
(☞ refer to 'Technical features' section of the instruction manual)

If weight and dimensions are too important, the unloading must be carried out by means of a forklift or any other appropriate means with a qualified personnel and in a clear horizontal area to prevent from risks of damage injury or an accident.

The centre of gravity is not in the centre of the machine : carry out by hand a stability-test after having lifted the whole at 10 cm / 3.937" maximum.

After the unloading, the handling of the whole (eg: elevator pump) is carried out by means of a pallet truck taking the bottom part of the frame.

Remark : Each pump motor is fitted with a ring. The ring is designed for the hoisting of one pump and can not be used for the handling of the complete assembly.

3. STORING

Storing before installation :

- Storing ambient temperature : 0 / +50 °C / 0 / +122°F
- Protect the whole against dust, water trickling, dampness and shocks.

Storing after installation :

- Operating temperature : +15 / +35 °C / +59 / +138.2° F
- Protect the whole against dust, water trickling, dampness and shocks.

4. INSTALLATION OF THE EQUIPMENT

The machine is installed on a stable horizontal floor (for eg a concrete flag).

The machine shall be made stable by the use of holding down bolts or by the use of other anchoring methods, strong enough to prevent unintended bodily movement of the equipment.



To avoid risks caused by static electricity, the equipment as well as its components must be grounded.

- **For the pumping equipments** (pumps, pneumatic rams, frame...), a section wire of 2.5 mm² is fixed on the material. Use this wire to connect the material to "the general ground". In case of severe environments (mechanical protection of the wire of earthing insufficient, vibrations, mobile material...) where function damages at the ground are probable, the user have to replace the provided wire of 2.5 mm² by a device more adapted to its environment (wire with a more important section, bonding strip, fixing by thimble with eyelet...).

The continuity of the ground must be controlled by a qualified electrician. If the continuity of the ground is not ensured, check the terminal, the wire and the earthing point. **Never** use the material without have solved this problem.

- In the severe cases of environments (mechanical protection of the wire of earthing insufficient, vibrations, mobile material...) where damages of the function put at the ground are probable, the user will have to replace the wire of 2.5 mm² provided, by a device more adapted to its environment (wire of more important section, bonding strip, fixing by thimble with eyelet...),
- **The gun** must be 'grounded' via a material hose or an air hose. In case of spraying by means of a gun with cup, the air hose must be conductive,
- **The materials to be painted** must also be grounded.

All the materials situated in the working area shall be grounded.



- **Never store** more than necessary inflammable materials inside the working area,
- The materials must be stored into **approved drums** and grounded,
- Use only grounded **metals containers** for the use of cleaning solvents,
- **Cardboard and paper are prohibited.**

5. MARKING OF THE EQUIPMENT



Each equipment has a label plate with the name of the manufacturer, the equipment part number, the interesting informations to use correctly the equipment (pressure, voltage,...) and sometimes the above pictogram.

The equipment is designed with and consists of high quality materials and components which can be re-used.

The 2012/19/UE European Directive covers all equipments with a crossed-out bin pictogram. Please inform yourself about the collection systems for electric and electronic equipments.

Please act in accordance with local rules and **do not dispose of old equipment with household wastes**. A correct disposal of old equipment will help prevent negative consequences for the environment and health.

INSTRUCTION MANUAL ELECTRONIC MIXING MACHINE PU 3000

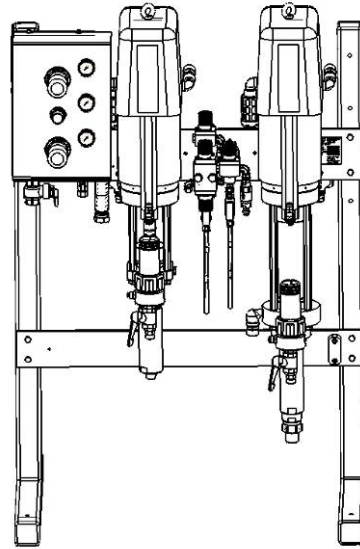

Manual : 2203 573.199.112

Date : 14/03/22 - Cancels : 02/11/21

Modif. : Motor 1500 → Motor 1000

TRANSLATION FROM THE ORIGINAL MANUAL

IMPORTANT : Before assembly and start-up, please read and clearly understand all the documents relating to this equipment (professional use only).

THE PICTURES AND DRAWINGS ARE NON CONTRACTUAL. WE RESERVE THE RIGHT TO MAKE CHANGES WITHOUT PRIOR NOTICE.

SAMES KREMLIN SAS
13, chemin de Malacher
38 240 - MEYLAN - France
 : 33 (0)4 76 41 60 60
www.sames-kremlin.com

TABLE OF CONTENTS

1.	SAFETY INSTRUCTIONS	6
■	SPECIFIC SAFETY INSTRUCTIONS	6
■	ENVIRONMENT	7
■	ELECTROSTATIC INSTALLATION	7
2.	DESCRIPTION	8
3.	OPERATING DESCRIPTION	10
4.	FEATURES	10
5.	INSTALLATION	11
■	HANDLING	11
■	STORAGE	11
■	ENVIRONMENT ON THE AREA	11
■	DESCRIPTION OF THE LABEL MARKINGS	12
■	INSTALLATION DIAGRAM	14
■	INSTALLATION	15
■	CONNECTION OF THE CONTROL BOX AND OF THE FLUID FRAME	16
6.	OPERATING	17
■	DRIVING FROM THE MACHINE	17
■	SWITCHING ON THE MACHINE	17
7.	FIRST SWITCHING ON	18
8.	FIRST PLACING INTO OPERATION	19
■	BEFORE SWITCHING ON	19
■	FLUSHING OF THE PUMPS AND OF THE MACHINE IN SOLVENT	19
■	START UP OF THE MACHINE	20
■	MIXING RATIO CHECKING	20
9.	APPLICATION PROGRAMMING (F3)	22
■	PASSWORD	22
■	PROCEDURE TO GET THE VERSION NUMBER OF THE ELECTRONIC CARD	22
■	PARAMETERS	23
■	VALIDATION OF THE INITIALIZATION MODE	25
■	PRODUCTION (F1)	26
■	FLUSHING (F2)	27
■	CONSUMPTIONS / PRINT (F4)	27
■	DOWNLOADING DATA FROM PU 3000 TO A COMPUTER	29
■	DRUM REPLACEMENT PROCEDURE	33
10.	INDICATIONS OF OPERATION GIVEN BY THE MACHINE	34
■	INDICATIONS GIVEN BY THE LEDS	34
■	MESSAGES GIVEN BY THE DISPLAY UNIT	34

11. MAINTENANCE	35
■ SYNOPTIC.....	35
■ MAINTENANCE PLAN	36
■ TROUBLESHOOTING.....	37
■ DIAGNOSTICS	38
12. PROPORTION AND OUTPUT ACCORDING TO THE RATIO	39
■ PU 3000 PNEUMATIC, AIRMIX® AND AIRLESS VERSIONS.....	39
■ PU 3000 4 L 30/1, 4 L 53/1 AND 4 L FLOWMAX® 53/1 VERSIONS	40
13. MIXING RATIO	41
14. PNEUMATIC AND ELECTRIC DIAGRAMS	41
15. FEATURES - PU 3000 PNEUMATIC	43
■ COMPOSITION	43
■ TECHNICAL FEATURES	43
■ SPECIFIC PARAMETERS.....	43
16. FEATURES - PU 3000 AIRMIX®	44
■ COMPOSITION	44
■ TECHNICAL FEATURES	44
■ SPECIFIC PARAMETERS.....	44
17. DISASSEMBLY & REASSEMBLY - PU 3000 PNEUMATIC, PU 3000 AIRMIX®	45
■ MIXER.....	45
■ PILOTED VALVES.....	45
CARTRIDGE OF A FLUID VALVE (IND. 9A / 9B / 9C / 9D) (REFER TO DOC. 573.188.050).....	45
■ FLUID SECTION, MODEL C100 (BASE) (REFER TO DOC. 573.080.050).....	47
■ FLUID SECTION, MODEL F100 (CATALYST) (REFER TO DOC. 573.114.050)	49
18. FEATURES - PU 3000 AIRLESS	52
■ COMPOSITION	52
■ TECHNICAL FEATURES	52
■ SPECIFIC PARAMETERS.....	52
19. DISASSEMBLY & REASSEMBLY - PU 3000 AIRLESS	53
■ MIXER.....	53
■ ASI 40 VALVES (REFER TO DOC. 573.062.050)	53
■ FLUID SECTION, MODEL ALTO 50CC (BASE & CATALYST) (REFER TO DOC. 573.395.050)	54
20. FEATURES - PU 3000 4 L 30/1	57
■ COMPOSITION	57
■ TECHNICAL FEATURES	57
■ SPECIFIC PARAMETERS.....	57
21. DISASSEMBLY & REASSEMBLY - PU 3000 4 L 30/1	58
■ MIXER.....	58
■ ASI 40 VALVES (REFER TO DOC. 573.062.050)	58
■ FLUID SECTION, MODEL ALTO 225CC (BASE & CATALYST) (REFER TO DOC. 573.451.050)	59
22. FEATURES - PU 3000 4 L 53/1	62
■ COMPOSITION	62
■ TECHNICAL FEATURES	62
■ SPECIFIC PARAMETERS.....	62
23. DISASSEMBLY & REASSEMBLY - PU 3000 4 L 53/1	63
■ MIXER.....	63
■ ASI 40 VALVES (REFER TO DOC. 573.062.050)	63
■ FLUID SECTION, MODEL MAJOR 227CC # 105 174 01 07 (BASE & CATALYST) (REFER TO DOC. 573.447.050).....	64

24. FEATURES - PU 3000 4 L FLOWMAX® 53/1	68
■ COMPOSITION	68
■ TECHNICAL FEATURES	68
■ SPECIFIC PARAMETERS.....	68
25. DISASSEMBLY & REASSEMBLY - PU 3000 4 L FLOWMAX® 53/1.....	69
■ MIXER.....	69
■ ASI 40 VALVES (REFER TO DOC. 573.062.050)	69
■ FLUID SECTION, MODEL C260 (BASE) (REFER TO DOC. 573.414.050).....	70
■ FLUID SECTION, MODEL F260 (CATALYST) (REFER TO DOC. 573.409.050)	74

ADDITIONAL DOCUMENTATIONS :

Incorporation declaration and EU declaration of conformity	578.013.130
--	-------------

PU 3000 PNEUMATIC

	Spare Parts
PU 3000 Pneumatic Pump - Assembly	Doc. 573.404.050
Pneumatic motor, model 1000 (only for PU3000)	Doc. 573.437.050
BASE fluid section, model C100	Doc. 573.080.050
CATA fluid section, model F100	Doc. 573.114.050
Color changer and valve	Doc. 573.187.050 + Doc. 573.188.050
LP fluid regulator (Spring operated)	Doc. 573.203.110 + Doc. 573.415.050
HP fluid regulator, model 3/8 (260 bar / 3771 psi)	Doc. 573.299.050
Flushing pump, model 02-C85	Doc. 573.457.050

PU 3000 AIRMIX®

	Spare Parts
PU 3000 Airmix Pump - Assembly	Doc. 573.386.050
Pneumatic motor, model 3000	Doc. 573.387.050
BASE fluid section, model C100	Doc. 573.080.050
CATA fluid section, model F100	Doc. 573.114.050
Color changer and valve	Doc. 573.187.050 + Doc. 573.188.050
Filter, model HP 3/8 (260 bar / 3770.8 psi)	Doc. 573.299.050
Flushing pump, model 30-C25	Doc. 573.438.050

PU 3000 AIRLESS

	Spare Parts
PU 3000 Airless Pump - Assembly	Doc. 573.389.050
Pneumatic motor, model 5000	Doc. 573.390.050
BASE & CATA fluid section, model 50cc	Doc. 573.395.050
ASI 40 valve	Doc. 573.062.050
Filter, model HP 3/4 (360 bar / 5222 psi)	Doc. 573.327.050
Flushing pump, model 30-C25	Doc. 573.438.050

PU 3000 4 L 30/1

	Spare Parts
PU 3000 4 L 30/1 PUMP - Assembly	Doc. 573.452.050
Pneumatic motor, model 5000	Doc. 573.390.050
BASE & CATA fluid section, model 225cc	Doc. 573.451.050
ASI 40 valve	Doc. 573.062.050
Filter, model HP 3/4 (360 bar / 5222 psi)	Doc. 573.327.050
Flushing pump, model 30-C25	Doc. 573.438.050

PU 3000 4 L 53/1

	Spare Parts
PU 3000 4 L 53/1 Pump - Assembly	Doc. 573.453.050
Pneumatic motor, model 7000	Doc. 573.450.050
BASE & CATA fluid section, type 227cc	Doc. 573.447.050
ASI 40 valve	Doc. 573.062.050
Filter, model HP 3/4 (360 bar / 5222 psi)	Doc. 573.327.050
Flushing pump, model 30-C25	Doc. 573.438.050

PU 3000 4 L FLOWMAX® 53/1

	Spare Parts
PU 3000 4 L 53/1 FLOWMAX® Pump - Assembly	Doc. 573.461.050
Pneumatic motor, model 7000-F	Doc. 573.458.050
BASE fluid section, model C260	Doc. 573.414.050
CATA fluid section, model F260	Doc. 573.409.050
ASI 40 valve	Doc. 573.062.050
Filter, model HP 3/4 (360 bar / 5222 psi)	Doc. 573.327.050
Flushing pump, model 30-C25	Doc. 573.438.050

DIAGRAMS

Pneumatic and electric diagrams	055.680.031
---------------------------------	-------------

Dear Customer, You are the owner of our new PU 3000 mixing system and we would like to take this opportunity to thank you.

Special care has been taken during all designing and manufacturing process to make sure your investment will provide full satisfaction. Non-compliance with instructions and precautions stated in this manual could reduce the equipment working life, resulting in operating problems and create unsafe conditions.

1. SAFETY INSTRUCTIONS

■ GENERAL SAFETY INSTRUCTIONS



CAUTION : The equipment can be dangerous if you do not follow our instructions concerning installation and servicing described in this manual and in accordance with applicable European standards and local national safety regulations.

Please carefully read all the instruction literature before operating your equipment.

Only trained operators can use the equipment.

The foreman must ensure that the operator has understood the safety instructions for this equipment as well as the instructions in the manuals for the different parts and accessories.

Read carefully all instruction manuals, label markings before operating the equipment.

Incorrect use may result in injury. This equipment is for professional use only. It must be used only for what it has been designed for. Never modify the equipment. The parts and accessories supplied must be regularly inspected. Defective or worn parts must be replaced.

Never exceed the equipment components' maximum working pressure.

Comply with regulations concerning safety, fire risks, electrical regulations in force in the country of final destination of the material. Use only products or solvent compatible with the parts in contact with the material (refer to data sheet of the material manufacturer).



**Refer to 'Installation and safety instructions' document
(doc. 578.001.130-UK).**

■ SPECIFIC SAFETY INSTRUCTIONS



The control box of the PU 3000 mixing machine shall be installed outside the explosive area. It shall be installed in a safe area (non-explosive area according to the ATEX directive - refer § 5).



Do not install the paint drums underneath the pumps or the electric equipments. Place them in front of the frame. Install a cover on the drums to reduce the diffusion of gas and vapours in the booth.



Connect the control box to the mains supply fitted with a ground.

The fluid module is fitted with a ground. Connect the ground cable to earth.

Do not use any product or solvent incompatible with the machine components.

Use the appropriate solvent for the material being sprayed to increase the equipment working life.



Wear protective glasses to protect the operator from possible discharges during the handling of the machine.



CAUTION : To prevent from any formation of gas and inflammable vapours, use paint whose flash point is the highest possible (refer to materials' safety instructions).

Before cleaning or removing components of the equipment, it is compulsory :

- 1 - to shut off the air supply,**
- 2 - to open the gun fluid circuit and depressurize the hoses,**
- 3 - to switch off the machine electrical supply.**

■ ENVIRONMENT

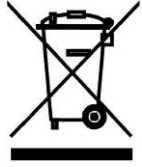

The equipment consists of a label plate with the name of the manufacturer, the equipment part number, the interesting informations to use correctly the equipment (pressure, voltage...) and the above pictogram.

The equipment is designed with and consists of high quality materials and components which can be re-used.

The 2012/19/UE European Directive covers all equipments with a crossed-out bin pictogram. Please inform yourself about the collection systems for electric and electronic equipments.

Please act according to local rules and do not throw the old equipments with household wastes. A correct disposal of the old equipment will help prevent negative consequences for the environment and health.

■ ELECTROSTATIC INSTALLATION

It is better not to use the equipement with water-based paints.

For paints with a resistivity $> 5\text{Mohm}$, we recommend you to consult SAMES KREMLIN in order to integrate properly the unit.

2. DESCRIPTION

The PU 3000 proportioning system is designed for applying two component solvent or water-based paints and lacquers.

There are three versions available :

- a pneumatic version (maximum pressure : 0-6 bar / 0-87 psi or 6-40 bar / 87-580 psi)
- an AIRMIX® version (maximum pressure : 180 bar / 2610 psi),
- an AIRLESS version (maximum pressure : 350 bar / 5076 psi),
- a 4 L 30/1 version (maximum pressure : 180 bar / 2610 psi),
- a 4 L 53/1 version (maximum pressure : 350 bar / 5076 psi),
- a 4 L Flowmax® 53/1 version (maximum pressure : 350 bar / 5076 psi).

It is under an independant form only supplied with compressed air (maximum 6 bar / 87 psi) and an electric supply (115V / 230V).

It consists of :

- a control box with PLC and electromagnetic control components,
- a frame supporting a BASE pump, a CATALYST pump, the automatic valves for the materials and the solvent, and electropneumatic control components.

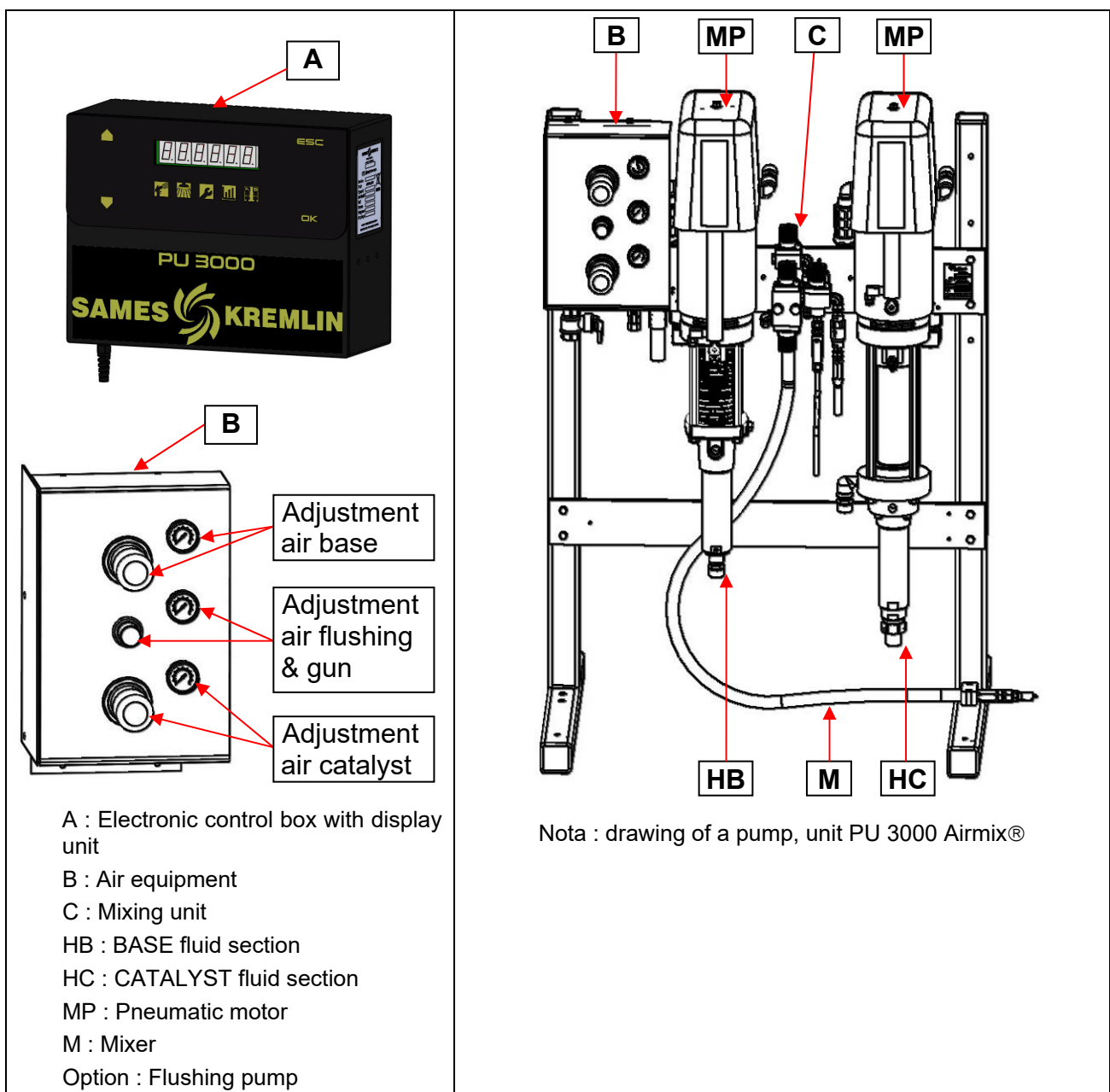

FRONT VIEW OF THE CONTROL BOX

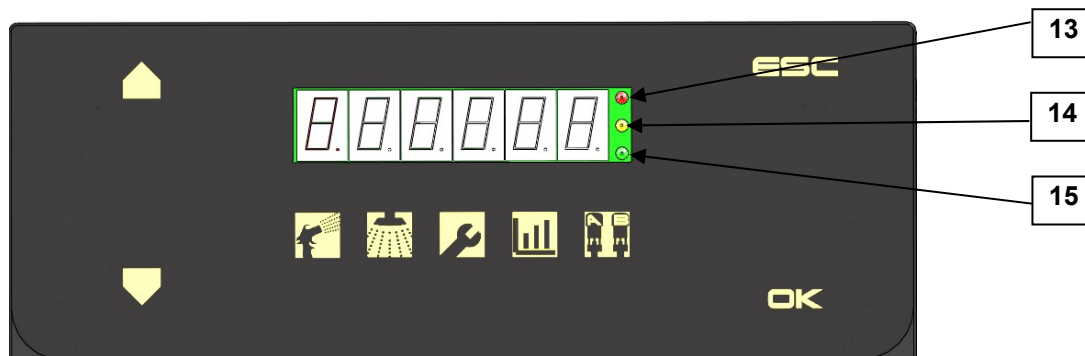

Ind.	Description	Fonction
13	Red LED	Fault
14	Orange LED	Working (other than production)
15	Green LED	Production





The machine is totally programmable via a man/machine interface. The screen indicates continuously, by a simple identification, the status of the machine and it enables the operator to have access to the essential functionalities : ON / OFF - FLUSHING / PRODUCTION.

The information relating to the operating of the machine (real time display of the ratio, of the consumption...) can be read on the LCD screen.

The PU 3000 continuously saves data on the consumptions of base, catalyst and solvent as well as the total consumptions and the emissions of Volatile Organic Compounds (VOC) during the operation of the machine (production mode only).

On the box of the machine, a seal gland enables an electrical supply to the machine with electricity via a safety isolating switch (115V / 230V).

The pictograms located under the screen allow the user to remember easily the various functions managed by the PU 3000.

Pictogram	Mode	
	Production	F 1
	Flushing	F 2
	Parameters	F 3
	Consumptions / Print	F 4
	Feeding of the pumps	F 5

3. OPERATING DESCRIPTION

The 2 BASE and CATALYST materials are sent to the mixing machine from 2 pumps.

In production, as well as in regeneration, the machine injects a small volume of catalyst (P-6) in the base continuous flow.

The PLC continuously checks the mixing ratio and if it notices a fault that it cannot correct, an alarm is activated. The machine goes into safety mode.

The capacity of the pumps is configured (for the BASE pump : P4 parameter, for the CATA pump : P5 parameter) depending upon the equipment versions.

4. FEATURES

<p>Number of colors : 1 Number of catalyst : 1 Solvent and water-based paints compatibility Control via a magnet in the control box Continuous mixing check Adjustable threshold alarm Adjustable pot-life indicator Automatic flushing cycle (time) VOC display Consumptions' total indicator : base, cata, solvent, VOC Printing (connection to a printer or to a computer)</p>	<p>Voltage : 230V / 115V - 10W Air pressure: Mini 4 bar / 58 psi - Maxi 6 bar / 87 psi Dew point = + 3°C / 37°F Filtration 5µm Operating pressure : from 0-6 bar / 0-87 psi or from 6-40 bar / 87-580 psi for the pneumatic version from 30 to 180 bar / from 436 to 2610 psi for the Airmix® version from 60 to 350 bar / from 870 to 5076 psi for the Airless version from 30 to 180 bar / from 436 to 2610 psi for the 4 L 30/1 version from 60 to 350 bar / from 870 to 5076 psi for the 4 L 53/1 version from 60 to 350 bar / from 870 to 5076 psi for the 4 L Flowmax® 53/1 version Adjustable mixing ratio : from 0.6/1 to 20/1 (BASE volume / CATALYST volume) (from 160% to 5%) Mixing precision : ± 1 % Répeatability : ± 1 % Mixed fluid output : refer to § 12 & 13 Maximum operating temperature : 50°C / 122°F</p>
<p>Weight : 115 kg / 253.5 lb (Pneumatic version) 187 kg / 412 lb (Airmix® version) 217 kg / 478.5 lb (Airless version) 170 kg / 375 lb (4 L 30/1 version) 210 kg / 463 lb (4 L 53/1 version) 210 kg / 463 lb (4 L Flowmax® 53/1 version)</p> <p>Dimensions :</p> <ul style="list-style-type: none"> - Control box : 355 mm x 275 mm x 135 mm - Fluid frame : 860 mm x 670 mm x 1280 mm (pneumatic version) 860 mm x 670 mm x 1270 mm (Airmix® version) 960 mm x 670 mm x 1400 mm (Airless version) 960 mm x 670 mm x 1405 mm (4 L 30/1 version) 960 mm x 670 mm x 1435 mm (4 L 53/1 version) 960 mm x 670 mm x 1435 mm (4 L Flowmax® 53/1 version) 	<p>Connections : Air inlet : F 3/4 BSP (air inlet valve) Fluid outlet (mixer) : F 3/4 JIC or assembly of a fitting (→ M 1/2 JIC)</p> <p>OPTION : * Pickit 2 (Electronic programming kit) : the kit allows you to update the program on the electronic cards.</p>

5. INSTALLATION

■ HANDLING

The PU 3000 system with relevant weight and dimensions must be handled by appropriate means.

Nota : The handling of the machine must be carried out by a qualified staff, in an appropriate space, correctly cleared to avoid any risks of fall or of crushing of people.



Nota : The ring located above the cover is for the hoisting of the pump and shall not be used for the handling of the complete machine.

The frame has 4 holes (\varnothing 9) to be fixed on a bracket or on the floor.

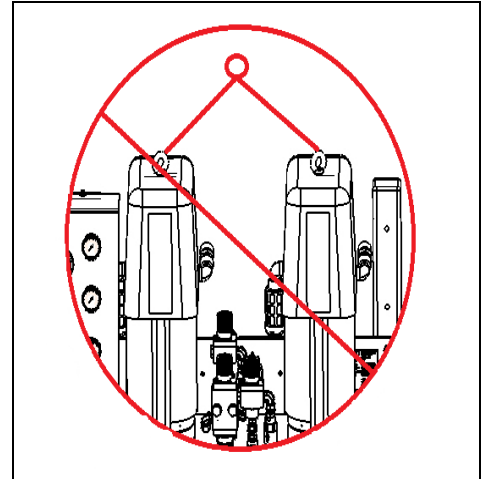

■ STORAGE

Storage before installation :

- Storage ambient temperature : 0 / + 50 °C. / 32 / +122° F
- Protect the equipment against dust, running water, dampness and shocks.

Storage after installation :

- Operating temperature : + 15 / + 35 °C. / + 52 / + 95° F
- Protect the equipment against dust, running water, dampness and shocks.

■ ENVIRONMENT ON THE AREA

The unit must be installed on a horizontal stable floor (eg : flagstone).





Ensure the machine is stable.

The working area must be correctly ventilated.



■ **DESCRIPTION OF THE LABEL MARKINGS**

The PU 3000 machine is fitted with 2 label markings : a plate on the control box and another one on the fluid equipment.



Marking according to the ATEX regulation

<div style="text-align: center;">  <p>STAINS FRANCE GOFFRET PUB000</p> <p>CE  II (2)G [Ex ia] IIA</p> <p>Tension <input style="width: 80px;" type="text"/></p> <p>P air <input style="width: 80px;" type="text"/> 6/87 Bar/Psi </p> <p>P prod <input style="width: 80px;" type="text"/></p> <p>Serie/Serial <input style="width: 80px;" type="text"/> <input style="width: 40px;" type="text"/></p> <p>Ref <input style="width: 80px;" type="text"/></p> <p>Phase <input style="width: 80px;" type="text"/></p> <p>Fréquence <input style="width: 80px;" type="text"/></p> <p>Ampérage <input style="width: 80px;" type="text"/></p> <p style="text-align: center;">NE PAS DEBRANCHER SOUS TENSION DO NOT DISCONNECT WHILE POWER IS ON</p> </div> <p style="text-align: center;">Marking label on the control box (box located <u>outside</u> the spray booth)</p>	<div style="text-align: center;">  <p>STAINS FRANCE</p> <p>PUB000</p> <p>CE  II 2G IIA T3</p> <p>P air <input style="width: 80px;" type="text"/> 6/87 Bar/Psi</p> <p>P prod <input style="width: 80px;" type="text"/></p> <p>Serie/Serial <input style="width: 80px;" type="text"/></p> <p>Ref <input style="width: 80px;" type="text"/></p> <p style="text-align: center;">NE PAS DEBRANCHER SOUS TENSION DO NOT DISCONNECT WHILE POWER IS ON</p> </div> <p style="text-align: center;">Marking label on the fluid module (fluid module assembly can be located inside the spray booth → marking in accordance with the ATEX regulation)</p>
--	--

CONTROL BOX :

SAMES KREMLIN STAINS FRANCE	Name and address of the manufacturer
CE  II (2) G [EEx ia] IIA	CE : European conformity  : For use in explosive area II : group II (2) : Control box contains components ensuring the safety of the class 2 fluid module. G : Gas [EEx ia] : Control box contains SI ia barriers. IIA : Gas group for the equipment category
Tension	PU 3000 voltage
P air	Maximum air pressure
P prod	Maximum fluid pressure
Serie / Serial	Number given by SAMES KREMLIN. The two first numbers indicate the manufacturing year.
Ref	Part number of the PU 3000
Phase	Single phase
Fréquence	50-60Hz / Mains frequency
Ampérage	Maximum current used
NE PAS DEBRANCHER SOUS TENSION DO NOT DISCONNECT WHILE POWER ON	-
	Environmental Indication (refer to § 2 - Environment)

FLUID MODULE :

SAMES KREMLIN STAINS FRANCE	Name and address of the manufacturer
CE  II 2 G IIA T3	CE : European conformity  : For use in explosive area II : group II 2 : class 2 Surface equipment meant to area where explosive atmospheres due to gas, vapours, mists are liable to appear from time to time in usual operating G : gas IIA : Gas group for the equipment category T3 : Maximum surface temperature : 200°C / 392°F
P air	Maximum air pressure
P prod	Maximum fluid pressure
Serie / Serial	Number given by SAMES KREMLIN. The two first numbers indicate the manufacturing year.
Ref	Part number of the PU 3000
NE PAS DEBRANCHER SOUS TENSION DO NOT DISCONNECT WHILE POWER ON	-

■ INSTALLATION DIAGRAM

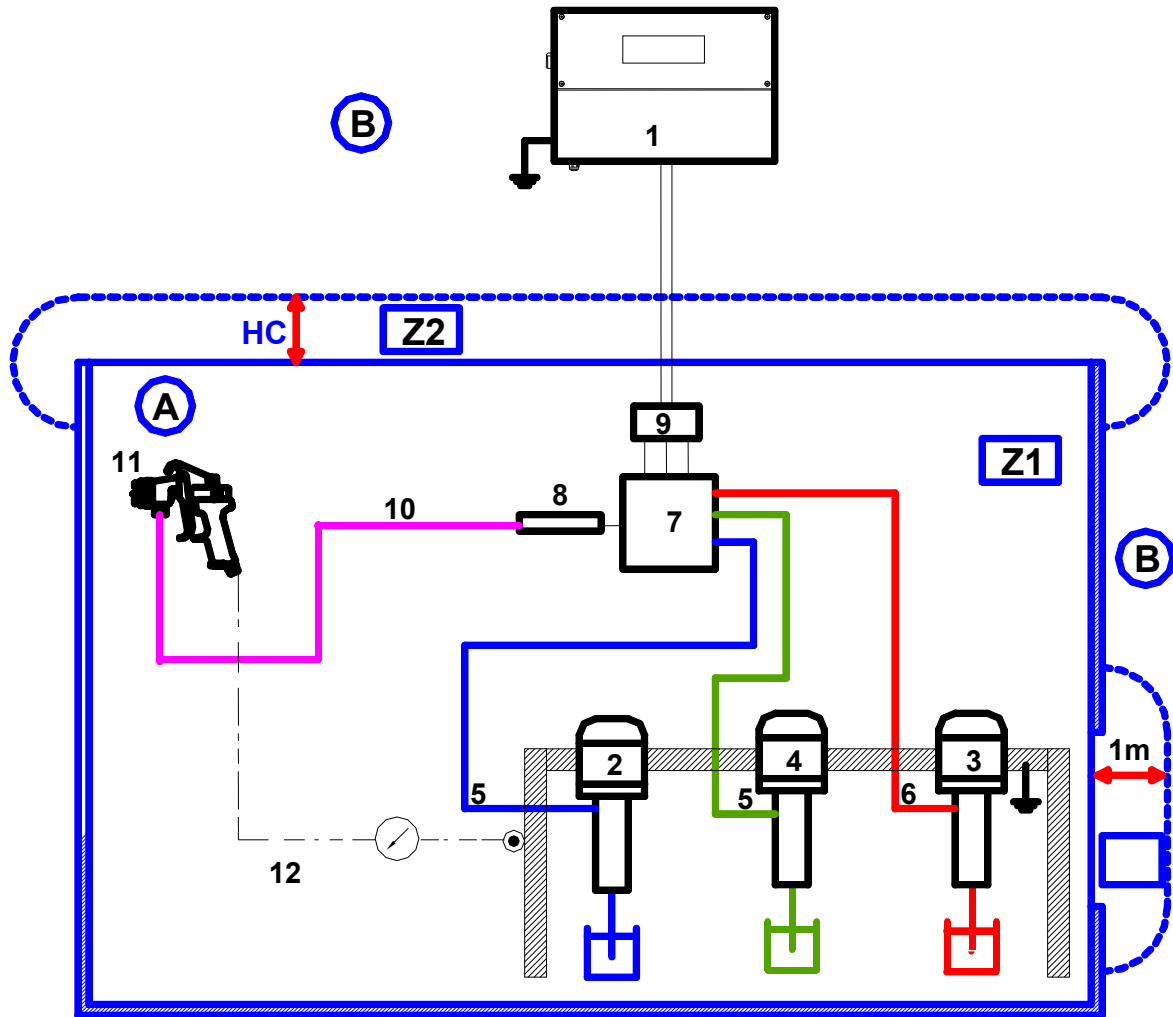

A	Potentially explosive area : area 1 (Z1) or area 2 (Z2) (spray booth)
B	Non explosive area (safe area)
1	PU 3000 control unit
2	BASE pump
3	CATALYST pump
4	Flushing pump (option)
5	HP fluid hose

6	PTFE HP fluid hose
7	Automatic valves
8	Mixer
9	Electrovalves
10	HP Fluid hose (not supplied)
11	Gun (not supplied)
12	Gun spraying air from the machine



The 1 m / 39.37" distance indicated in these diagrams is given for information only and holds harmless SAMES KREMLIN. The user is liable for the exact delimitation of the areas which depends on the material used, the material environment and on the use conditions (refer to EN 60079-10 standard). The 1 m / 39.37" distance could be modified if analysis carried out by the user deems it necessary.



- ➔ The control box must be connected to a supply fitted with a ground. The bracket of the pumps is fitted with a ground cable. That must be grounded.
- ➔ Do not install the paint drums underneath the pumps or the electric equipment. Place them in front of the frame. Install a cover on the drums to reduce the diffusion of gas and vapours in the booth.
- ➔ The electrical cable connecting the chassis mounted electric components to the control box must be installed so that at no time is any risk from mechanical damage, chemical corrosion or excessive heat. Please ensure that the wiring loom is kept separate from any other electrical cables that are not intrinsically safe.

■ INSTALLATION

There are different ways to install the PU 3000 to answer to the majority of the installations.



The control box of the PU 3000 mixing machine must be installed outside the spray booth in a safe area.

Assembly for piloting outside the booth :

The machine is in two parts to enable the control box to be fitted outside the booth (cable of 8 m / 26.2 ft between the 2 elements).

Nota : Drawing of a unit, model PU 3000 Airmix®

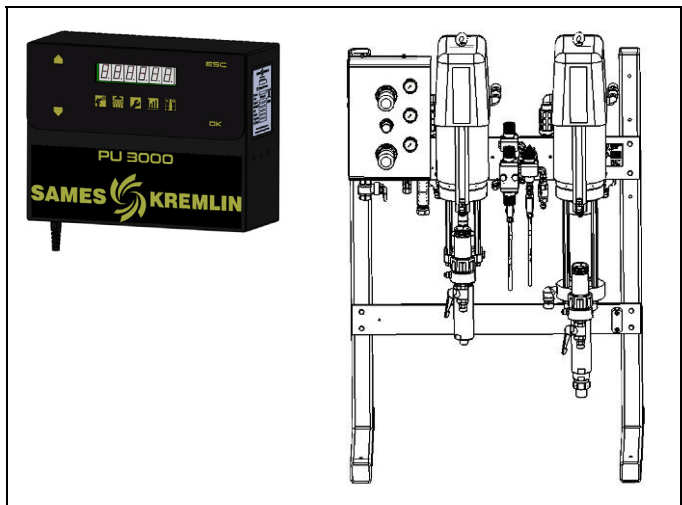

Assembly for machine control in the booth :

There is a booth mounting control kit (available in option).

That kit enables the user to fix the control box on the booth by means of a glass panel and to control the machine inside the spraybooth.

The control is carried out thanks to a magnet provided with the machine. The distance between the control box and the fluid frame is of 8 m / 26.2 ft (cable supplied with the machine).

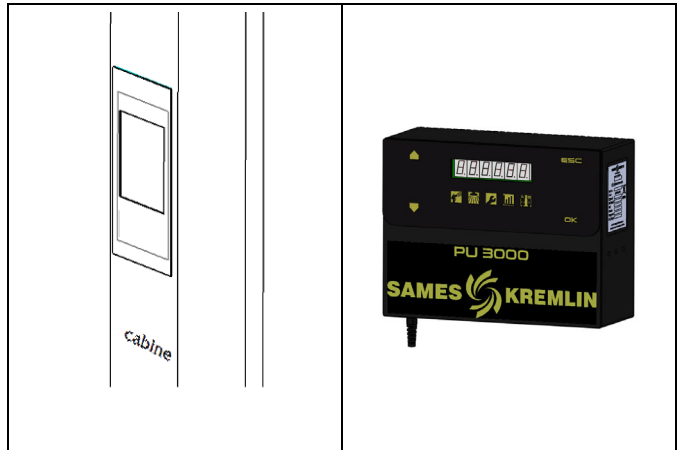

■ CONNECTION OF THE CONTROL BOX AND OF THE FLUID FRAME

➡ The PU 3000 must be connected to a dry and clean compressed air network (minimum 4 bar / 58 psi) and to a single phase electric supply (115V / 230V) connected to an isolating switch. The electric supply must have an appropriate protection (30 mA). The network ground will be connected in the control box on a connect provided



and identified with the symbol

⚠ Before connecting the PU 3000, be certain the mains voltage is the same as the one of the machine (230 V).

If no, open the electric box removing the protective housing and move the jumper (230V → 115V).

The machines with a stabilized electric supply tolerate all voltage types (115V / 230V).

Connect the air equipment of the PU 3000 to the pneumatic network with a conductive hose (minimum 16 mm / 5/8 dia).

Nota : these hoses are not supplied in the standard version.

The air connection of the machine is Female 3/4 BSP (air inlet valve).

The connection between the control box and the electrovalves located on the frame, is carried out via cable, length : 8 m / 26.2".

Between the mixer outlet and the spray gun, you must install a fluid hose, model HP (high pressure) (⚠ act according to the pressures the pumps supply).

**Fuse 160 mA
for machine with serial number < to 09Y1080**

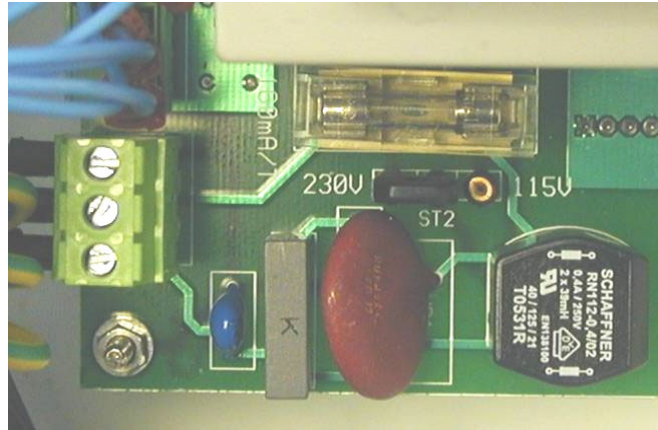

**Fuse 315 mA
for machine with serial number > to 09Y1080**



Machine with a stabilized electric supply

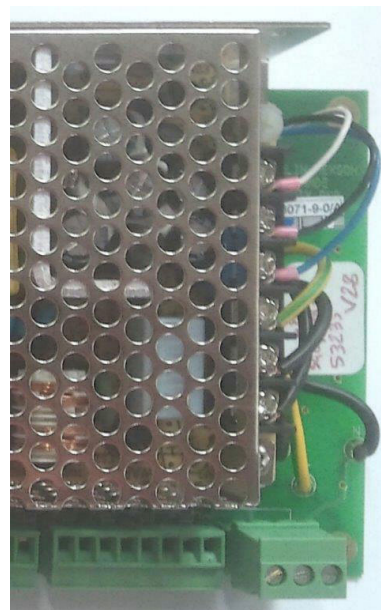

6. OPERATING

■ DRIVING FROM THE MACHINE

SCREEN

Different menus and information relating to the machine are displayed on the alphanumeric screen.

KEYBOARD

ESC	That key enables the user to quit the menus or the different modes (production, flushing, parameters).
OK	That key enables the user to enter in the different menus or to validate a value of parameter.
▲	That key enables the user to shift from a menu to another and to increase the value of a parameter during modifications of value.
▼	That key enables the user to shift from a menu to another and to decrease the value of a parameter during modifications of value.

The keyboard is controlled thanks to a magnet provided with the machine. That control mode enables the user to drive the machine inside the booth if the box is installed behind the booth glass panel. This technology enables the operator to save time and to carry out his work from the place application.

■ SWITCHING ON THE MACHINE



The placing of the system into operation requires that the BASE, CATALYST and SOLVENT drums are full enough to ensure the production.

Connect the gun before placing the system into operation.

Unscrew the 3 air regulators before supplying air to the installation.

Supply air to the PU 3000 (minimum 4 bar / 58 psi).

Switch on the control box (switch located on the side of the box).

When switching on the control box, a menu is displayed on the screen.

Nota : Parameters have been set up in the factory before the delivery of the machine. You must adapt the parameters to the use. They must be modified by an authorized person (refer to list of parameters).

7. FIRST SWITCHING ON

STANDARD MENU

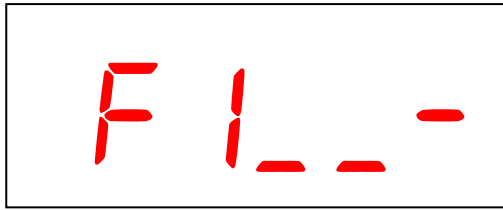

Countdown on fluid life time.
(countdown from 9 to 0; 9 represents 90% of the remaining time before the regeneration).

A line is visible when the PU 3000 is flushed.

When switching on, the machine is waiting. The 'F1' menu corresponds to the shift to the production mode. There are five different menus : they enable to control the PU 3000.

- F1 : production
- F2 : flushing
- F3 : parameters
- F4 : consumptions
- F5 : feeding of the pumps

To surf from a menu to another, you must move placing the magnet on the sensors indicated with '▲/▼'.

The menus scroll as follows :

Arborescence of the menus :

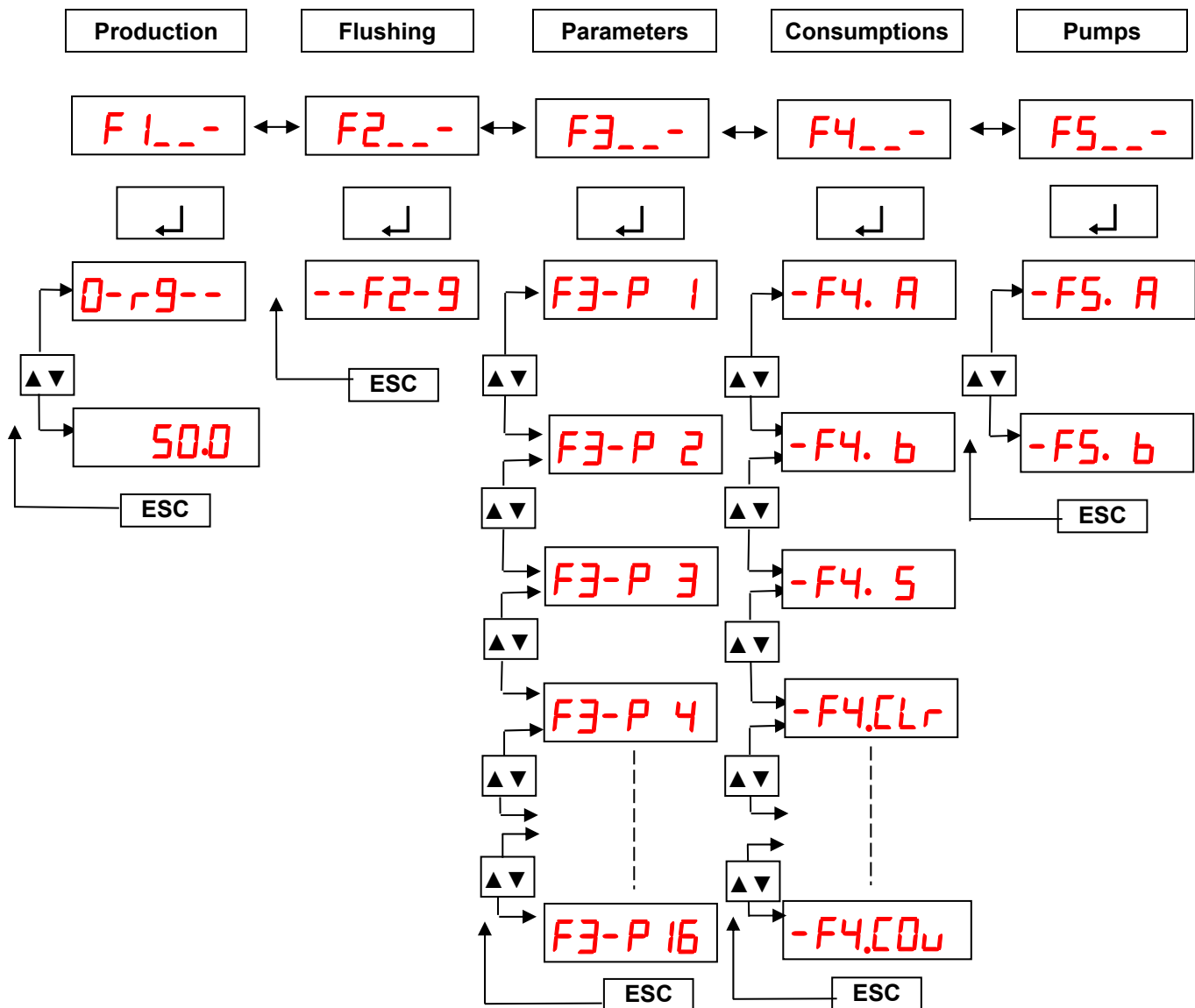

8. FIRST PLACING INTO OPERATION

■ BEFORE SWITCHING ON

Before switching on, half fill the cups with T lubricant or with the appropriate solvent (only for standard fluid sections, not for Flowmax® fluid sections).

Nota : the cup nut must be slightly tightened with the wrench provided. Too much tightening may damage the cup seals.

Tightening of the wetting cup :

- Fill the cup with T lubricant,
- Start the pump, then tighten the cup after 10 minutes, then 1 hour, then 1 day of operating,
- If you notice any leakage, the cup must be tightened.

Nota : Stop the machine and depressurize the air and fluid networks to tighten the cup.

■ FLUSHING OF THE PUMPS AND OF THE MACHINE IN SOLVENT



During that first placing into operation, it is compulsory to have all the pumps into solvent as well as the machine to ensure the good quality of the fluid get by the PU 3000.

The fluid pressure must not exceed 1 bar / 14.5 psi on the gauges.

- Carry out the connections indicated at § 5 (INSTALLATION),
- Immerse the suction rod of the BASE pump in the solvent container,
- Close the gun air supply valve,
- On the page of the display main menu, enter 'NORMAL OPERATING' (F5 then **OK**), then select the A pump (▲ or ▼, and **OK**),
- Trigger the gun to start the A pump with solvent and increase the fluid pressure to at least 1 bar / 14.5 psi (reading on the gauge) or go through the drain valves,
- Release the gun trigger when there are no more air bubbles in the solvent at the gun nozzle,
- Immerse the suction rod of the CATALYST pump in a solvent container,
- On the page of the display main menu, enter 'NORMAL OPERATING' (F5 then **OK**), then select the B pump (▲ or ▼, and **OK**),
- Trigger the gun to start the B pump with solvent and increase the fluid pressure to at least 1 bar / 14.5 psi (reading on the gauge) or go through the drain valve,
- Release the gun trigger when there are no more air bubbles in the solvent at the gun nozzle,
- Turn the air valve that supplies air to the flushing pump,
- On the page of the display main menu, enter 'FLUSHING MODE' (F2 then **OK**),
- Trigger the gun to prime the SA pump with solvent and increase the fluid pressure to at least 1 bar / 14.5 psi (reading on the gauge),
- Release the gun trigger when there are no more air bubbles in the solvent at the gun nozzle,
- Do not modify the factory parameters for the moment.



Caution : Do not supply gun with atomising air to prevent any atomisation and point the solvent fan into a container.

We advise you to wear protective glasses and gloves.

- Go out from the 'NORMAL OPERATING' mode passing to ESC.
- Close the air supply valve of the flushing pump.

■ START UP OF THE MACHINE

- Take off the BASE and CATALYST suction rods from the solvent containers and introduce them in their respective container.

⚠ Caution : never invert the suction rods.

- Open the drain valves located at the outlet of the fluid sections. Start up the pumps. Prime the pumps, then close the drain valves.
- Pass to production mode and let the fluid flow until it flows clean. In case of alarm, disable then go to production mode.

CAUTION : do not supply atomising air to the gun.

- Carry out a flushing to clean the mixed circuit. As soon as the solvent is clean, pass to ESC.

The parameters are preset up in the factory. You can change them (refer to § 9).

■ MIXING RATIO CHECKING

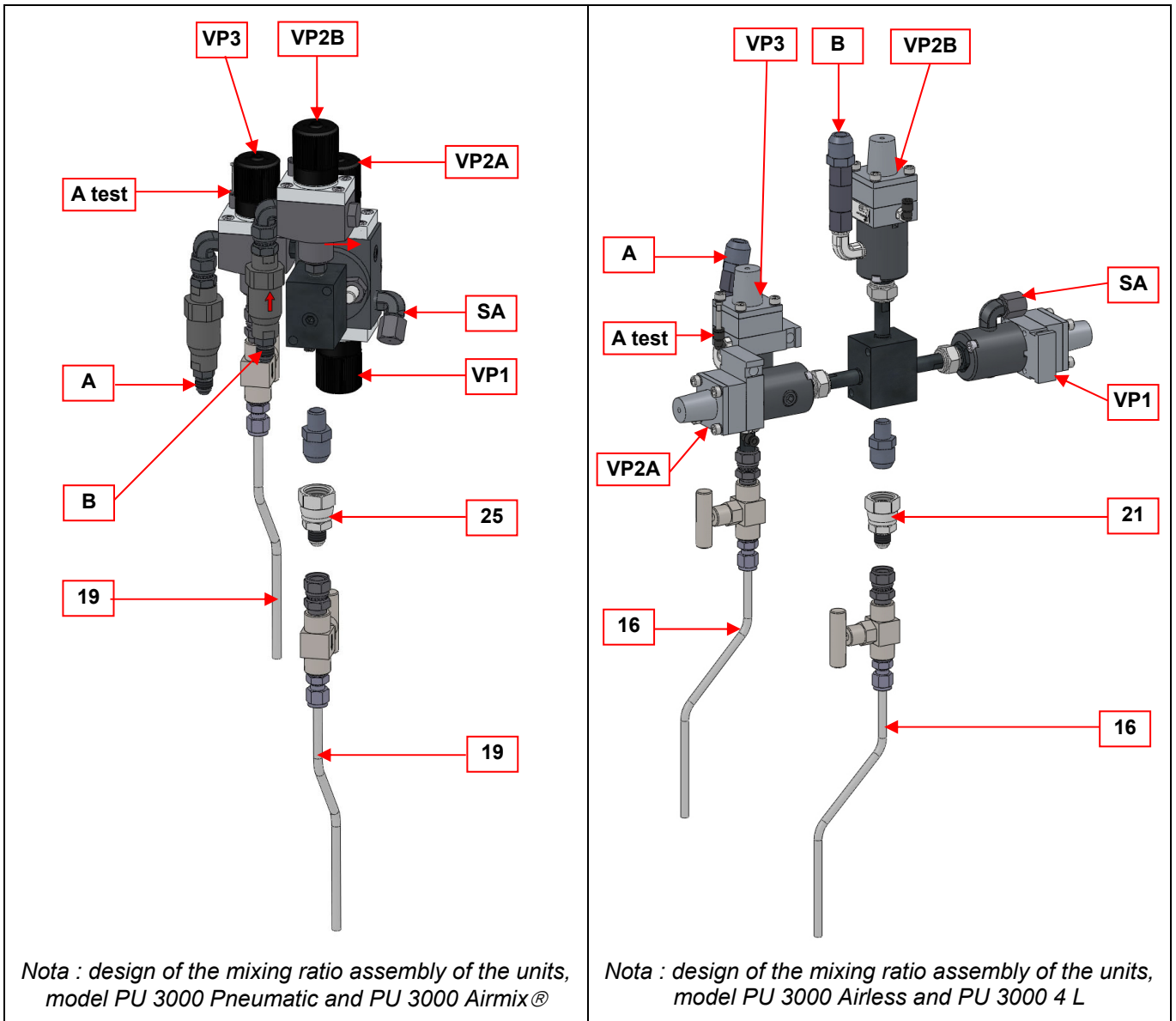

Switch off the unit.

Remove the 'mixed fluid' hose located on the outlet of the mixing unit. Install, instead of it, the fitting (21 or 25) and the needle-valve assembly (16 or 19) supplied with the machine.

Take off the control air hose on the VP2A BASE valve.

Connect that hose to the VP3 valve. The VP3 valve is originally supplied with a needle valve assembly (16 or 19).

Switch on the unit.

Pass in **F 5** mode to adjust the opening of the needle-valves.

-F5 A

Prime the A pump and adjust the opening of the needle-valve.

-F5 b

Prime the B pump and adjust the opening of the needle-valve.

Place the beakers underneath the valves.

Input

-F3 P 16

The PU 3000 passes in test mode and displays

t 500



Caution : the fluid pressure must be lower than 200 bar / 2900.6 psi.

The BASE and CATA materials are dispensed into the beakers. After a while, close the needles' valves and check the ratio.

Activate ESC to stop the test and only after that you can removing the test outlet.

Nota : During that stage, you can not use the spray gun.



When the mixing ratio checking is over, switch off the PU 3000 machine.

Disconnect the air hose from the VP3 valve and connect it to the VP2A BASE valve.

Remove the needle-valve assembly (16 or 19) and the fitting (21 or 25). Screw again the fluid hose on the fitting (M 3/4 JIC) at the outlet of the mixer unit. Start up the machine : enter 'PRODUCTION MODE' (F1 then **OK**).

- ➡ Wear protective glasses to protect the eyes from possible discharges during the handling of the valves.**
- ➡ Flush the needle valve assembly that has been removed and do not leave the catalyst crystallize :**
 - Flush the CATA test outlet : input F2 to carry out the flushing. When it is clean, activate ESC.
 - Flush the BASE test outlet : invert the test outlets and carry out a flushing until it is clean.

9. APPLICATION PROGRAMMING (F3)

To alter the parameters of the PU 3000, go to F3, then validate. To shift from a parameter to another, use the arrows ▲ or ▼.

Select the parameter to alter. Depress the key **OK**, then the arrows ▲ or ▼ to increase or decrease the value. Activate **OK** to validate the new value or ESC to cancel.

To quit a parameter, activate **ESC**.

To quit the PARAMETERS menu, activate **ESC**.

The parameters are pre-set up in the factory. They must be adjusted (by an authorized person) to suit the material to be processed.

 The calibration of the stroke length is carried out in the factory. When removing the movement sensors or when disassembling the fluid section from the motor, it is important to initialize the pumps (refer to Validation of the initialization mode, page 25).

■ PASSWORD

When you start the machine for the first time the access code of the menu 'Parameters' is deactivated, everyone is able to modify the machine's parameters.

To activate this access code you have to :

- enter in the parameter 0 of the menu F3 : F3-- → « key ↵ » → P -- 0 → « key ↵ ».

The code '0000' appears, it's the code present by default in the machine.

- change the code by using the arrows ▲ or ▼ and the «key ↵» for each digit which compose this code.

Once the access code was validated, the access is protected by the password. Only the people who know this password and those which know the administrator code '5555' will be able to reach the menu 'Parameters'.

Each time a user wants to enter in the menu 'Parameters' the password will be required: [0---. The user shall enter the password by using the arrows ▲ or ▼ and the «key ↵» for each digit which compose this code :

- If the entered code is correct, the following fonts ----- appear.

- If the entered code is incorrect, the word 'Error' appears and the machine allows you to enter the password again (Press 'Esc' to return to the principal menu).

If you want to deactivate the password, you just have to parameterise the code '0000' again as access code.

■ PROCEDURE TO GET THE VERSION NUMBER OF THE ELECTRONIC CARD

- Switch off the unit.
- Input **OK**.
- Switch on the control box : the version number is displayed.
- Release **OK** to start the machine out.

■ PARAMETERS

Parameters	Description	Factory adjustment	Your adjustments
F3- -P0	Parameter of the password	0000	
F3- -P1	Mixing ratio parameter. Percentage of catalyst in the base, from 0,1% to 160%	50 %	
F3- -P2	Parameters of the mixed fluid life time Minimum value : 1min Maximum value : 999 min	30 min	
F3- -P3	Regeneration volume parameter in cubic centimetre Minimum value : 1 c.c Maximum value : 9 999 cc	200 cc	
F3- -P4	Section of the A piston Minimum value: 1 mm2 Maximum value : 99 999 mm2	For fluid section - C100 : 465 (airmix® version), 485 (pneumatic version) For fluid section - 50cc : 555 (airless version) For fluid section - 225cc : 1010 (4 L 30/1 version) For fluid section - 227cc : 1025 (4 L 53/1 version) For fluid section - C260 : 1060 (4 L Flowmax® 53/1 version)	
F3- -P5	Section of the B piston Minimum value: 1 mm2 Maximum value : 99 999 mm2	For fluid section - F100 : 470 (airmix® version), 490 (pneumatic version) For fluid section - 50cc : 555 (airless version) For fluid section - 225cc : 1010 (4 L 30/1 version) For fluid section - 227cc : 1025 (4 L 53/1 version) For fluid section - F260 : 1100 (4 L Flowmax® 53/1 version)	
F3- -P6	Injection volume Minimum value : 0,1 cc Maximum value : 999,9 cc	4,8 cc	
F3- -P7	Mixing tolerance Minimum value : 0,1 % Maximum value : 100 %	3 %	
F3- -P8	Alarm volume for the A pump Minimum value : 1 L Maximum value : 40 000 L 0 : parameter not taken into account OK : reset of low level pump shut off –A-	0	

Parameters	Description	Factory adjustment	Your adjustments
F3- -P9	Alarm volume for the B pump Minimum value : 1 L Maximum value : 40 000 L 0 : parameter not taken into account OK : reset of low level pump shut off –B-	0	
F3- -P10	Initialization mode (values of the high and low thresholds of the movement sensors) OK : to activate that mode		
F3- -P11	Flushing time Minimum value : 10 seconds Maximum value : 500 seconds	120 s	
F3- -P12	Flushing volume Minimum value : 10 cc Maximum value : 5000 cc	500 cc	
F3- -P13	Number of thousands of cycles before preventive maintenance on the A pump Minimum value : 1 Maximum value : 9999	500 cyc (i.e. 500 000 cycles)	
F3- -P14	Number of thousands of cycles before preventive maintenance on the B pump Minimum value : 1 Maximum value : 9999	500 cyc (i.e. 500 000 cycles)	
F3- -P15	Percentage of dry extract in the base Minimum value : 0 % Maximum value : 100 %	50 %	
F3- -P16	Ratio Test mode OK : to activate that mode		

■ VALIDATION OF THE INITIALIZATION MODE

That mode enables the machine to define the high and low settings of the movement sensor on each pump.

After validating the F3- -P 10 parameter, the machine displays A1, and controls the down stroke on the BASE pump piston : open the gun or the BASE drain valve to make the piston go down. Once the BASE pump piston is in low position, close immediately the valve or the gun avoid the decompression of the circuit, then input **OK**.

Then, the piston displays A2, it goes up and is waiting for the high setting of the BASE pump. Open the gun or the BASE drain valve to make the piston go up.

Input **OK**.

The machine displays b1, and controls the down stroke of the CATA pump piston : open the gun or the CATA drain valve to make the piston go down.

Once the CATA pump piston is in low point, close immediately the valve or the gun avoid the decompression of the circuit, then input **OK**.

Then, the piston displays b2, it goes up and is waiting for the high setting of the CATA pump : open the gun or the CATA drain valve to make the piston go up. When the piston is up, close immediately the circuit to avoid the decompression.

Input **OK**.

After that last validation, the machine comes back to the parameter F3- -P 10 menu.



Caution : that parameter must be modified only when changing the sensor (disassembly or re-cabling) or when updating the software or or of the electronic card or when changing a barrier Zener (CA and CB only). If the procedure is launched, it must be carried out in entirety, if not : the machine will not work correctly any more.

■ PRODUCTION (F1)



The CATALYST pressure must always be higher by 5 to 10% than the BASE pressure.

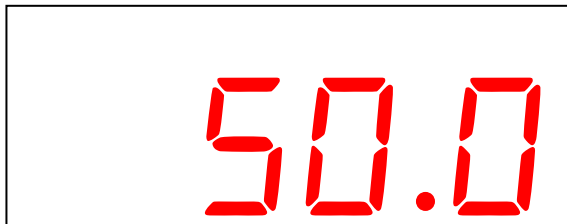

Real mixing ratio

If the machine is in mixed material, open the gun spraying air supply valve.

Trigger the gun.

Adjust the spraying air regulator to get the desired fan.



If the machine is not in mixed material, a regeneration is automatically carried out to bring the mixed material to the gun.

We advise you to shut off air during that stage.

When passing to production for the first time, the machine carries out a regeneration.

0-r9--

The display consists of a countdown that enables to know, in percentage (9 → between 90% and 100% of the volume), the volume remaining to be dispensed according to the P3 parameter. At the end of that stage, the machine enters in production. You can also activate **ESC** during the fluid priming; we advise you not to start painting immediately.

In production, there are 3 main screen messages:

- The operator is spraying and the PU 3000 is operating correctly. The real mixing ratio is displayed on the screen.

500

- The machine stops because of a malfunction. The kind of breakdown is displayed on the screen, the machine emits an alarm signal to inform the operator (cf § 'TROUBLESHOOTINGS').

Err A

Err b

Err 1

Err 4

- The machine has reached the maximum life duration of the material and passes automatically in regeneration mode. The machine emits an alarm signal to inform the operator. The following screen is displayed :

0--9--

Open the gun until the regeneration ends (shut off spraying air), then the machine passes to production.



You can stop the regeneration by activating **ESC**. Then, the regeneration will stop, but be careful, the quality of the mixed material can be inferior.

To exit from production : activate **ESC**.

Nota : We recomend to keep the nozle on the gun during the color priming / regeneration.

■ **FLUSHING (F2)**

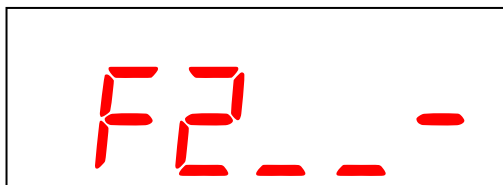

This menu is used for flushing. When you want to flush the machine, activate **OK** when you are on the F2 menu.

After confirming via **OK**, the machine opens the solvent valve. The buzzer sounds intermittently. Check the solvent pump supply valve is open.

A countdown begins : **F2-9**, then **F2-8**.

The machine stops when the countdown is over.

The machine closes the solvent valve and the mixed material flushing has ended.

Nota : Close the spraying air valve during the 'FLUSHING' stage.

During the first flushing, you can determine the solvent volume (F3 P12 parameter) consumed during the flushing time (F3 P11 parameter). Once determined, enter your parameters accordingly.

■ **CONSUMPTIONS / PRINT (F4)**

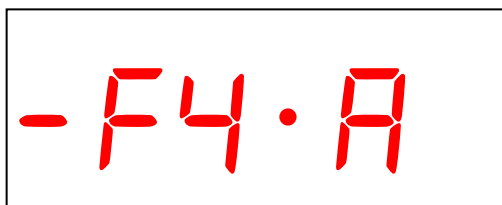

The 'F-4' menu enables to view the consumptions of each material (color, catalyst in L). You can also print the ratio of the consumptions as well as the parameters of the applications : you must connect a connection cable to a printer or to a computer (RS 232 connection) (printer not provided) (refer to Downloading data from PU3000 to a computer page 29).

	Consumption of the base		Consumption of the VOC
	Consumption of the catalyst		Enables the user to reset the consumptions activating the key OK thanks to a sub menu
	Consumption of solvent		Enables the user to print the consumptions and the parameters activating the key OK

Arborescence of the F4.CLR menu :

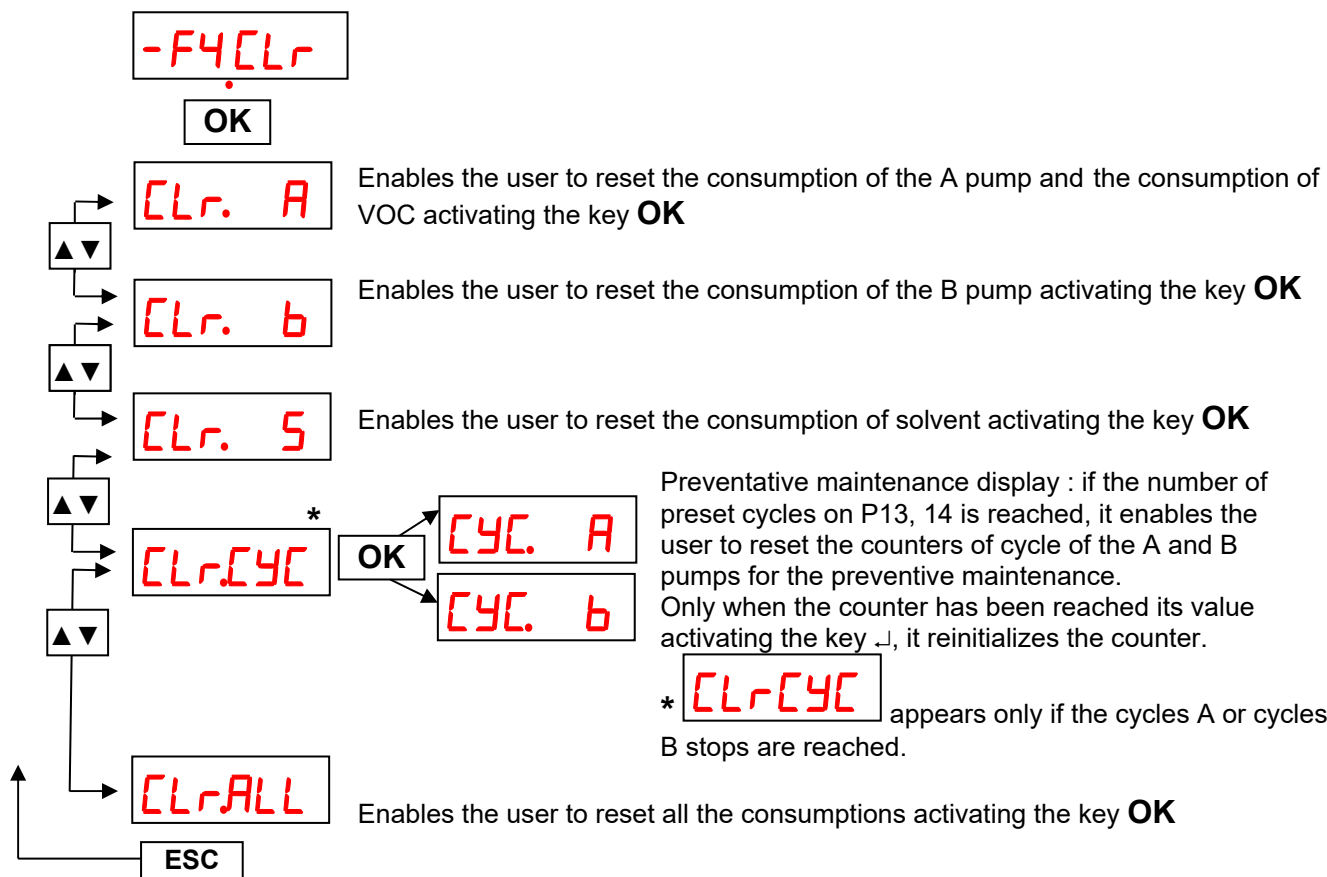

■ DOWNLOADING DATA FROM PU 3000 TO A COMPUTER

Preamble / "Hyper Terminal" issue

This application is necessary. Two cases are to be considered :

- .PC under Windows XP/Vista/2000,
- .PC under Windows 7.

- **With Windows XP/Vista/2000**, "HyperTerminal" application is available with the following path :
Menu Start > All programs > Accessories > Communications > HyperTerminal
- **With Windows7**, you will need to download freeware "HyperTerminal" from some website.

For example :

<http://www.01net.com/telecharger/windows/Bureautique/telephonie/fiches/5829.html>

Once it is downloaded and installed, carry out a simple test of opening and closing.

It should look like this whenever open :

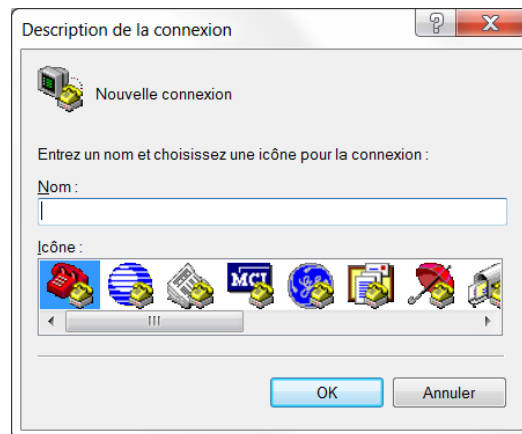

Switching of the control box

- Switch the control box.
- Link a "RS232 male / USB male" cable to the plug located below the Micro back frame, the other end to the USB plugs on the computer. Cable not supplied by KR.



- According to the USB plug used a "port com" number appears in the "device manager" screen (Menu Start > Control panel > Device manager).

- After deployment of the "Ports" line, one of them indicates the cable pilot name ("Prolific USB" for example or else), followed by the "port com" number (COM5 in that display).

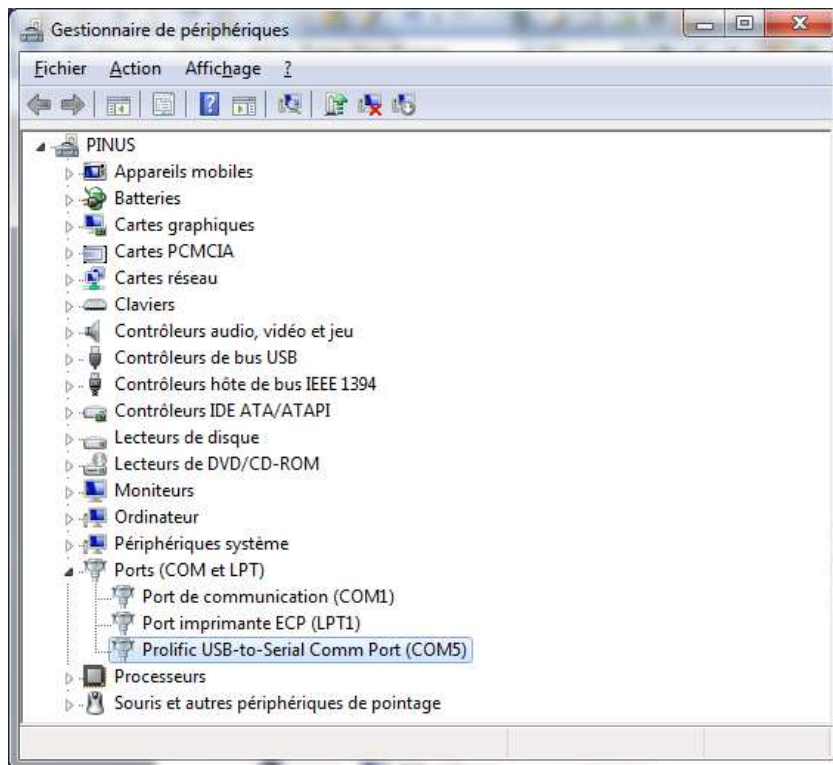

- Open "HyperTerminal" window.
- At the first connection, create a new connecting session, write a name in (order number or paint reference) by choosing the first left icon. Press OK.

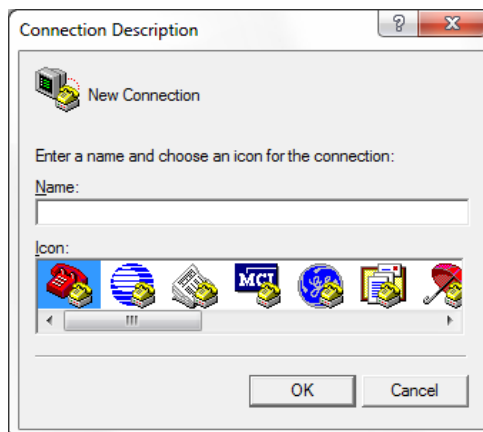

- This screen appears. Select the "port com" number previously noted during your connection. Press OK.

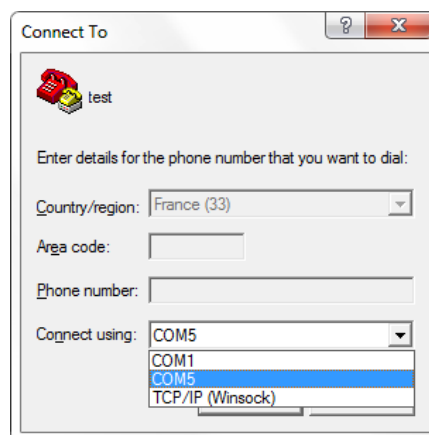

- That new screen will appears. Select band rate 9600 bits/s. Press OK.

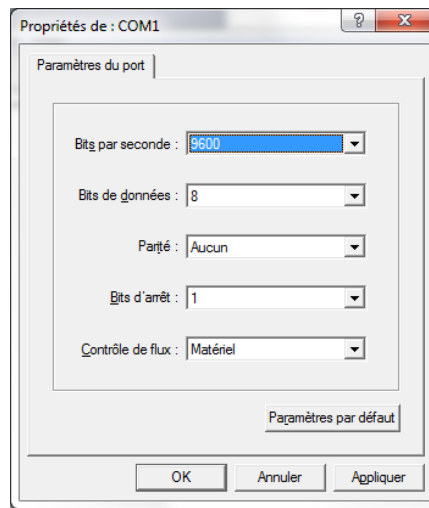

- A connection stopwatch gets activated. Leave the "Hyper Terminal" window open.
- If a session has already been created, opening the existing file is possible by going directly through the "Transfer" menu, and by choosing it within the list of the *.ht files.
(ex : PU3000usb).
- Create a .txt file through "transfer" (transfer > capture text), choose some file name as target (ex : dataPU3000.txt), with a location within the PC disk, and press "START" (the empty file is created / leave the HyperTerminal window always open) :

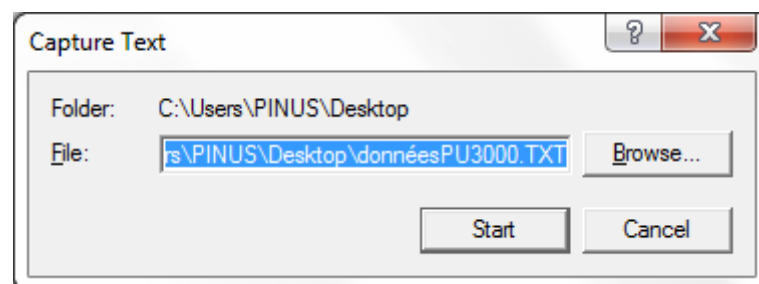
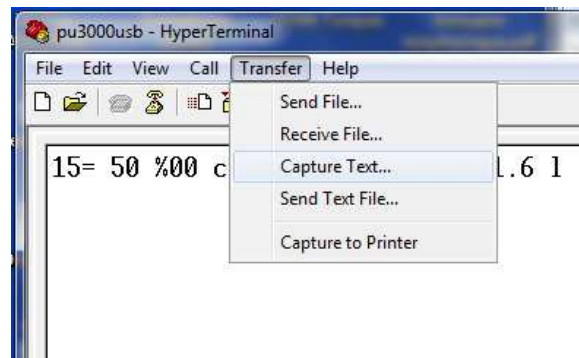

- Launch the data transfer from the control box (menu "F4. Prn" + OK), the data do appear (partially) in the display zone.

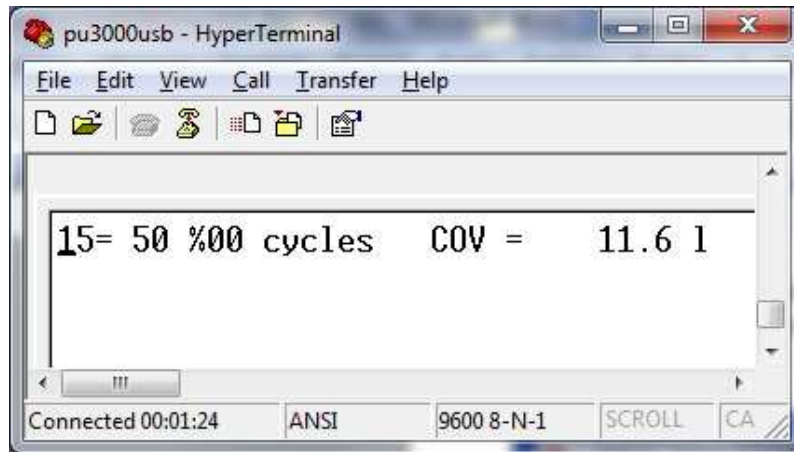

- Get back in the "transfer" menu (transfer > capture text) and press "Stop" :

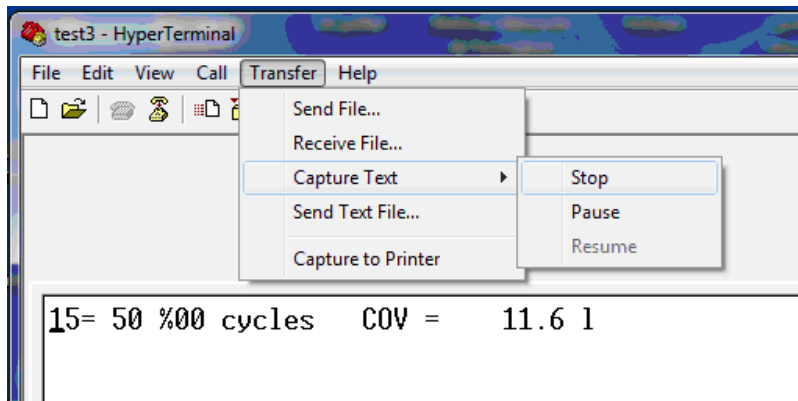

- Data then become available when opening the previous created .txt file.

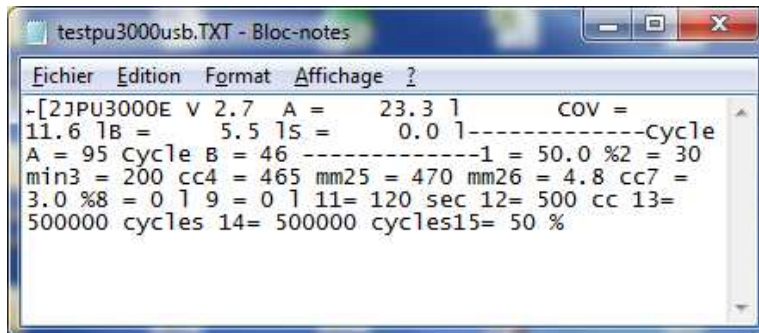

- From these displayed elements .txt (difficult to read up), make a simple "copy/paste" in an Excel file and data will appear as per that screen :

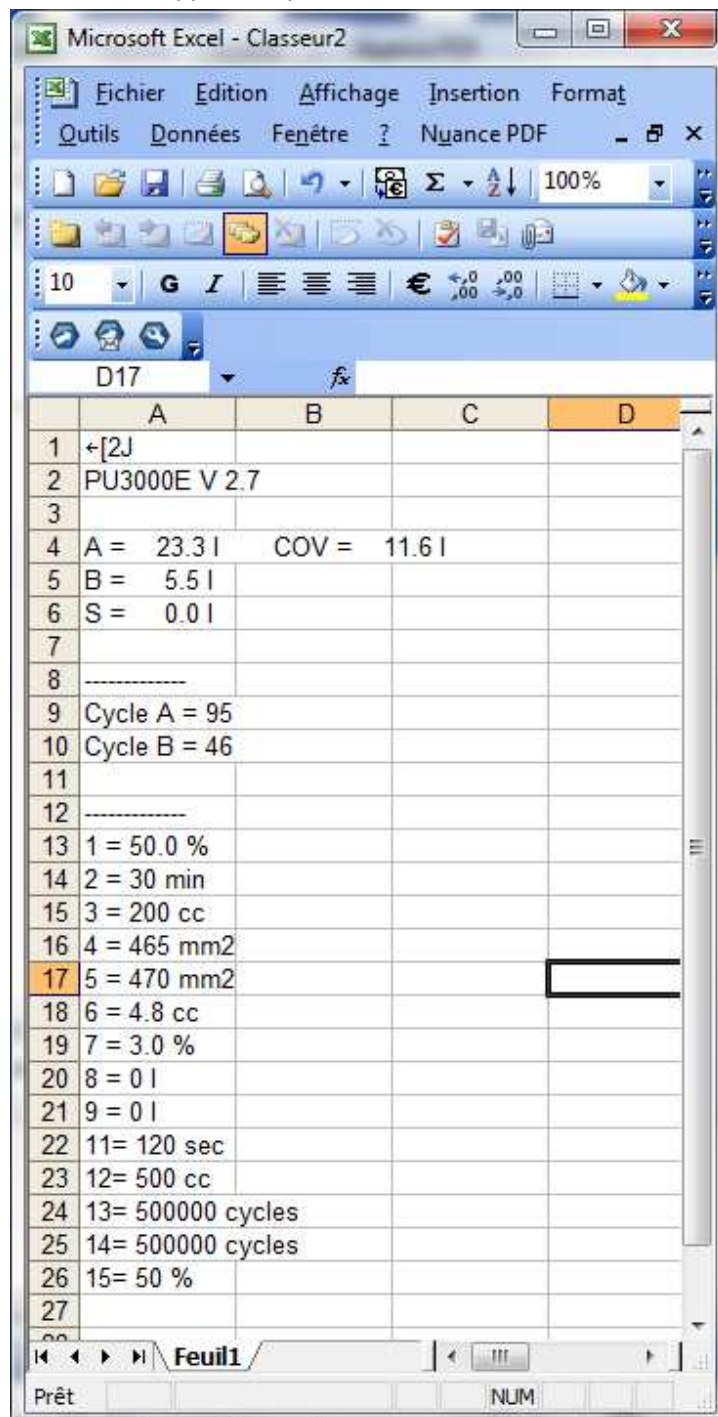

■ DRUM REPLACEMENT PROCEDURE

When replacing the drum, you should prime the pump to avoid air bubbles.

Nota : We recomend you to use a 6 L gravity cup (ref. 151 140 230) to feed the catalyst pump on a gravity mode to avoid air bubbles in the Flowmax pump.

10. INDICATIONS OF OPERATION GIVEN BY THE MACHINE

■ INDICATIONS GIVEN BY THE LEDS

Description	Function	Action
Red LED	Fault	The machine stops
Orange LED	Working	Function other than production (flushing, pot-life alarm ...)
Green LED	Production	
Green + orange LED	Waiting	
LED switched off	Programming	

■ MESSAGES GIVEN BY THE DISPLAY UNIT

The messages given by the display unit are for your information only but do not stop the machine.

Number of cycles' overrun indication

Messages	Indications
Cyc.A	Overrun of the number of cycles configured at the P13 parameter
Cyc.b	Overrun of the number of cycles configured at the P14 parameter
Cyc.Ab	Overrun of the number of cycles configured at the P13 & P14 parameters

Fluids' consumption alarm

Messages	Indications
--A--	<p>A fluid consumption alarm → A container empty (volume fixed by the P8 parameter)</p> <p>OK (during at least 3 seconds) : reset of low level pump shut off –A-</p> <p>This message is displayed in production. Press OK for 3 seconds : the message disappears. The end of drum sensor resets to 0.</p>
--b--	<p>B fluid consumption alarm → B container empty (volume fixed by the P9 parameter)</p> <p>OK (during at least 3 seconds) : reset of low level pump shut off –B-</p> <p>This message is displayed in production. Press OK for 3 seconds : the message disappears. The end of drum sensor resets to 0.</p>

11. MAINTENANCE



Never leave mixed material in the machine. Properly adjust the potlife parameter to avoid curing. Carry out a flushing when the work is over. Flush when ending the work.

■ SYNOPTIC

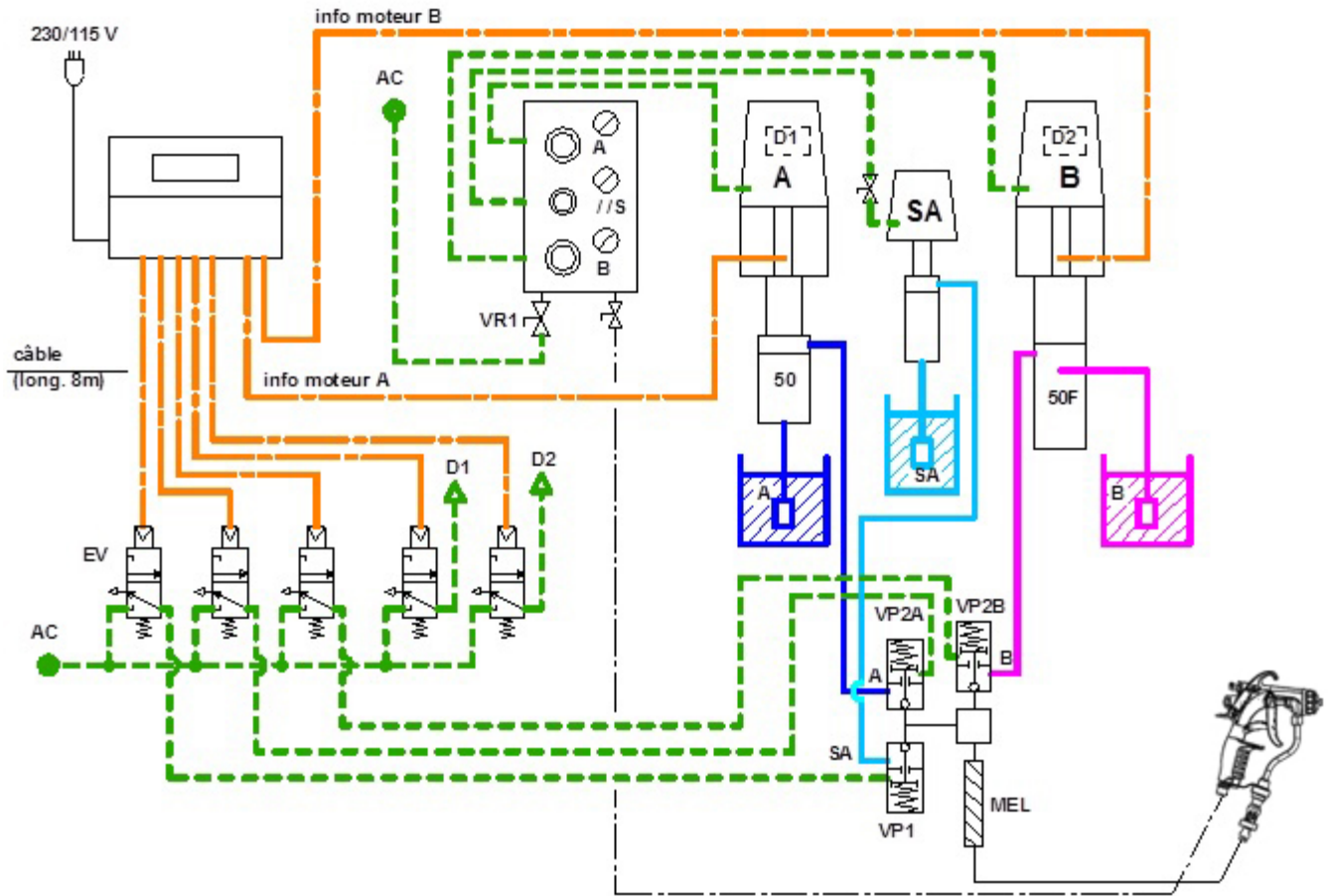

Nota : diagram of a unit, model PU 3000 Airmix®

■ MAINTENANCE PLAN

The life duration of the different elements depends on the properties of the material used. The following maintenance plan is for information only and can not be taken into account when making a complaint.

SUBSET	ELEMENT	OPERATION TO CARRY OUT	TIME EXPECTED	PERIODICITY	MACHINE STATE	TOOLS
Mixer	Mixer	Remove and install a new mixer	2 mn	1 year	stop	
BASE pump	BASE fluid section	Check the lubricant into the cup : its level (1/2 cup) and its colour (colourless)	2 mn	week	stop	T lubricant
		If the lubricant is contaminated, tighten the wetting cup on the upper packing (or change the seals of the packing, if necessary) ; do that with a depressurized pump	10 mn	month	stop	Wrench supplied
		Remove and clean the parts; change the seals and reinstall.	3 h	1 year	stop	
CATALYST pump	CATA fluid section, model standard	Check the lubricant into the cup : its level (1/2 cup) and its colour (colourless)	2 mn	week	stop	P lubricant
		If the lubricant is contaminated, tighten the wetting cup on the upper packing (or change the seals of the packing, if necessary) ; do that with a depressurized pump	10 mn	month	stop	Wrench supplied
		Remove and clean the parts; change the seals and reinstall.	3 h	1 year	stop	
	CATA fluid section, model Flowmax	Remove and clean the parts; change the seals and reinstall	4 h	1 year	stop	
Flushing pump	Fluid section	Check the lubricant into the cup : its level (1/2 cup) and its colour (colourless)	2 mn	week	stop	T lubricant
		If the lubricant is contaminated, tighten the wetting cup on the upper packing (or change the seals of the packing, if necessary); do that with a depressurized pump	10 mn	month	stop	Wrench supplied
		Remove and clean the parts; change the seals and reinstall	2 h	1 year	stop	
Piloted valve	Piloted valve	Remove and change the cartridge	10 mn	1 year	stop	
		Change the piston packing	10 mn	1 year	stop	
Color changer	Piloted valve	Remove and change the cartridge	10 mn	1 year	stop	
		Change the piston packing	10 mn	1 year	stop	

■ TROUBLESHOOTING



For any intervention on the machine :

- Flush the circuits,
- Shut off the compressed air,
- Depressurize the hoses by triggering the gun,
- Shut off the electric supply.

If a problem occurs during the machine operation, alarms will be displayed on the screen of the machine.

Input **OK** to disable each alarm.

TROUBLES	CAUSES	SOLUTIONS
<div style="border: 1px solid black; padding: 5px; display: inline-block;">Err A</div>	Trouble on the BASE fluid section	Check the BASE circuit : - material in the drum, - suction rod strainer, - pump valves. Clean or change. Check the CATALYST pressure towards the BASE pressure.
<div style="border: 1px solid black; padding: 5px; display: inline-block;">Err b</div>	Trouble on the CATALYST fluid section	Check the CATALYST circuit : - material in the drum, - suction rod strainer, - pump valves. Clean or change. Check the CATALYST pressure towards the BASE pressure.
<div style="border: 1px solid black; padding: 5px; display: inline-block;">Err 1</div>	Incorrect mixing ratio Flow incorrectly adjusted	Check the material levels in the supply drums. Check the starting of the pumps. Check the CATALYST pressure towards the BASE pressure.
<div style="border: 1px solid black; padding: 5px; display: inline-block;">Err 4</div>	Irrelevant data capture between the ratio and the injection volume (Machine unable to give the parameters requested)	Check that the P1 parameter (ratio) and the P6 parameter (injection volume) are compatible in injection capability terms in relation to the ratio requested (refer to § 12).

■ **DIAGNOSTICS**

ELECTRIC

FAULTS	CHECKINGS
The machine does not switch on	Check that the isolating switch is on 'I'.
	Check that the mains supply is connected. No : connect it.
	Check that the fuse on the electric card inside the box is in working order. No : change the fuse.
	Check the electric wiring of the supply cable (bad contact or other)

MATERIAL

FAULTS	CHECKINGS
No fluid flows when passing into production or flushing mode.	Check if the valves are open : No : - Check air supply (minimum 4 bar / 58 psi), - Check the connection of the 25 pts cable, - Check the correct operating of the electrovalves. Yes : - Check the fluid pressure, - Check the static mixer.
The machine displays the correct mixing but the consumption of catalyst is too important.	Check the grounds of the machine (230V intake and ground cable of the fluid module)
The machine displays the correct mixing but the consumption of catalyst is not enough.	Check the grounds of the machine.
When the main menu page is displayed, fluid flows out when the gun is open.	Check the valves Checking of the valve : look at what is flowing -if it is solvent, change the valve (VP1) -if it is base, change the valve (VP2A) -if it is catalyst, change the valve (VP2B)

12. PROPORTION AND OUTPUT ACCORDING TO THE RATIO

■ PU 3000 PNEUMATIC, AIRMIX® AND AIRLESS VERSIONS

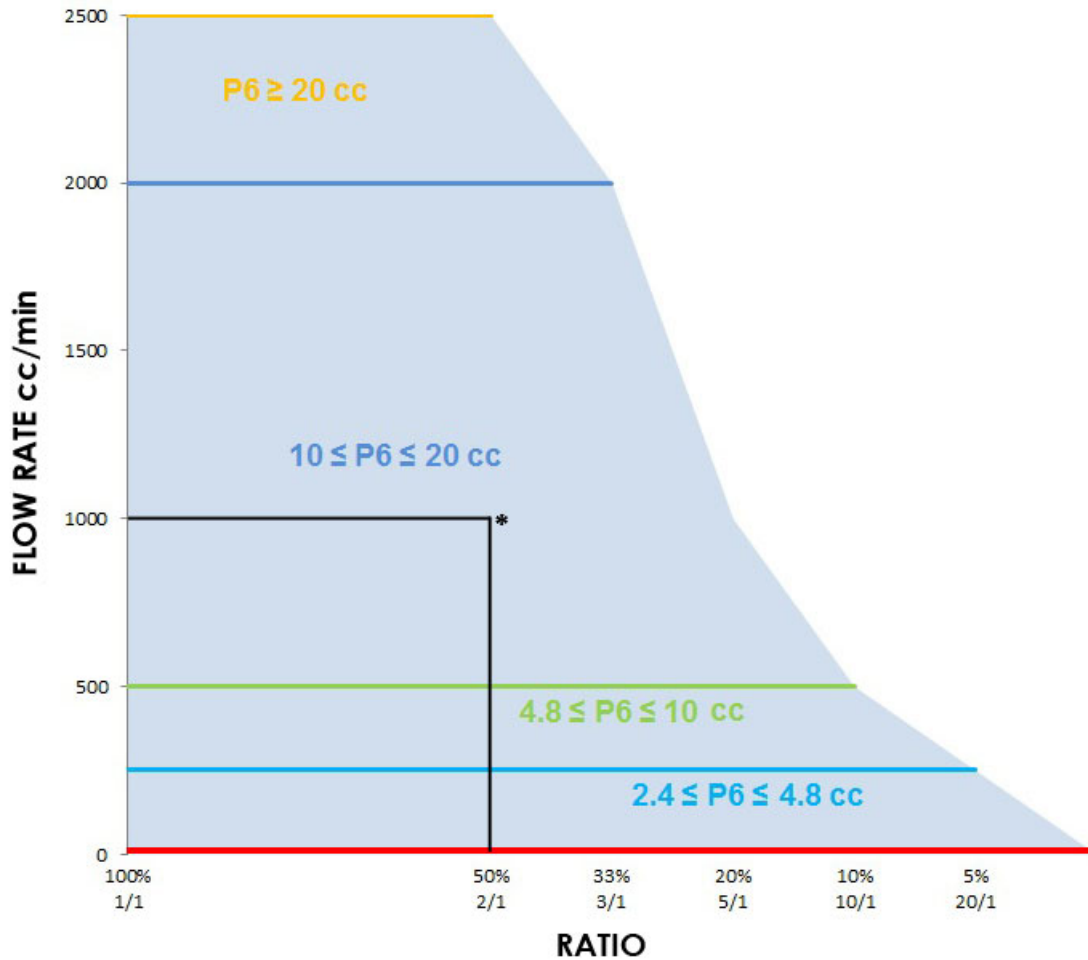

 Operating area of the PU 3000 pneumatic, Airmix® and Airless

* Example :

If you want to get a flow rate of 1000cc/min with a proportion of 2/1 (50%), then the P6 parameter (injection volume of the catalyst) must be adjust between 10 and 20cc.

Nota :

- Tests carried out with same fluid viscosity materials.

The adjustments of pressure and of injection value depend upon the fluid viscosity of the used material.

- The P6 parameter impacts the mixture, you should confirm this parameter by using the mixture on the part you want to paint.

■ PU 3000 4 L 30/1, 4 L 53/1 AND 4 L FLOWMAX® 53/1 VERSIONS

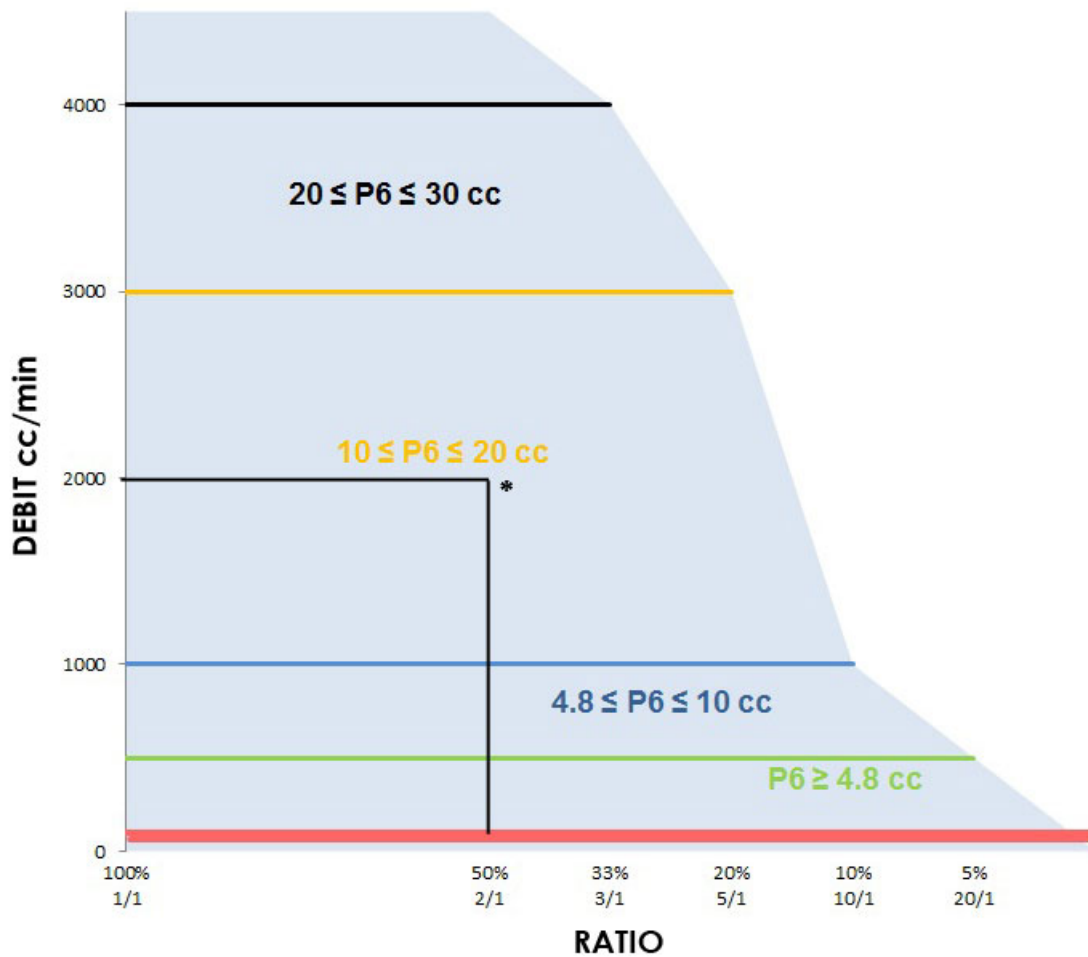

 Operating area of the PU 3000 4 L 30/1, 4 L 53/1 and 4 L Flowmax® 53/1

* Example :

If you want to get a flow rate of 2000cc/min with a proportion of 2/1 (50%), then the P6 parameter (injection volume of the catalyst) must be adjust between 10 and 20cc.

Nota :

- Tests carried out with same fluid viscosity materials.

The adjustments of pressure and of injection value depend upon the fluid viscosity of the used material.

- The P6 parameter impacts the mixture, you should confirm this parameter by using the mixture on the part you want to paint.

13. MIXING RATIO

A : Base B : Catalyst B / A x 100 = X%

Ex : A = 2.5 B = 1 ⇒ 1 / 2.5 x 100 = 40%

A	B	%
0.625	1	160
1	1	100
1.5	1	66.7
2	1	50
2.5	1	40
3	1	33.3
3.5	1	28.6
4	1	25
4.5	1	22.2
5	1	20
5.5	1	18.2
6	1	16.7
6.5	1	15.4
7	1	14.3
7.5	1	13.3
8	1	12.5
8.5	1	11.8
9	1	11.1
9.5	1	10.5
10	1	10

A	B	%
10.5	1	9.524
11	1	9.091
11.5	1	8.696
12	1	8.333
12.5	1	8
13	1	7.692
13.5	1	7.407
14	1	7.143
14.5	1	6.897
15	1	6.667
15.5	1	6.452
16	1	6.25
16.5	1	6.061
17	1	5.882
17.5	1	5.714
18	1	5.556
18.5	1	5.405
19	1	5.263
19.5	1	5.128
20	1	5

14. PNEUMATIC AND ELECTRIC DIAGRAMS

Refer to appendices (Doc. # 055.680.031)

SPECIFICATIONS

PU 3000 PUMP

- model Pneumatic & model Airmix®

15. FEATURES - PU 3000 PNEUMATIC

■ COMPOSITION

BASE pump	Motor :	1000 (only for PU 3000)
	Fluid section :	C100 (standard)
CATALYST pump	Motor :	1000 (only for PU 3000)
	Fluid section :	F100 (Flowmax)
Flushing pump	Option :	Flushing pump, model 02-C85

■ TECHNICAL FEATURES

Maximum air supply pressure	6 bar / 87 psi
Maximum fluid outlet pressure of the PU 3000	0-6 bar / 0-87 psi or 6-40 bar / 87-580 psi
Proportioning ratio / Fluid flow rate	Refer to charts (§ 12 & 13)
Electrical supply of the supply unit	115V / 230V - 10W
Air inlet connection	F 3/4 BSP (air inlet valve)
Fluid outlet connection (mixer)	F 3/4 JIC



The control box of the PU 3000 mixing machine must be installed outside the spray booth.

■ SPECIFIC PARAMETERS

Parameters	Description	Factory adjustment	Your adjustments
F3- -P4	Section of the A piston Minimum value: 1 mm ² Maximum value : 99 999 mm ²	485 (for fluid section, model C100)	
F3- -P5	Section of the B piston Minimum value: 1 mm ² Maximum value : 99 999 mm ²	490 (for fluid section, model F100)	

16. FEATURES - PU 3000 AIRMIX®

■ COMPOSITION

BASE pump	Motor :	3000 (only for PU 3000)
	Fluid section :	C100 (standard)
CATALYST pump	Motor :	3000 (only for PU 3000)
	Fluid section :	F100 (Flowmax)
Flushing pump	Option :	Flushing pump, model 30-C25

■ TECHNICAL FEATURES

Maximum air supply pressure	6 bar / 87 psi
Maximum fluid outlet pressure of the PU 3000	180 bar / 2610.5 psi
Proportioning ratio / Fluid flow rate	Refer to charts (§ 12 & 13)
Electrical supply of the supply unit	115V / 230V - 10W
Air inlet connection	F 3/4 BSP (air inlet valve)
Fluid outlet connection (mixer)	F 3/4 JIC



The control box of the PU 3000 mixing machine must be installed outside the spray booth.

■ SPECIFIC PARAMETERS

Parameters	Description	Factory adjustment	Your adjustments
F3- -P4	Section of the A piston Minimum value: 1 mm ² Maximum value : 99 999 mm ²	465 (for fluid section, model C100)	
F3- -P5	Section of the B piston Minimum value: 1 mm ² Maximum value : 99 999 mm ²	470 (for fluid section, model F100)	

17. DISASSEMBLY & REASSEMBLY - PU 3000 PNEUMATIC, PU 3000 AIRMIX®



CAUTION : Before any work is carried on the pump, stop the machine after carrying out flushing, shut off the compressed air supply and depressurize the circuits triggering the gun.

The pump is manufactured under the ATEX agreement and can not be modified. SAMES KREMLIN will not be held responsible for any failure to comply with that instruction.

■ MIXER

Unscrew the mixer assembly and replace it with a new one.

■ PILOTED VALVES

CARTRIDGE OF A FLUID VALVE (IND. 9A / 9B / 9C / 9D) (REFER TO DOC. 573.188.050)

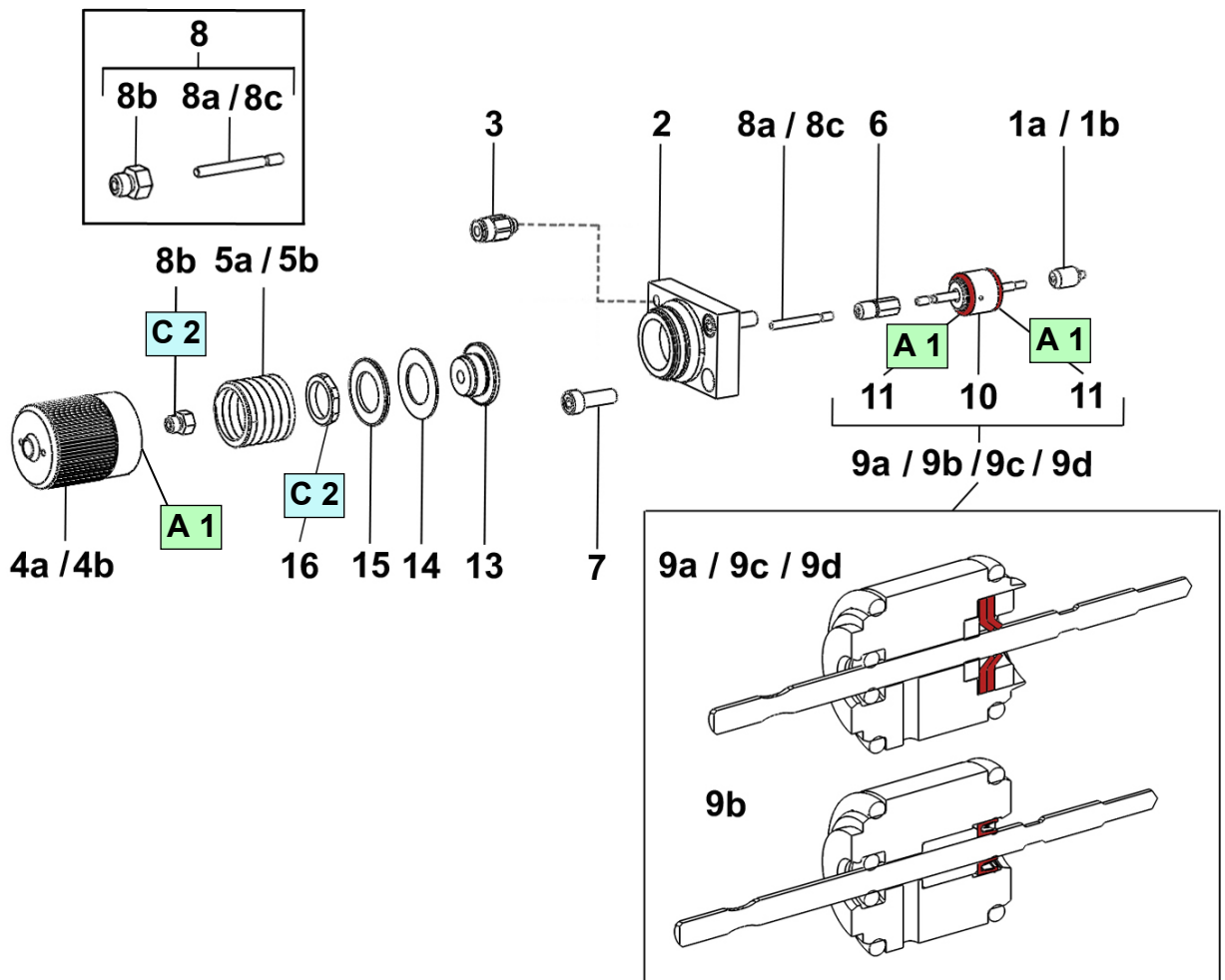

Unscrew the 3 screws (7).

Extract the valve from the module body.

Unscrew the needle (1a / 1b).

Unscrew the cylinder (4a / 4b).

Hold rod carrier (6), unscrew the needle rod and remove cartridge with rod assembly (9a / 9b / 9c / 9d). Remove the seals.

When reassembling :

Change the seals (11), lubricate them then install new cartridge (9a / 9b / 9c / 9d) in cylinder support (2) by pushing it until the cartridge shoulder comes to lean against the cylinder support shoulder. Then reinstall all the components in the reverse order of disassembly.

Install the valve in front of the module body.

Centre the cartridge (9a / 9b / 9c / 9d) on the module body and reinstall screws (7).

PISTON PACKING (Ind. 14)

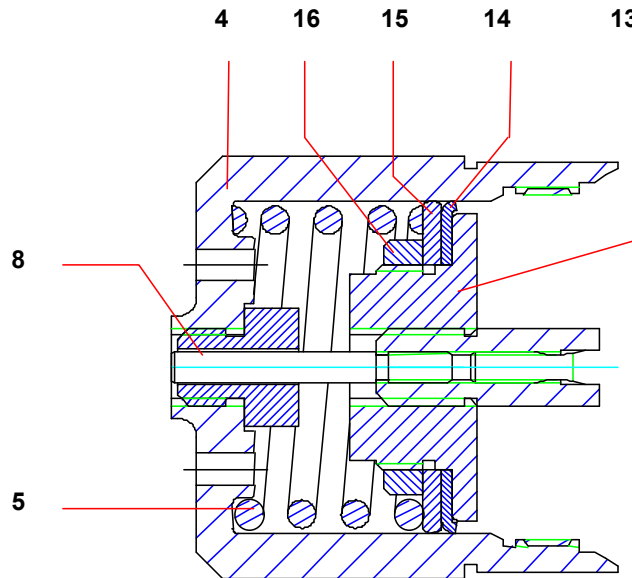

Unscrew the cylinder (4).

Remove the spring (5).

Unscrew the opening signal light (8).

Unscrew the nut (16).

Remove the support washer (15) and the packing (14).

Clean the parts and change them if necessary.

Before reassembling :

Before assembling on the piston (13), take care of shaping the cartridge lip (14) by hand as shown in the above drawing (cartridge turned up on the piston).

The nut (16) must be glued on the piston (13) with loctite adhesive (eg : Loctite 222).

Index	Instructions	Description	Part number
A 1	PTFE grease	'TECHNILUB' grease (10 ml / 0.34 oz)	560.440.101
C 2	Low strength - Anaerobic Adhesive	Loctite 222 (50 ml / 1.7 oz)	554.180.010

Guards (air motor cover, coupling shields, housings ...) have been designed for safe use of the equipment.
The manufacturer will not be held responsible for bodily injury or failure and / or damage to property due to removal or partial removal of the guards.

SUCTION VALVE

Unscrew suction valve (5) by holding cylinder (2).

The ball (10a / 10b) is secured on the valve (5) by means of a circlips (9).

Clean the parts.

Reinstall suction valve (5) and seal (25). Replace them if necessary.

EXHAUST VALVE AND MOBILE PACKING

Unscrew cylinder (2) and pull it downwards.

Unscrew exhaust valve (6) by holding piston (3).

Remove ball (17a / 17b), washer (12a / 12b) and seal (13a / 13b / 13c).

Clean the parts.

Remount the parts in reverse order.

For that :

- Install seal (13a / 13b / 13c), washer (12a / 12b) and ball (17a / 17b) onto exhaust valve (6).
- Screw exhaust valve (6) into the piston (3). The seal must be blocked by screwing exhaust valve (6) strongly.

If necessary replace seal (8) when reinstalling cylinder (2).

UPPER PACKING

Separate motor piston rod from hydraulic piston (3).

Unscrew wetting-cup (4) by means of the wrench supplied with the pump.

Pull piston (3) upwards to remove upper packing seals (21 and 22a / 22b) or the upper packing (18a / 18b).

Reinstall parts in reverse order. Be certain seals (21 and 22a / 22b) or upper packing (18a / 18b) are installed properly (direction, order and assembly dimension).

Tighten wetting-cup (4).

After reassembly, fill up the pump with solvent and increase pressure to maximum in the fluid section. Then stop the pump and open exhaust valve to depressurize.

Retighten wetting-cup (4) by means of the wrench in order to be in accordance with the opposite drawing.

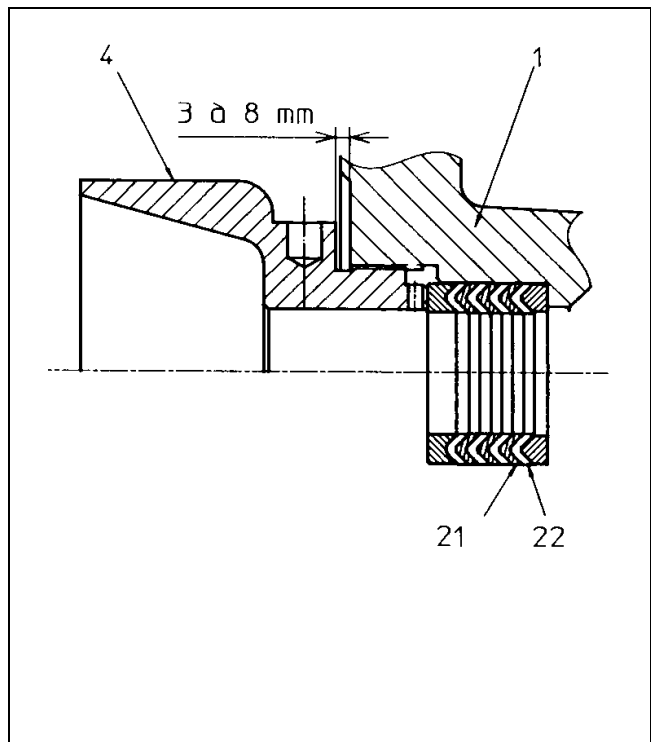

Before reassembling the different components :

- Clean the parts with the appropriate cleaning solvent,
- Install new seals if necessary after having lubricated them with PTFE grease,
- Install new parts if necessary.

ASSEMBLY INSTRUCTIONS (FLUID SECTION, MODEL C100)

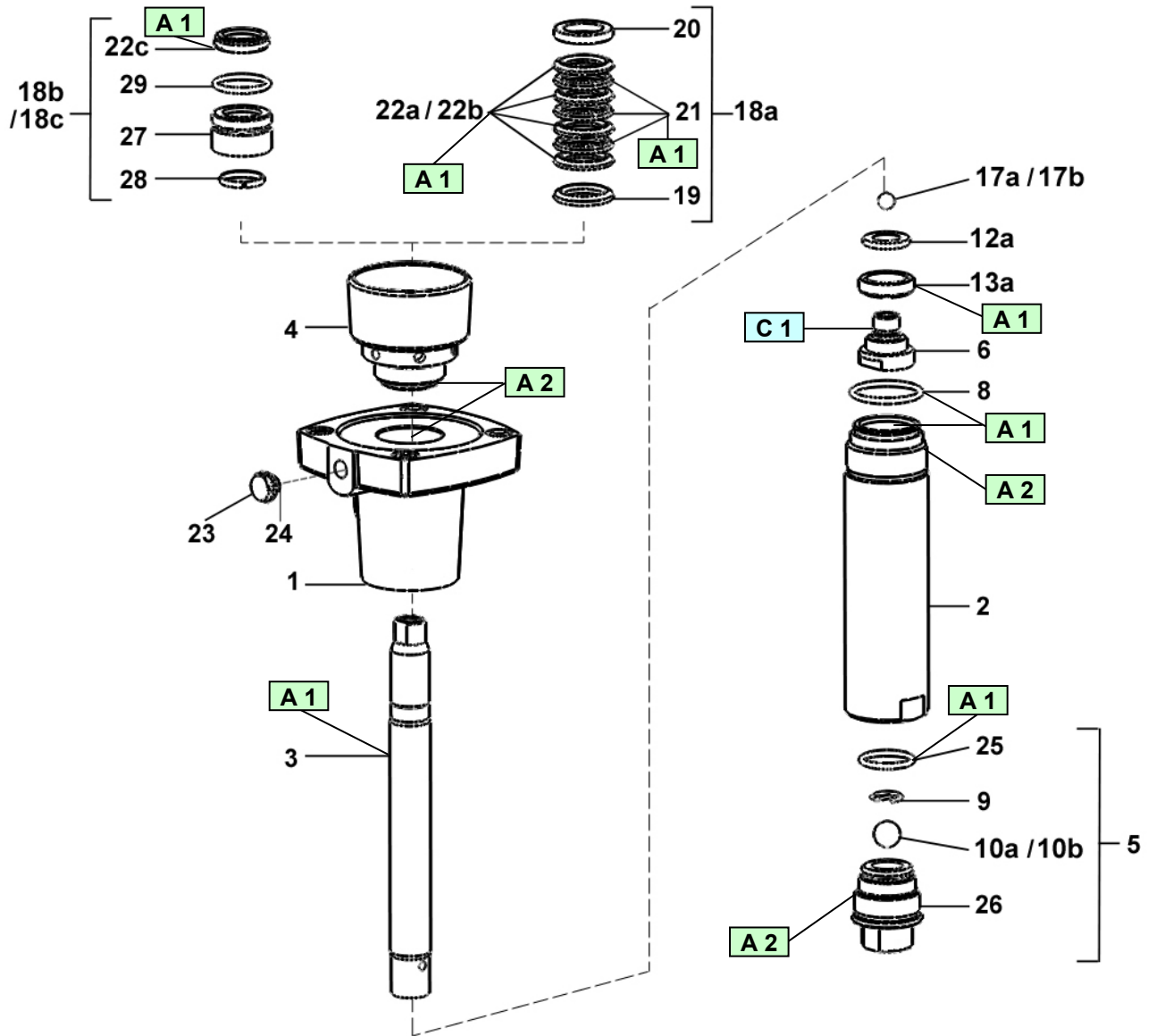

Index	Instruction	Description	Part number
A 1	PTFE grease	'TECHNILUB' grease (10 ml / 0.34 oz)	560.440.101
A 2	Anti-seize grease	Grease box (450 g / 1 lb)	560.420.005
C 1	Medium strength Aneorobic Pipe sealant	Loctite 5772 (50 ml / 1.7 oz)	554.180.015

**Guards (air motor cover, coupling shields, housings ...) have been designed for safe use of the equipment.
The manufacturer will not be held responsible for bodily injury or failure and / or damage to property due to removal or partial removal of the guards.**

1 - DISASSEMBLY / ASSEMBLY OF THE FLUID SECTION PART

Unscrew the fitting nut (38) and the screws (41 and 43) to remove the connection tube (39).

SUCTION VALVE

Unscrew the suction valve (35) holding the cylinder (27).

The ball (22) is secured on the valve (35) by means of a circular rush (21).

Clean the parts.

Reinstall the suction valve (35) and the seal (23) changing parts if necessary.

EXHAUST VALVE AND MOBILE PACKING

Unscrew the cylinder (27) and pull it downwards.

Unscrew the exhaust valve (34) holding the piston (24).

Remove the ball (32) and mobile packing (GT seal - ind. 31).

Clean the parts and reinstall them. Replace seals if necessary.

UPPER TIGHTNESS SEAL

Unscrew the 4 screws (30).

Remove the tightness seal (28) pulling discharge flange (25) downward.

Change the tightness seal (28), the O-Rings (29 and 11).

Reinstall the parts in the reverse order of the disassembly sequence.

2 - DISASSEMBLY - ASSEMBLY OF THE COUPLING (WITH BELLOWS)

That operation must be carried out after the disassembly of the fluid section part.

BELLOWS

Unscrew the nuts (14) from the coupling tie-rods.

Take off the suction flange (1) and the cylinder (2) pulling them downwards.

Remove screws (12) to separate the suction bearing (3) from the motor.

Separate the intermediate piston (9) from the motor rod.

Put aside the coupling with bellows assembly.

Disassemble the bellows' flange (4) removing the screws (13) to take off the upper part from the bellows.

Unscrew the skirt (8) to take off the lower part from the bellows.

Change the bellows (5).

Install the new bellows pushing it into skirt (8) firmly.

Insert the intermediate piston (9) inside the bellows (5) and screw the skirt at its end.

Insert the bellows and the piston (9) into the bearing (3).

Install the flange (4) into bellows (3) and tighten the whole with the screws (13).

Connect bellows-piston assembly with the motor rod and secure it to the lower support of the motor with the screws (12).

Reinstall the fluid section piston (24) on the intermediate piston (9).

Change the seals (11) then reinstall the cylinder (2) and the suction flange (1).

Install the whole on the tie-rods and tighten the nuts (14).

Before reassembling the different components :

- Clean the parts with the appropriate cleaning solvent,
- Install new seals if necessary, after having lubricated them with PTFE grease,
- Lubricate the piston and the inside of the cylinder to prevent from damaging the seals,
- Install new parts if necessary.

ASSEMBLY INSTRUCTIONS

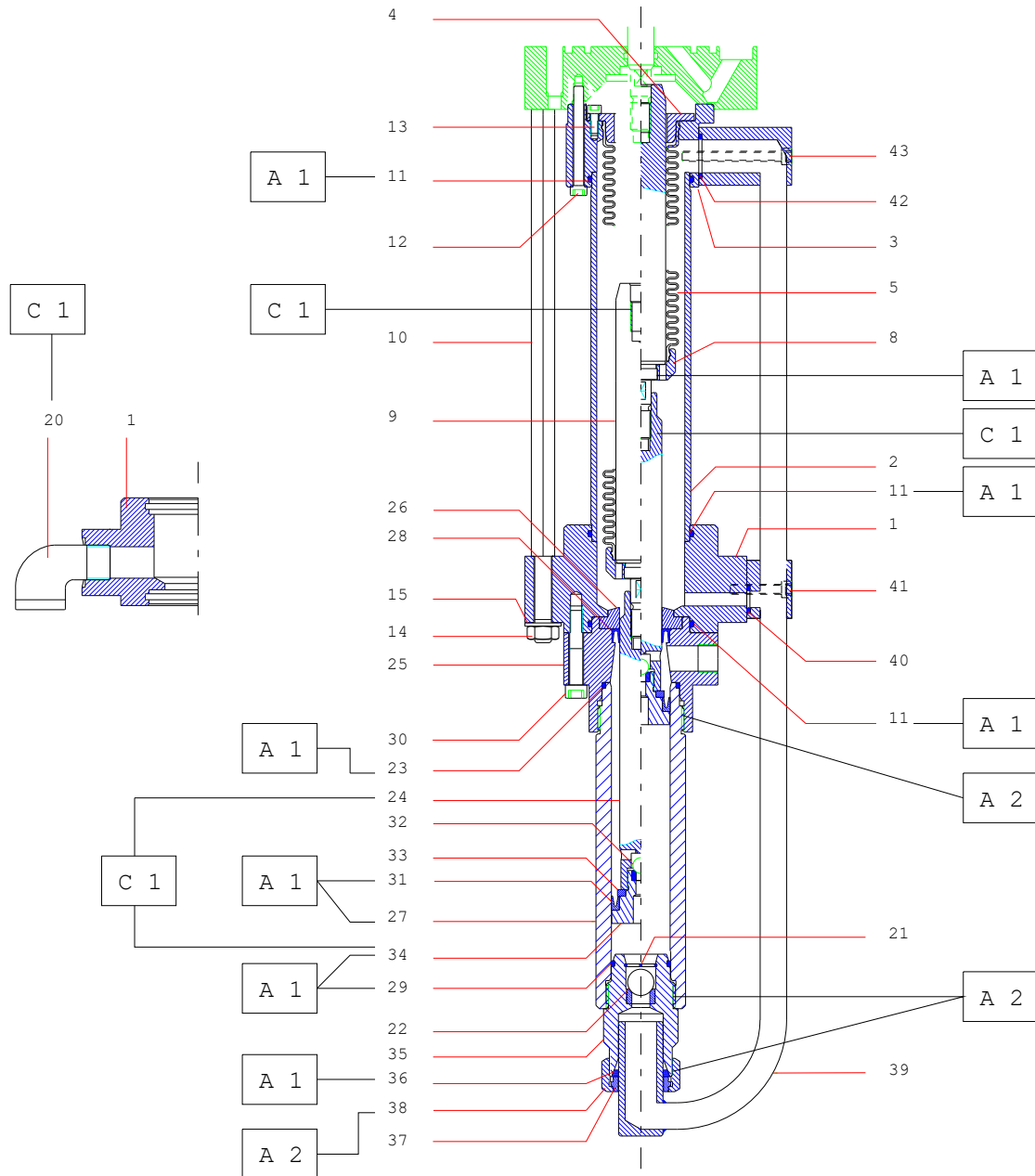

Index	Instruction	Description	Part number
A 1	PTFE grease	'TECHNILUB' grease (10 ml / 0.34 oz)	560.440.101
A 2	Anti-seize grease	Grease box (450 g / 1 lb)	560.420.005
C 1	Medium strength Aneorobic Pipe sealant	Loctite 5772 (50 ml / 1.7 oz)	554.180.015

SPECIFICATIONS

PU 3000 PUMP - model Airless

18. FEATURES - PU 3000 AIRLESS

■ COMPOSITION

BASE pump	Motor :	5000 (only for PU 3000)
	Fluid section :	50 cc (standard)
CATALYST pump	Motor :	5000 (only for PU 3000)
	Fluid section :	50 cc (standard)
Flushing pump	Option :	Flushing pump, model 30-C25

■ TECHNICAL FEATURES

Maximum air supply pressure	6 bar / 87 psi
Maximum fluid outlet pressure of the PU 3000	360 bar / 5222 psi
Proportioning ratio / Fluid flow rate	Refer to charts (§ 12 & 13)
Electrical supply of the supply unit	115V / 230V - 10W
Air inlet connection	F 3/4 BSP (air inlet valve)
Fluid outlet connection (mixer)	F 3/4 JIC



The control box of the PU 3000 mixing machine must be installed outside the spray booth.

■ SPECIFIC PARAMETERS

Parameters	Description	Factory adjustment	Your adjustments
F3- -P4	Section of the A piston Minimum value : 1 mm ² Maximum value : 99 999 mm ²	555 (for fluid section, model 50cc)	
F3- -P5	Section of the B piston Minimum value : 1 mm ² Maximum value : 99 999 mm ²	555 (for fluid section, model 50cc)	

19. DISASSEMBLY & REASSEMBLY - PU 3000 AIRLESS



CAUTION : Before any work is carried on the pump, stop the machine after carrying out flushing, shut off the compressed air supply and depressurize the circuits triggering the gun.

The pump is manufactured under the ATEX agreement and can not be modified. SAMES KREMLIN will not be held responsible for any failure to comply with that instruction.

■ MIXER

Unscrew the mixer assembly and replace it with a new one.

■ ASI 40 VALVES (REFER TO DOC. 573.062.050)

FLUID PACKING (IND. 22) AND NEEDLE WITH BALL (IND. 37)

Unscrew the diaphragm (9), the seat-holder assembly (17).

Remove the 2 screws (13).

Remove gun front body (1) by separating needle holder (23) and needle (20) from rod (6).

Remove clip (26) holding fluid packing (22).

Remove fluid packing (22) by pulling the needle frontwards.

Unscrew ball needle (37) from needle holder (23).

Change fluid packing and its seal (24).

Clean the front part of the gun.

When reinstalling, drive fluid packing (22) by pushing it from the front to the rear part of the body (1) until the packing shoulder comes to lean against the shoulder located inside the gun.

Then, secure the fluid packing by means of the clip (26).

Reinstall ball needle (37), screws (13), seat-holder assembly (17), diaphragm (9), tip and coupling nut (8).

PISTON ASSEMBLY (IND. 27)

Unscrew the 4 screws (11).

Remove spring guide (3) and cylinder (2).

Take off spring (7) and spring support (33).

Unscrew nut (31).

Remove washer (30) and piston packing (29).

Clean the parts and change them if necessary.

Nota : Before inserting the piston assembly (27) into the cylinder, the packing lip (29) must be shaped by hand as shown opposite (cartridge turned up on the piston).

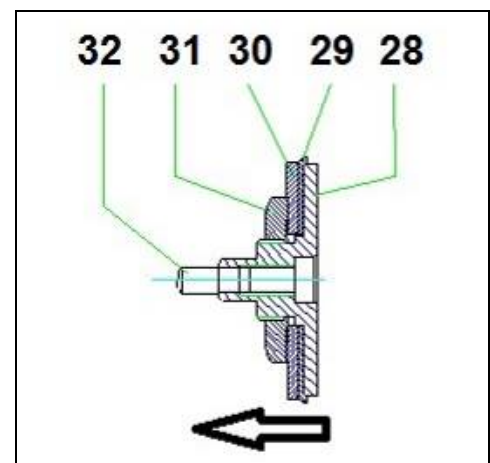

AIR PACKING (IND. 34)

Dismount the back part of the gun and remove the piston as explained before.

Remove air packing (34).

Replace packing seal (36) or the air packing assembly.

Nota : when changing the ASI 40 valve from the PU 3000 fluid equipment, take off the fittings from the spare valve delivered, then install it on the fluid equipment.



WARNING!

Before any action on the pump, shut off the compressed air supply and depressurize the systems by triggering the spray gun.

Guards (air motor cover, coupling shields, housings ...) have been designed for safe use of the equipment.

The manufacturer will not be held responsible for bodily injury or failure and / or damage to property due to removal or partial removal of the guards.

Disassembly of the pump

- Unscrew the 2 nuts (22) and put aside the flange (20), the tie-rods (21) and the protective housing (23),
- Clamp the pump horizontally through the body (2) into a vice,
- Unscrew the valve body assembly (14),
- Take off the piston (8) downwards,
- Put aside the cylinder (7).

Lower valve

- Push on the ball (16) to remove the spacer (17),
 - Take off the seat (15), the seal (19) and the pin (18),
 - Put aside the seal (13),
 - Clean the parts, check them if they are not worn or damaged.
- Reinstall the parts in the reverse order of the disassembly sequence.

Cup seals

- Unscrew the cup nut (1),
 - Take off the washers (3 & 5),
 - Put aside the seals: PTFEG seals (4a) & UHMW seals (4b),
 - Clean the parts, check them if they are not worn or damaged.
- Reinstall the parts in the reverse order of the disassembly sequence

Piston head seals

- Unscrew the seat (10),
- Take off the ball (11), the washers (3 & 5) and the seals (12),
- Change the seals : PTFE G seals (12a) & UHMW seals (12b),
- Clean the parts, check them if they are not worn or damaged.

Complete assembly of the fluid section

- Lubricate the cup seals and the piston head seals,
- Slide the piston rod assembly (8) inside the body (2), push it upwards,
- Screw the cylinder (7) (to stop) into the body (2),
- Screw the valve body assembly (14) to stop, tighten slightly,
- Reinstall the protective housing (23), the connection flange (20) and the tie-rods (21). Screw the two nuts (22),
- Assemble the pump to the pneumatic motor.

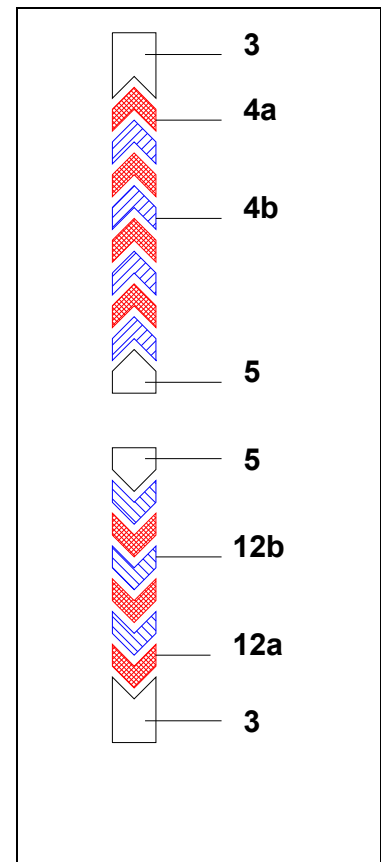

Before intervening on the equipment :

- Clean the parts with the appropriate cleaning solvent,
- Install new seals if necessary, after having lubricated them with grease,
- Lubricate the piston and the inside of the cylinder to prevent from damaging the seals,
- Install new parts if necessary.

ASSEMBLY INSTRUCTIONS (FLUID SECTION, MODEL 50cc)

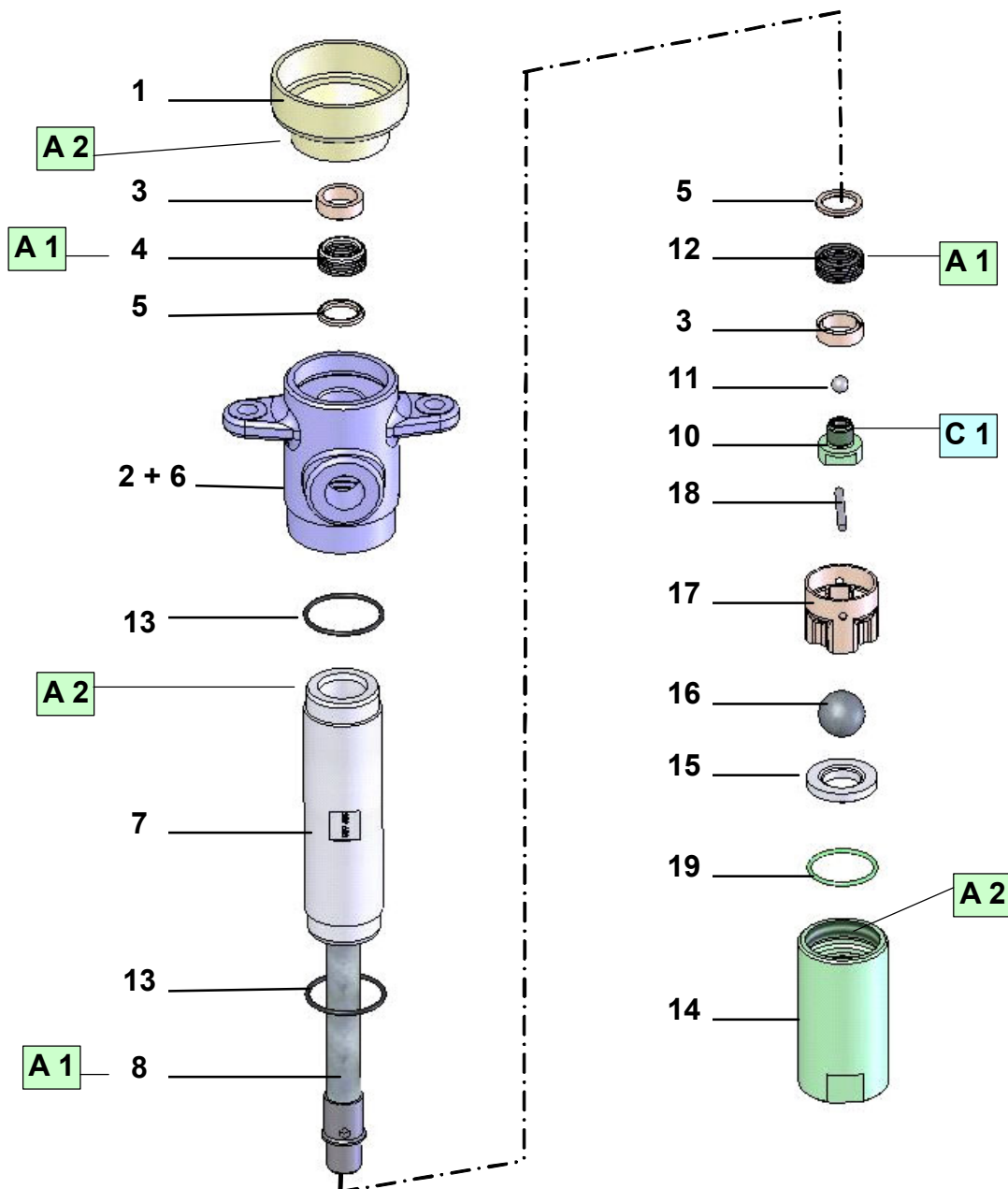

Index	Instruction	Description	Part number
A 1	PTFE grease	'TECHNILUB' grease (10 ml / 0.34 oz)	560.440.101
A 2	Anti-seize grease	Grease box (450 g / 1 lb)	560.420.005
C 1	Medium strength Aneorobic Pipe sealant	Loctite 5772 (50 ml / 1.7 oz)	554.180.015

SPECIFICATIONS

PU 3000 PUMP - model 4 L 30/1

20. FEATURES - PU 3000 4 L 30/1

■ COMPOSITION

BASE pump	Motor :	5000 (only for PU 3000)
	Fluid section :	225cc (standard)
CATALYST pump	Motor :	5000 (only for PU 3000)
	Fluid section :	225cc (standard)
Flushing pump	Option :	Flushing pump, model 30-C25

■ TECHNICAL FEATURES

Maximum air supply pressure	6 bar / 87 psi
Maximum fluid outlet pressure of the PU 3000	180 bar / 2610.5 psi
Proportioning ratio / Fluid flow rate	Refer to charts (§ 12 & 13)
Electrical supply of the supply unit	115V / 230V - 10W
Air inlet connection	F 3/4 BSP (air inlet valve)
Fluid outlet connection (mixer)	F 3/4 JIC



The control box of the PU 3000 mixing machine must be installed outside the spray booth.

■ SPECIFIC PARAMETERS

Parameters	Description	Factory adjustment	Your adjustments
F3- -P4	Section of the A piston Minimum value: 1 mm ² Maximum value : 99 999 mm ²	1010 (for fluid section, model 225cc)	
F3- -P5	Section of the B piston Minimum value: 1 mm ² Maximum value : 99 999 mm ²	1010 (for fluid section, model 225cc)	

21. DISASSEMBLY & REASSEMBLY - PU 3000 4 L 30/1



CAUTION : Before any work is carried on the pump, stop the machine after carrying out flushing, shut off the compressed air supply and depressurize the circuits triggering the gun.

The pump is manufactured under the ATEX agreement and can not be modified. SAMES KREMLIN will not be held responsible for any failure to comply with that instruction.

■ MIXER

Unscrew the mixer assembly and replace it with a new one.

■ ASI 40 VALVES (REFER TO DOC. 573.062.050)

FLUID PACKING (IND. 22) AND NEEDLE WITH BALL (IND. 37)

Unscrew the diaphragm (9), the seat-holder assembly (17).

Remove the 2 screws (13).

Remove gun front body (1) by separating needle holder (23) and needle (20) from rod (6).

Remove clip (26) holding fluid packing (22).

Remove fluid packing (22) by pulling the needle frontwards.

Unscrew ball needle (37) from needle holder (23).

Change fluid packing and its seal (24).

Clean the front part of the gun.

When reinstalling, drive fluid packing (22) by pushing it from the front to the rear part of the body (1) until the packing shoulder comes to lean against the shoulder located inside the gun.

Then, secure the fluid packing by means of the clip (26).

Reinstall ball needle (37), screws (13), seat-holder assembly (17), diaphragm (9), tip and coupling nut (8).

PISTON ASSEMBLY (IND. 27)

Unscrew the 4 screws (11).

Remove spring guide (3) and cylinder (2).

Take off spring (7) and spring support (33).

Unscrew nut (31).

Remove washer (30) and piston packing (29).

Clean the parts and change them if necessary.

Nota : Before inserting the piston assembly (27) into the cylinder, the packing lip (29) must be shaped by hand as shown opposite (cartridge turned up on the piston).

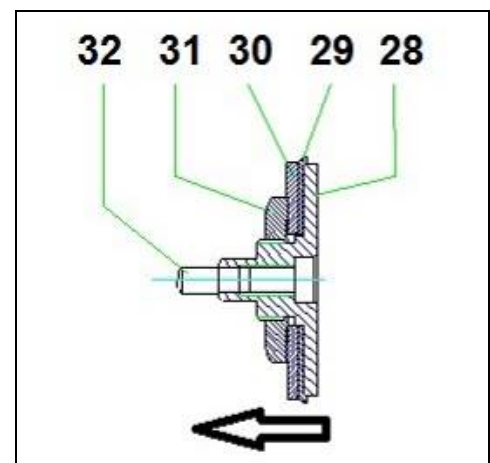

AIR PACKING (IND. 34)

Dismount the back part of the gun and remove the piston as explained before.

Remove air packing (34).

Replace packing seal (36) or the air packing assembly.

Nota : when changing the ASI 40 valve from the PU 3000 fluid equipment, take off the fittings from the spare valve delivered, then install it on the fluid equipment.



WARNING!

Before any action on the pump, shut off the compressed air supply and depressurize the systems by triggering the spray gun.

Guards (air motor cover, coupling shields, housings ...) have been designed for safe use of the equipment.

The manufacturer will not be held responsible for bodily injury or failure and / or damage to property due to removal or partial removal of the guards.

Disassembly of the pump

- Unscrew the 2 nuts (16) and put aside the flange (1), the tie-rods (10) and the protective housing (4),
- Clamp the pump horizontally through the body (7) into a vice,
- Unscrew the valve body assembly (23),
- Take off the piston (11) downwards,
- Put aside the cylinder (21).

Lower valve

- Push on the ball (19) to remove the spacer (18),
 - Take off the seat (20), the seal (22) and the pin (24),
 - Put aside the seal (9),
 - Clean the parts, check them if they are not worn or damaged.
- Reinstall the parts in the reverse order of the disassembly sequence.

Cup seals

- Unscrew the cup nut (5),
 - Take off the washers (6 & 13),
 - Put aside the seals: PE seals (12a) & PTFE G seals (12b),
 - Clean the parts, check them if they are not worn or damaged.
- Reinstall the parts in the reverse order of the disassembly sequence.

Piston head seals

- Unscrew the seat (17),
- Take off the ball (15), the washers (6 & 13) and the seals (12),
- Change the seals: PE seals (12a) & PTFE G seals (12b),
- Clean the parts, check them if they are not worn or damaged.

Complete assembly of the fluid section

- Lubricate the cup seals and the piston head seals,
- Slide the piston rod assembly (11) inside the body (7), push it upwards,
- Screw the cylinder (21) (to stop) into the body (7),
- Screw the valve body assembly (23) to stop, tighten slightly,
- Reinstall the protective housing (4), the connection flange (1) and the tie-rods (10). Screw the two nuts (16),
- Assemble the pump to the pneumatic motor.

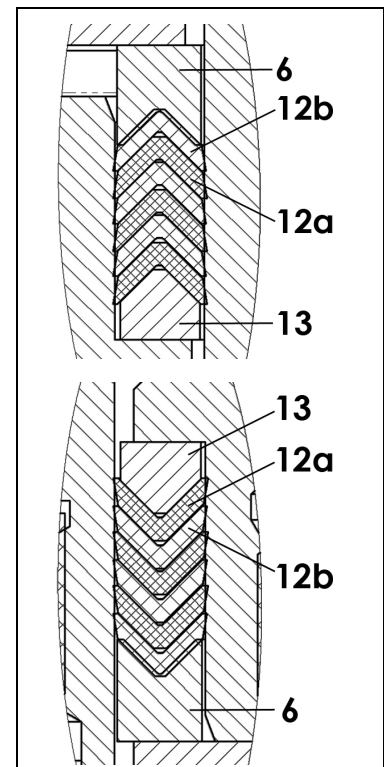

Before intervening on the equipment :

- Clean the parts with the appropriate cleaning solvent,
- Install new seals if necessary, after having lubricated them with grease,
- Lubricate the piston and the inside of the cylinder to prevent from damaging the seals,
- Install new parts if necessary.

ASSEMBLY INSTRUCTIONS (FLUID SECTION, MODEL 225CC)

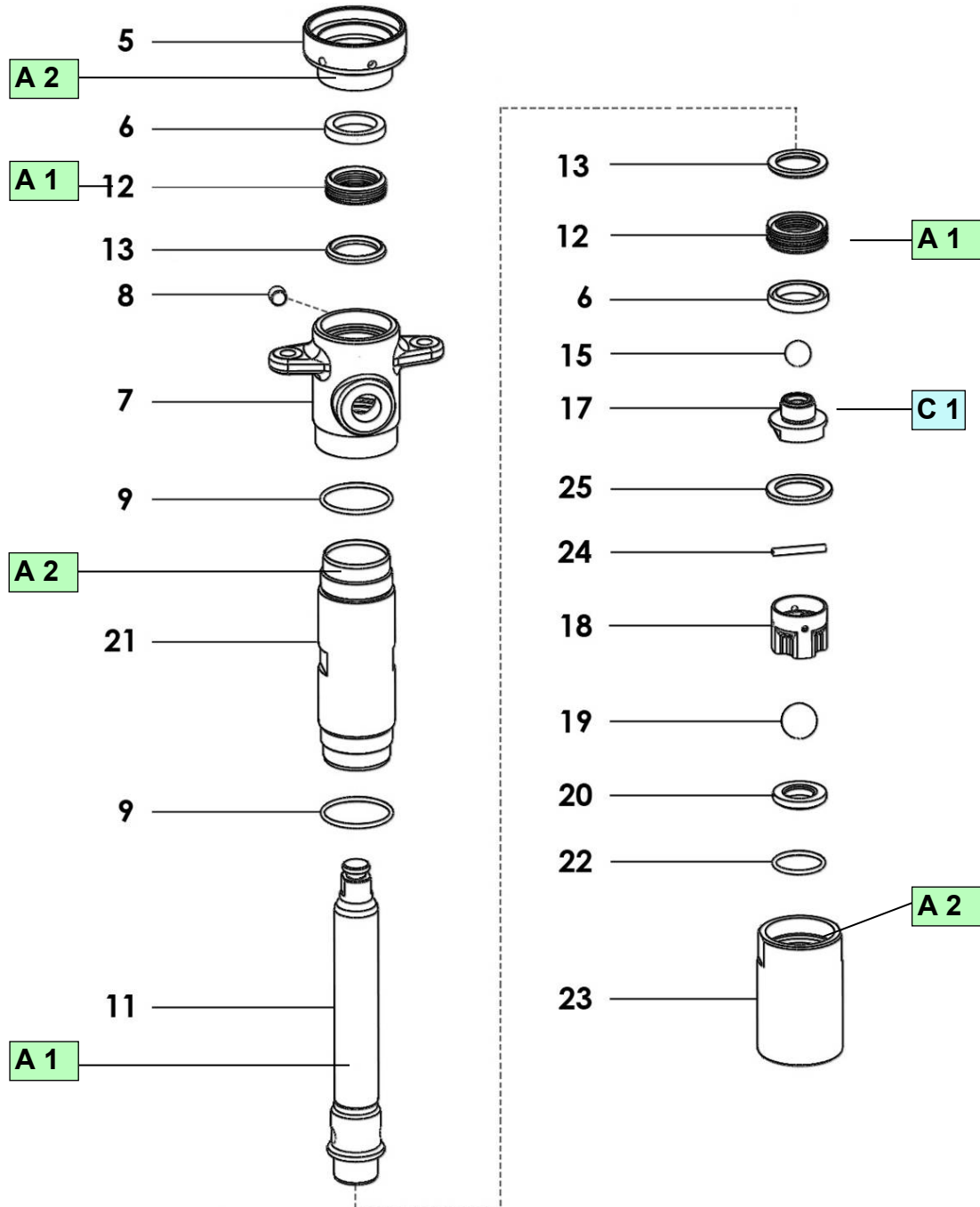

Index	Instruction	Description	Part number
A 1	PTFE grease	'TECHNILUB' grease (10 ml / 0.34 oz)	560.440.101
A 2	Anti-seize grease	Grease box (450 g / 1 lb)	560.420.005
C 1	Medium strength Aneorobic Pipe sealant	Loctite 5772 (50 ml / 1.7 oz)	554.180.015

SPECIFICATIONS

PU 3000 PUMP - model 4 L 53/1

22. FEATURES - PU 3000 4 L 53/1

■ COMPOSITION

BASE pump	Motor :	7000 (only for PU 3000)
	Fluid section :	227cc (standard)
CATALYST pump	Motor :	7000 (only for PU 3000)
	Fluid section :	227cc (standard)
Flushing pump	Option :	Flushing pump, model 30-C25

■ TECHNICAL FEATURES

Maximum air supply pressure	6 bar / 87 psi
Maximum fluid outlet pressure of the PU 3000	350 bar / 5076 psi
Proportioning ratio / Fluid flow rate	Refer to charts (§ 12 & 13)
Electrical supply of the supply unit	115V / 230V - 10W
Air inlet connection	F 3/4 BSP (air inlet valve)
Fluid outlet connection (mixer)	F 3/4 JIC



The control box of the PU 3000 mixing machine must be installed outside the spray booth.

■ SPECIFIC PARAMETERS

Parameters	Description	Factory adjustment	Your adjustments
F3- -P4	Section of the A piston Minimum value : 1 mm ² Maximum value : 99 999 mm ²	1025 (for fluid section, model 227cc)	
F3- -P5	Section of the B piston Minimum value : 1 mm ² Maximum value : 99 999 mm ²	1025 (for fluid section, model 227cc)	

23. DISASSEMBLY & REASSEMBLY - PU 3000 4 L 53/1



CAUTION : Before any work is carried on the pump, stop the machine after carrying out flushing, shut off the compressed air supply and depressurize the circuits triggering the gun.

The pump is manufactured under the ATEX agreement and can not be modified. SAMES KREMLIN will not be held responsible for any failure to comply with that instruction.

■ MIXER

Unscrew the mixer assembly and replace it with a new one.

■ ASI 40 VALVES (REFER TO DOC. 573.062.050)

FLUID PACKING (IND. 22) AND NEEDLE WITH BALL (IND. 37)

Unscrew the diaphragm (9), the seat-holder assembly (17).

Remove the 2 screws (13).

Remove gun front body (1) by separating needle holder (23) and needle (20) from rod (6).

Remove clip (26) holding fluid packing (22).

Remove fluid packing (22) by pulling the needle frontwards.

Unscrew ball needle (37) from needle holder (23).

Change fluid packing and its seal (24).

Clean the front part of the gun.

When reinstalling, drive fluid packing (22) by pushing it from the front to the rear part of the body (1) until the packing shoulder comes to lean against the shoulder located inside the gun.

Then, secure the fluid packing by means of the clip (26).

Reinstall ball needle (37), screws (13), seat-holder assembly (17), diaphragm (9), tip and coupling nut (8).

PISTON ASSEMBLY (IND. 27)

Unscrew the 4 screws (11).

Remove spring guide (3) and cylinder (2).

Take off spring (7) and spring support (33).

Unscrew nut (31).

Remove washer (30) and piston packing (29).

Clean the parts and change them if necessary.

Nota : Before inserting the piston assembly (27) into the cylinder, the packing lip (29) must be shaped by hand as shown opposite (cartridge turned up on the piston).

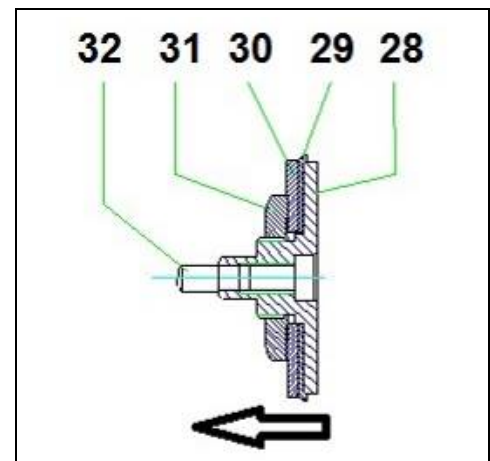

AIR PACKING (IND. 34)

Dismount the back part of the gun and remove the piston as explained before.

Remove air packing (34).

Replace packing seal (36) or the air packing assembly.

Nota : when changing the ASI 40 valve from the PU 3000 fluid equipment, take off the fittings from the spare valve delivered, then install it on the fluid equipment.

■ FLUID SECTION, MODEL MAJOR 227CC # 105 174 01 07 (BASE & CATALYST)
(REFER TO DOC. 573.447.050)



WARNING!

Before any action on the pump, shut off the compressed air supply and depressurize the systems by triggering the spray gun.

Guards (air motor cover, coupling shields, housings ...) have been designed for safe use of the equipment.

The manufacturer will not be held responsible for bodily injury or failure and / or damage to property due to removal or partial removal of the guards.

Disassembly of the pump

- Unscrew the 4 nuts (16) and put aside the flange (1), the tie-rods (14) and the protection (4),
- Clamp the pump horizontally through the body (7) with a vice,
- Unscrew the foot valve body assembly (26),
- Take off the piston rod (15) downwards,
- Put aside the cylinder (10).

Lower valve

- Unscrew the body of the foot valve body (26),
- Take off the ball cage (19) and the ball (22),
- Take off the seat (23) and the seals (24 & 25).
- Clean all the parts, check them; if there are damaged or worn, change them.

Reinstall the parts in the reverse order of the disassembly sequence.

Cup seals

Nota : the pump body (7) consists of a cartridge (7b) to make easier the changing of the seals.

- Unscrew the cup nut (5),
- Take off the 10 screws (7d) that tighten the cartridge (7b) in the body (7a),
- Take off the cartridge (7b) screwing the extractors in the 2 M8 holes in the cartridge,
- Take off the washers (6 & 12), and the seals (11),
- Change the seals: PE seals (11b) & PTFE G seals (11d),
- Change the seal (7c).

Clean all the parts, check them; if there are damaged or worn, change them.

Reinstall the parts in the reverse order of the disassembly sequence.

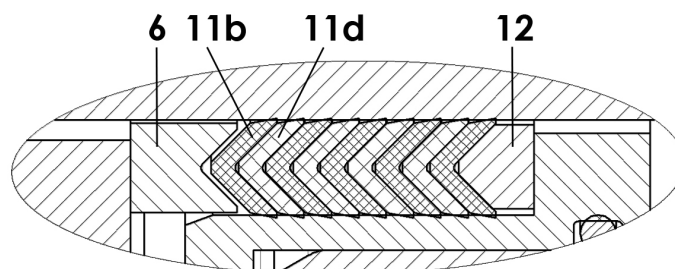
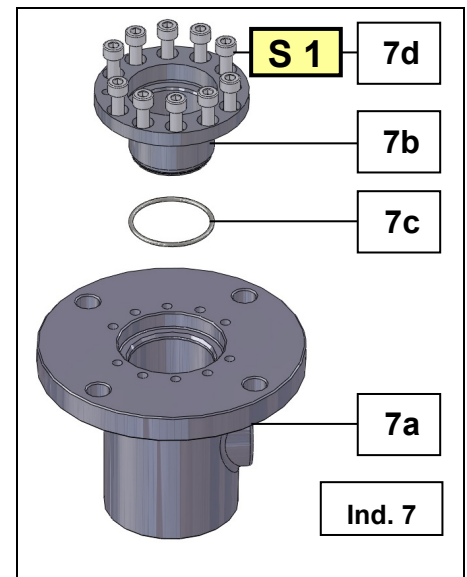

Piston rod seals

- Unscrew the seat (18),
- Take off the ball (17), the washers (12 & 16), the seals: PE seals (11b) & PTFE G seals (11d) and the adjustment blocks (27),
- Clean all the parts, check them; if there are damaged or worn, change them.

Reinstall the parts in the reverse order of the disassembly sequence.

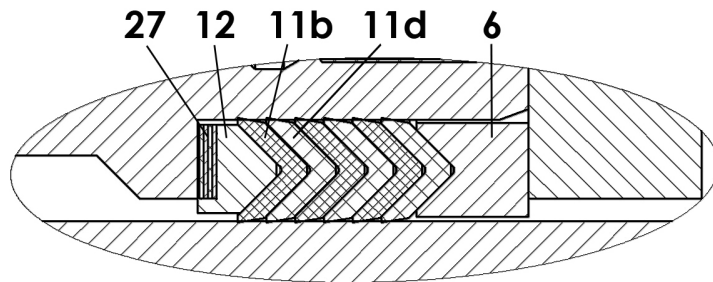

Complete assembly of the fluid section

- Lubricate the cup seals and piston rod seals,
- Slide the piston rod assembly (15) inside the body (7), push it upwards,
- Screw the cylinder (10) into the body (7),
- Screw the foot valve body assembly (26). Tighten slightly,
- Reinstall the protective housing (4), the connecting flange (1) and the tie-rods (14). Screw the 4 nuts (16).
- Couple the fluid section to the pneumatic motor.

Before intervening on the equipment :

- **Clean the parts with the appropriate cleaning solvent,**
- **Install new seals if necessary after having lubricated them,**
- **Lubricate the piston and the inside of the cylinder to prevent from damaging the seals,**
- **Install new parts if necessary.**

Adjustment of the suction valve ball cage screw :

Depending upon the fluid viscosity to be pumped, adjust the height of the screw (19c) to increase the ball up motion.

Lock the screw (apply Loctite 5772) on the lock nut (19b).

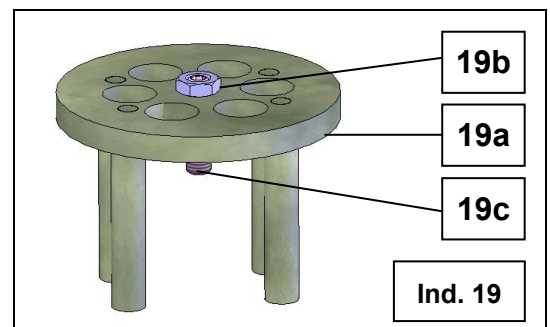

ASSEMBLY INSTRUCTIONS (FLUID SECTION, MODEL 227CC)

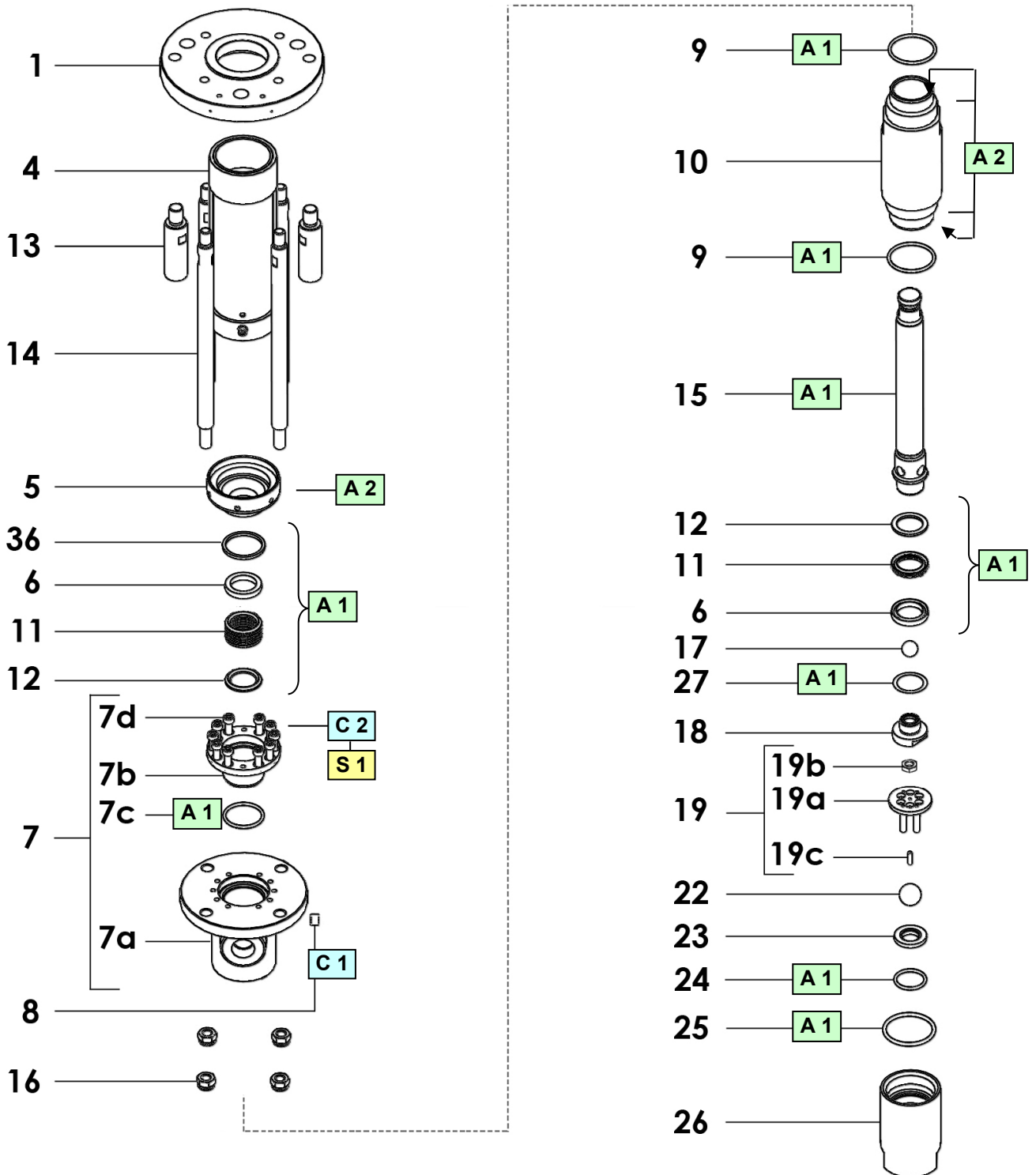

Index	Instruction	Description	Part number
A 1	PTFE grease	'TECHNILUB' grease (10 ml / 0.34 oz)	560.440.101
A 2	Anti-seize grease	Grease box (450 g / 1 lb)	560.420.005
C 1	Medium strength Aneorbic Pipe sealant	Loctite 5772 (50 ml / 1.7 oz)	554.180.015
S 1	Screwing torque : 20 Nm / 14.75 ft/lbs		

SPECIFICATIONS

PU 3000 PUMP - model 4 L Flowmax® 53/1

24. FEATURES - PU 3000 4 L FLOWMAX® 53/1

■ COMPOSITION

BASE pump	Motor :	7000-F (only for PU 3000)
	Fluid section :	C260 (standard)
CATALYST pump	Motor :	7000-F (only for PU 3000)
	Fluid section :	F260 (standard)
Flushing pump	Option :	Flushing pump, model 30-C25

■ TECHNICAL FEATURES

Maximum air supply pressure	6 bar / 87 psi
Maximum fluid outlet pressure of the PU 3000	360 bar / 5222 psi
Proportioning ratio / Fluid flow rate	Refer to charts (§ 12 & 13)
Electrical supply of the supply unit	115V / 230V - 10W
Air inlet connection	F 3/4 BSP (air inlet valve)
Fluid outlet connection (mixer)	F 3/4 JIC



The control box of the PU 3000 mixing machine must be installed outside the spray booth.

■ SPECIFIC PARAMETERS

Parameters	Description	Factory adjustment	Your adjustments
F3- -P4	Section of the A piston Minimum value : 1 mm ² Maximum value : 99 999 mm ²	1060 (for fluid section, model C260)	
F3- -P5	Section of the B piston Minimum value : 1 mm ² Maximum value : 99 999 mm ²	1100 (for fluid section, model F260)	

25. DISASSEMBLY & REASSEMBLY - PU 3000 4 L FLOWMAX® 53/1



CAUTION : Before any work is carried on the pump, stop the machine after carrying out flushing, shut off the compressed air supply and depressurize the circuits triggering the gun.

The pump is manufactured under the ATEX agreement and can not be modified. SAMES KREMLIN will not be held responsible for any failure to comply with that instruction.

■ MIXER

Unscrew the mixer assembly and replace it with a new one.

■ ASI 40 VALVES (REFER TO DOC. 573.062.050)

FLUID PACKING (IND. 22) AND NEEDLE WITH BALL (IND. 37)

Unscrew the diaphragm (9), the seat-holder assembly (17).

Remove the 2 screws (13).

Remove gun front body (1) by separating needle holder (23) and needle (20) from rod (6).

Remove clip (26) holding fluid packing (22).

Remove fluid packing (22) by pulling the needle frontwards.

Unscrew ball needle (37) from needle holder (23).

Change fluid packing and its seal (24).

Clean the front part of the gun.

When reinstalling, drive fluid packing (22) by pushing it from the front to the rear part of the body (1) until the packing shoulder comes to lean against the shoulder located inside the gun.

Then, secure the fluid packing by means of the clip (26).

Reinstall ball needle (37), screws (13), seat-holder assembly (17), diaphragm (9), tip and coupling nut (8).

PISTON ASSEMBLY (IND. 27)

Unscrew the 4 screws (11).

Remove spring guide (3) and cylinder (2).

Take off spring (7) and spring support (33).

Unscrew nut (31).

Remove washer (30) and piston packing (29).

Clean the parts and change them if necessary.

Nota : Before inserting the piston assembly (27) into the cylinder, the packing lip (29) must be shaped by hand as shown opposite (cartridge turned up on the piston).

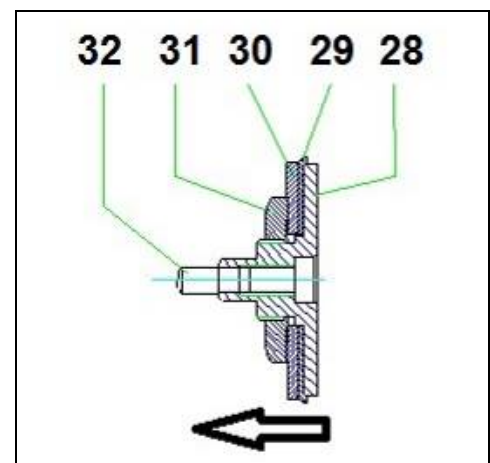

AIR PACKING (IND. 34)

Dismount the back part of the gun and remove the piston as explained before.

Remove air packing (34).

Replace packing seal (36) or the air packing assembly.

Nota : when changing the ASI 40 valve from the PU 3000 fluid equipment, take off the fittings from the spare valve delivered, then install it on the fluid equipment.

■ FLUID SECTION, MODEL C260 (BASE) (REFER TO DOC. 573.414.050)



WARNING!

Before any action on the pump, shut off the compressed air supply and depressurize the systems by triggering the spray gun.

Suction valve (15)

Disassembly

Unscrew the suction valve (16). (If the cylinder (2) remains attached to the suction valve, unscrew both parts, then hold cylinder (2) by inserting a rod into the cylinder holes designed for this purpose).

The ball (17) is secured on the valve (16) by means of a circlips (18).

Clean the parts with the appropriate cleaning solvent.

Reassembly

Reinstall the ball (17) and the circlips (18) on the valve body (16).

Change the seal (19). Lubricate it.

Lubricate the valve body threading.

Reinstall the valve assembly (15) on the cylinder (2).

Cylinder (2)

In order to make easier the disassembly, a hole is made in the cylinder (2) at each end.

Depending on the part that it is unscrewed first, insert a rod into one of these holes to unscrew the other part.

When reassembling, make sure the two seals (19 and 25) are installed. Lubricate them.

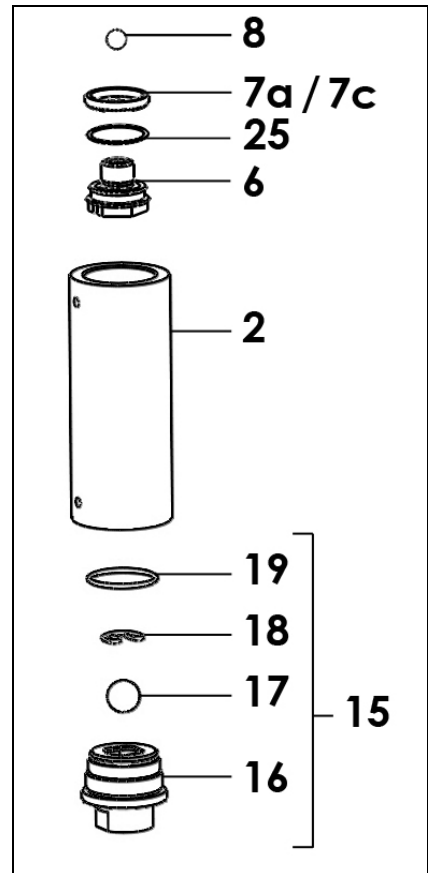

Lubricate the inside of the cylinder (grease, type A1) and the threadings to prevent from damaging the mobile packing (grease, type A2) (Refer to greases in the Assembly instructions §).

Exhaust valve (6) and mobile packing (7)

Disassembly

Unscrew the cylinder (2) and pull it downwards.

Unscrew the exhaust valve (6) with a flat wrench n° 46 by holding the piston (3).

Remove the ball (8), the mobile packing (seal - 7a/7c).

Clean the parts.

Reassembly

Install a new seal (7a/7c). Lubricate it.

➤ **Comply with the seal installation order.**

Install the ball (8) on the exhaust valve (6).

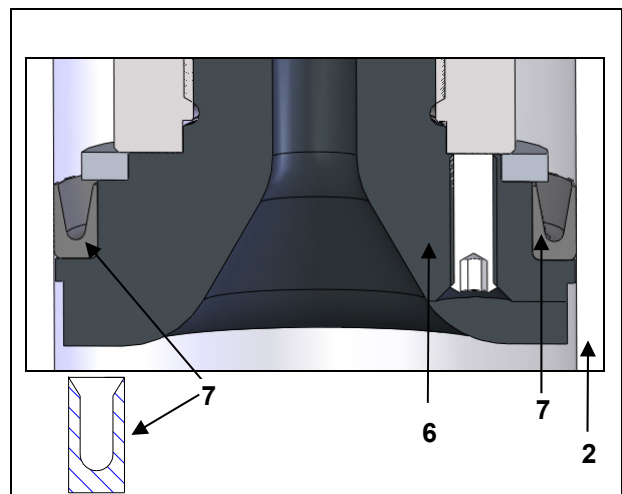

Lubricate the threading of the exhaust valve (grease, type A2).

Tighten the whole in the piston lower part (3).

Upper packing (9)

Disassembly

Disassemble the coupling rod from the air motor and the piston (3) from the fluid section.

Unscrew the wetting-cup (4) by means of the wrench provided with the pump.

Unscrew the cylinder (2) and pull the piston (3) downwards. Pull the upper packing (9) upwards and remove the seals (10 and 11).

Reassembly

 Change the seals (10 & 11) and lubricate them.

On the support washer (12), install the seals (10 & 11) (**comply with orientation and order**) as well as the blocking washer (13) {→ upper packing (9)}.

You must install a seal (11), then another one (10) according to the opposite drawing. The first seal in contact with the material must be the stiffer one.

 Grease the cone shaped tool (the tool is supplied with the fluid section).

Position the upper packing (9) on the tool (53).

Slide the piston (3) into the flange (1) by inserting it from bottom to top.

Position the tool equipped with the seals on the upper part of the piston.

Slide the seals on the piston. The tool prevents from damaging the seals when assembling the piston.

Remove the tool.

Position the seals (always set up on the piston) into the upper flange (1).

 **Hold the piston to prevent from its sliding downwards.**

Tighten by hand the wetting-cup (4) without tightening the upper flange (1).

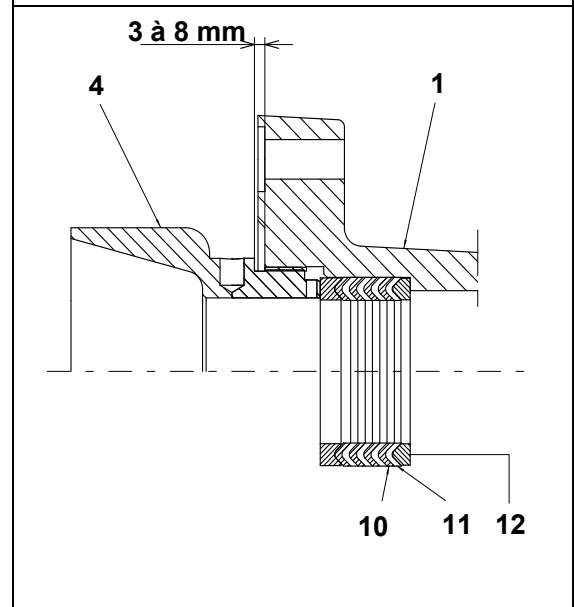
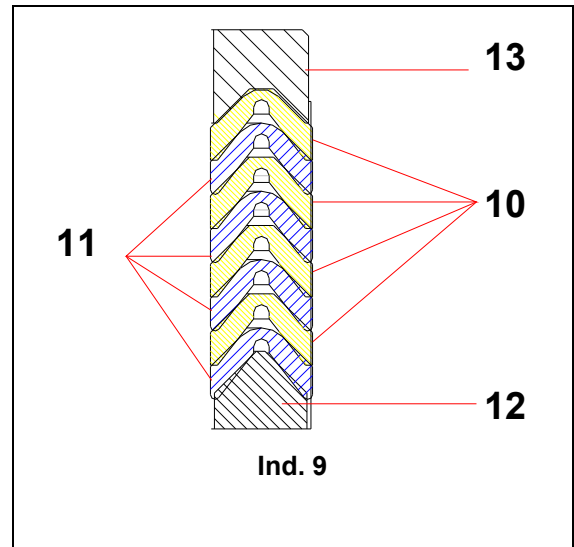

After reassembling, fill up the pump with solvent and increase progressively the pressure to maximum → setting up of the seals.

After half an hour, stop the pump and open the exhaust valve to depressurize.

Retighten the wetting-cup (4) by means of the wrench supplied with the pump in order to be in accordance with the drawing. Comply with assembly dimension.

Before reassembling the different components :

- Clean the parts with the appropriate cleaning solvent.
- Install the new seals if it is necessary after having lubricated them with PTFE grease.
- Lubricate the piston and the inside of the cylinder to prevent from damaging the seals.
- Install new parts if it is necessary.

ASSEMBLY INSTRUCTIONS

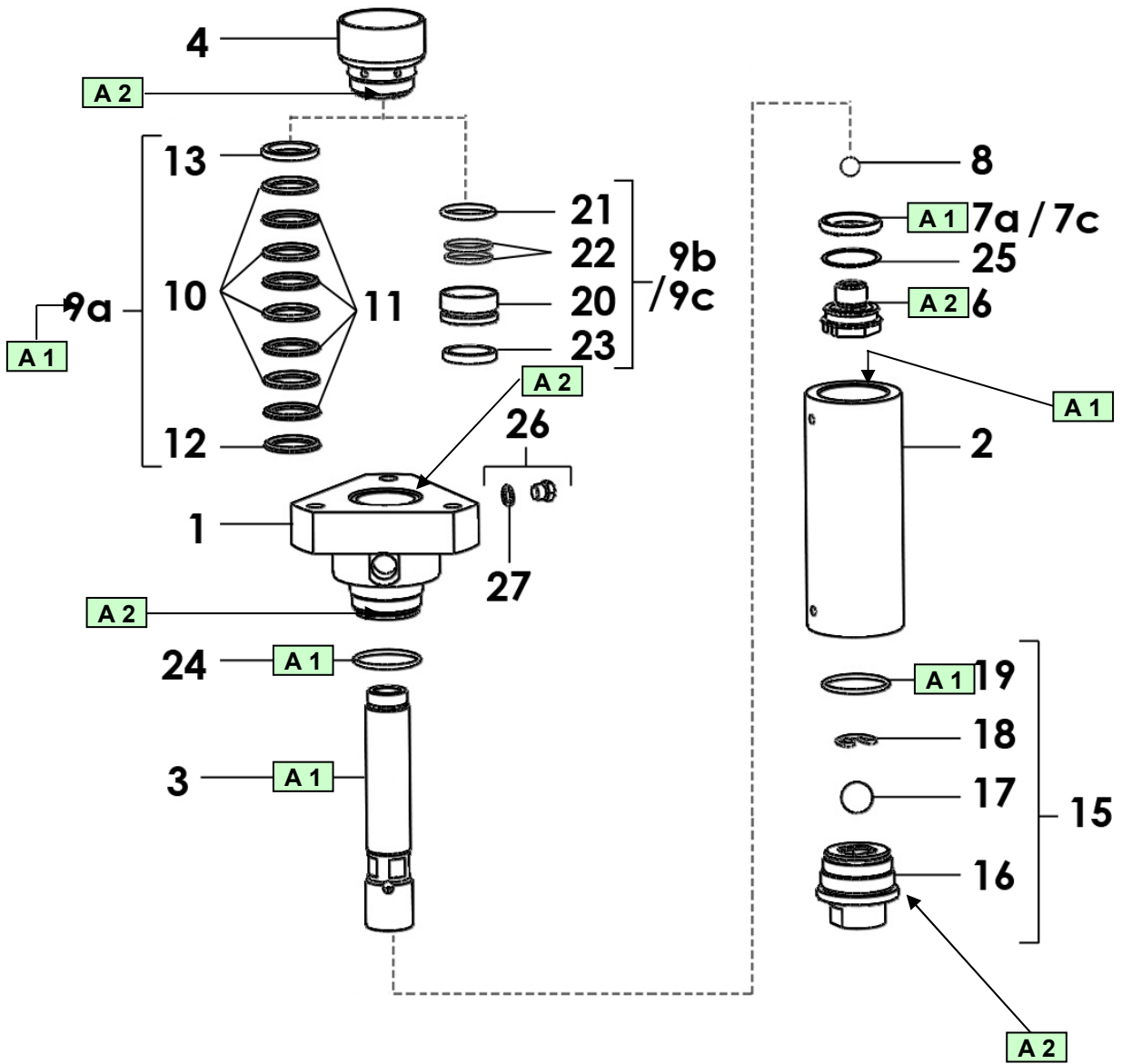

Index	Instruction	Description	Part number
A 1	PTFE grease	'TECHNILUB' grease (10 ml / 0.34 oz)	560.440.101
A 2	Anti-seize grease	Grease box (450 g / 1 lb)	560.420.005

■ FLUID SECTION, MODEL F260 (CATALYST) (REFER TO DOC. 573.409.050)

**Guards (air motor cover, coupling shields, housings ...) have been designed for safe use of the equipment.
The manufacturer will not be held responsible for bodily injury or failure and / or damage to property due to removal or partial removal of the guards.**

1 - FLUID SECTION REPLACEMENT

To remove a component of the pump :

- Disassemble all the accessories of the pump (rods, filter), if it necessary.
- Put aside the pump, if it is necessary (the pump is fitted with an hoisting ring).

Before removing the B sub-assembly or the A sub-assembly, you must remove the connecting rod (41). For that :

- Unscrew the nut fitting (38) and the screws (43 & 45),
- Remove the connecting rod (41).

The fluid section of the pump consists of 2 sub-assemblies :

- the upper part (bellows suction sub-assembly : A)

- the lower part (fluid sub-assembly : B)

This sub-assembly is more frequently service than the A sub-assembly.

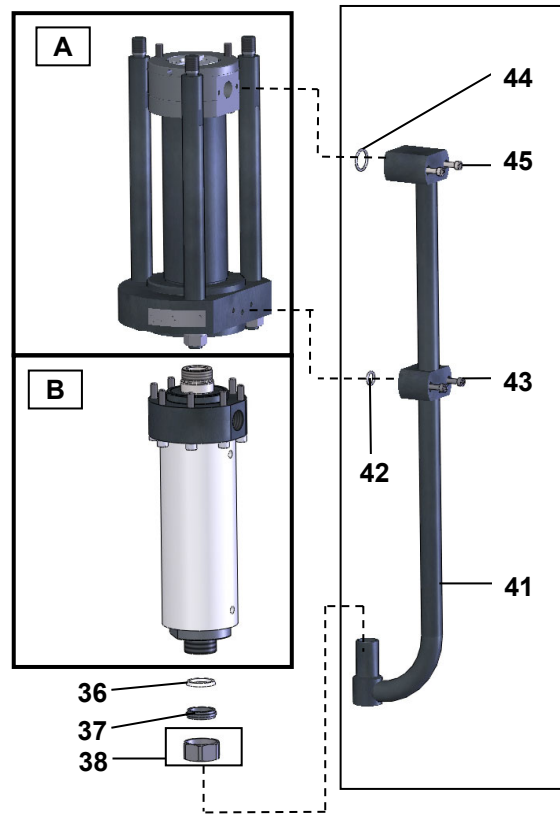

2 - DISASSEMBLY / REASSEMBLY OF THE FLUID SECTION

DISASSEMBLY / REASSEMBLY OF THE FLUID SUB-ASSEMBLY (B)

Nota : The suction valve, the cylinder, the exhaust valve and the upper GT-seal are dismantled and change without needing to separate the fluid sub-assembly (B) from the suction sub-assembly (A).

Suction valve (30)

Disassembly

Unscrew the suction valve (30).

Nota : If the cylinder (21) remains attached to the suction valve, unscrew both parts, then hold cylinder (21) by inserting a rod into the cylinder holes designed for this purpose.

The ball (32) is secured on the valve (31) by means of a circlips (33).

Clean the parts with the appropriate cleaning solvent.

Assembly

Reinstall the ball (32) and the circlips (33) on the suction valve body (31).

Change the seal (13). Lubricate it.

⚠ Lubricate the threading of the valve body.

Reinstall valve assembly (30) on the cylinder (21).

Cylinder (21)

In order to make easier the disassembly, a hole is drilled in the cylinder (21) at each end.

Depending on the part that it is unscrewed first, insert a rod into one of these holes to unscrew the other part.

When reassembling, make sure the two seals (13) are installed. Lubricate them.

⚠ Lubricate the inside of the cylinder (grease, type A1) and the tappings to prevent from damaging the mobile packing (grease, type A2) (refer to assembly instructions §).

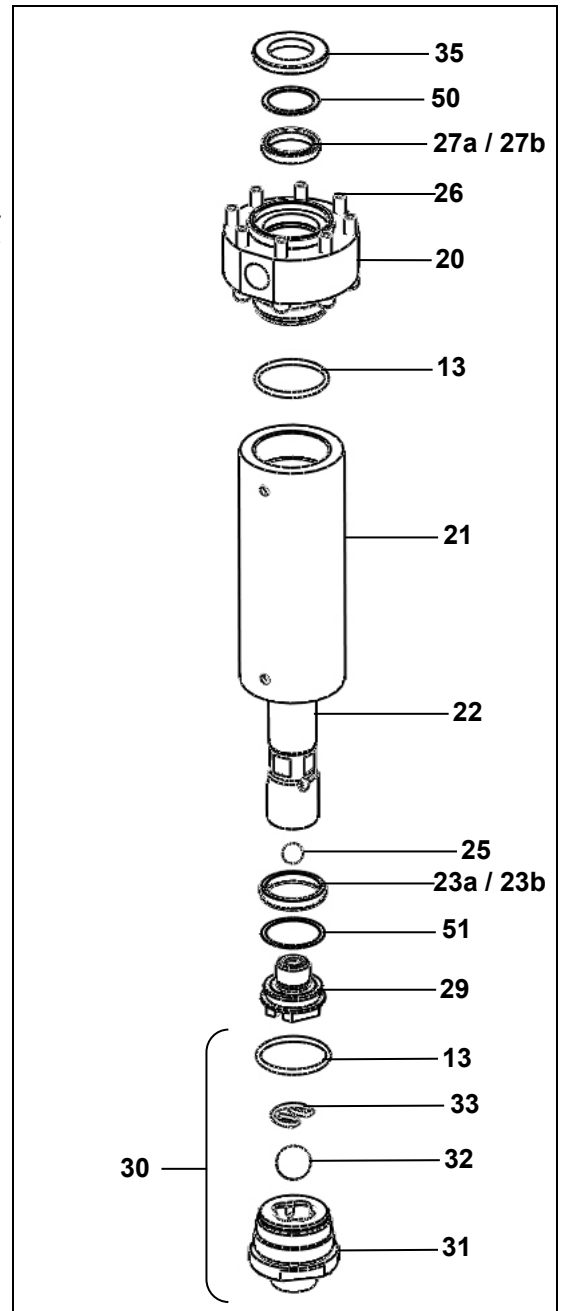

Exhaust valve (29) and mobile packing (23)

Disassembly

Unscrew the cylinder (21) and pull it downwards.
Unscrew the exhaust valve (29) with a flat wrench n° 46 by holding the piston (22).
Remove the ball (28), the washer (6c) and the mobile packing (seal - 23a/23b).
Clean the parts.

Assembly

Install a new seal (23a/23b). Lubricate it.
➤ **Comply with the seal (23a/23b) installation order.**
Install the ball (25) on the exhaust valve (29).

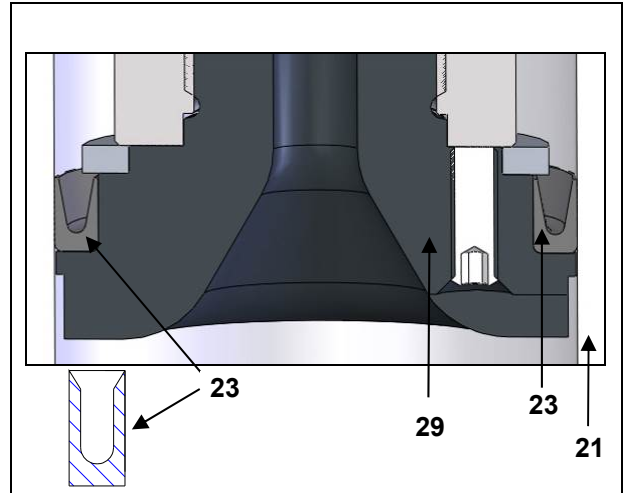

⚠ Lubricate the threading of the exhaust valve (grease, type A2).
Screw the whole on the piston lower part (22).

DISASSEMBLY / ASSEMBLY OF THE BELLOWS SUCTION SUB-ASSEMBLY (A)

Nota : The disassembling of the upper tightness seal and of the bellows requires to separate the fluid sub-assembly (B) from the suction sub-assembly (A).

SEPARATION PROCEDURE

Disassemble the cylinder (21). You can see the fluid section piston (22).

➤ You must place the piston downwards. ⚠ install an air pressure (from 0.2 to 0.5 bar / from 2.9 to 7.2 psi) on the air motor to make the piston (22) get down. When the piston is at its lower point, close the air inlet valve to prevent the piston from getting up.

Remove the 3 nuts (11), the washers (12).

Pull the suction flange (1) downwards, you can see the skirt (6).

Nota: The cylinder (2) must keep assemble with the suction bearing (3).

Unscrew slightly the 3 screws (9) to give play on the bellows (5).

Unscrew the skirt (6) (tools : 41 mm / 1.6" wrench).

Nota : To make easier the disassembly of the skirt, you can remove one of the 3 pump tie-rods (7).

⚠ **Caution : the skirt must be visible.**

By means of the 2 wrenches, to separate the piston (22) from the motor rod (40M) by using the flats on the motor rod and those on the base of the piston.

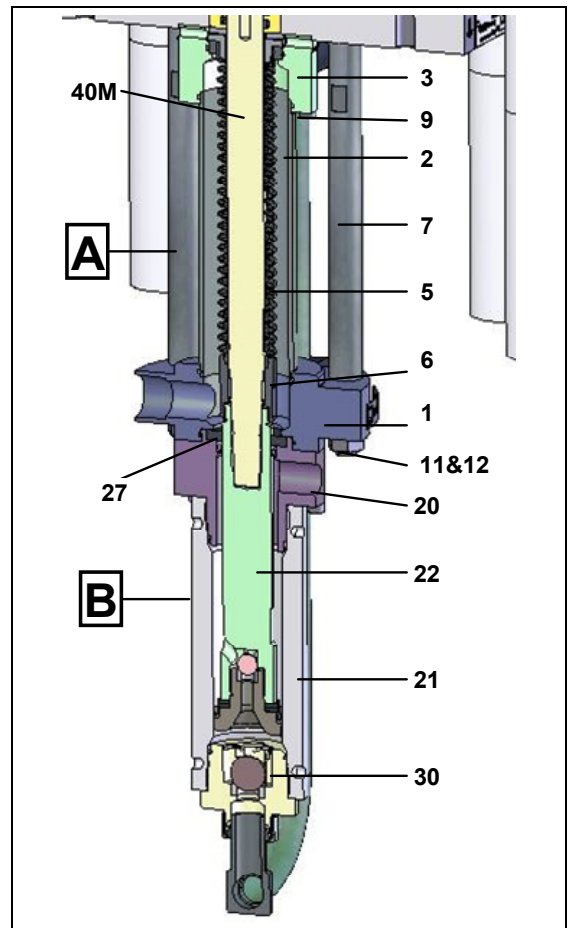

COUPLING PROCEDURE

 Change the seals (8 & 24) and lubricate them.

Clean the threading of the motor rod (40M) and the tapping of the pump piston (22).
Make the air motor rod get down (see the previous paragraph) .

 **Apply a light coating glue to the threading of the motor rod (Loctite 222).**

Place the exhaust flange-fluid section piston assembly.

Screw the motor rod into the fluid section.

 **Apply a light coating of glue to the pump piston threading (Loctite 5772).**

➤ **Pull the skirt (6) downwards, then screw it on the fluid section piston (22).**
(tool : 41 mm / 1.6" wrench).

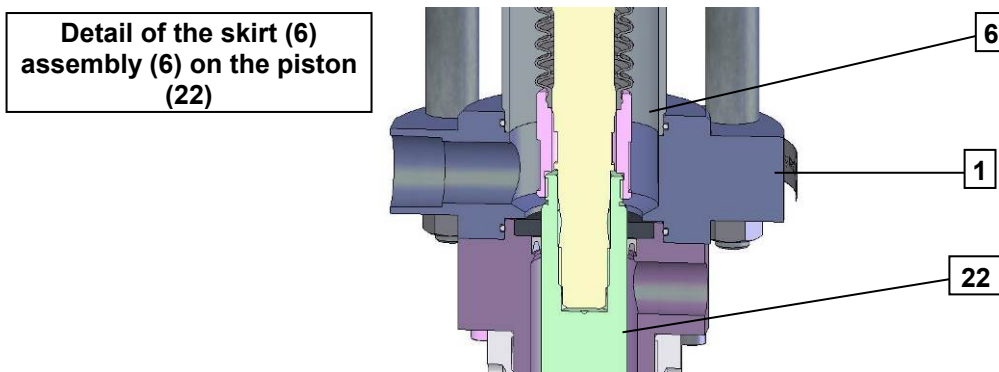

Reinstall the tie-rod (7) if you removed it.

Reinstall the suction flange (1).

Tighten the 3 screws (9).

Place the 3 washers and tighten the nuts (11).

Reinstall the lower part of the pump (cylinder, suction valve, suction rod,...) in the reverse order of the disassembly sequence, as explained previously.

Upper tightness seal (27a/27b)

Disassembly

Unscrew the 8 screws (26).

Separate the fluid sub-assembly (A) from the suction sub-assembly (B).

Remove the upper ring (35).

Remove the seal (27a/27b) by pulling the exhaust flange (20) downwards.

Remove the o-ring seals (8 & 24) which are on the suction flange.

Assembly

 Place the seal (27a/27b) in the exhaust flange (20) after having lubricated it.

➤ **Comply with the seal (27) installation order.**

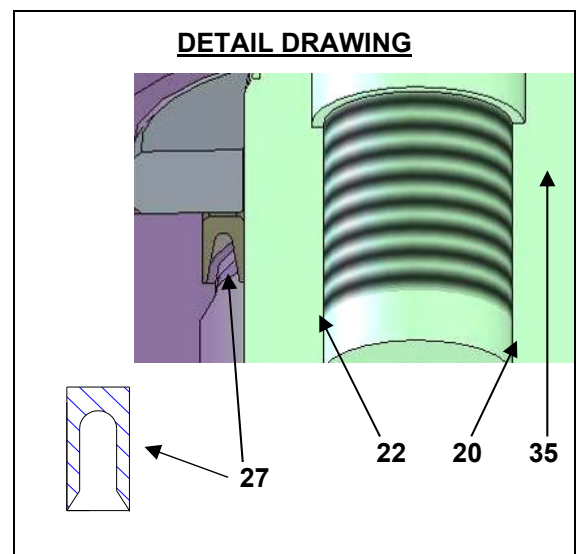

Place the upper part of the piston (22) on the cone shaped tool (refer to above drawing).

 Grease the cone shaped tool.

Slide the piston-cone shaped tool into the exhaust flange (20), from downwards to upwards.

Slide the GT seal on the whole (the tool prevents from damaging the seal when assembling the piston).

Remove the tool when it is above the flange (20).

Install the upper ring (35).

Change the seal (8) and tighten the 8 screws (26)

Couple the fluid sub-assembly (B) with the suction sub-assembly (A).



Bellows

This operation must be done after the separation of the lower part from the upper part of the fluid section and after the dismounting of the upper tightness seal.

In the work table, prepare assembly, which consists of fluid section piston-exhaust flange while following the procedure of the upper tightness seal (27).

Disassembly

Remove the bearing (3) from the cylinder (2).

Separate the suction bearing (3) from the motor by removing the screws (9).

Slide, then put aside the bellows-skirt-flange assembly.

Remove the bellows flange (4) to take off the upper part of the bellows.

Dismount the skirt (6).

Assembly

To prepare an assembly, which consists of bellows-skirt-flange, you must :

- Install a new bellows (5) into the bellows flange (4).
- Change the seal (13).

 Lubricate the seal (13) and the flange (4) (grease, type A1).

- Insert the assembly in the bearing (3).
- When installing the bellows, push it into skirt (6) firmly.
- Install the upper bellows flange (14).

Slide the bellows-skirt-flange assembly along the air motor rod.

Orientate it and tighten it on the air motor base by means of the 3 screws (9).

Nota : To make easier the assembly, you can remove one of the 3 pump tie-rods (7).

Couple the fluid sub-assembly (B) with the suction sub-assembly (A).

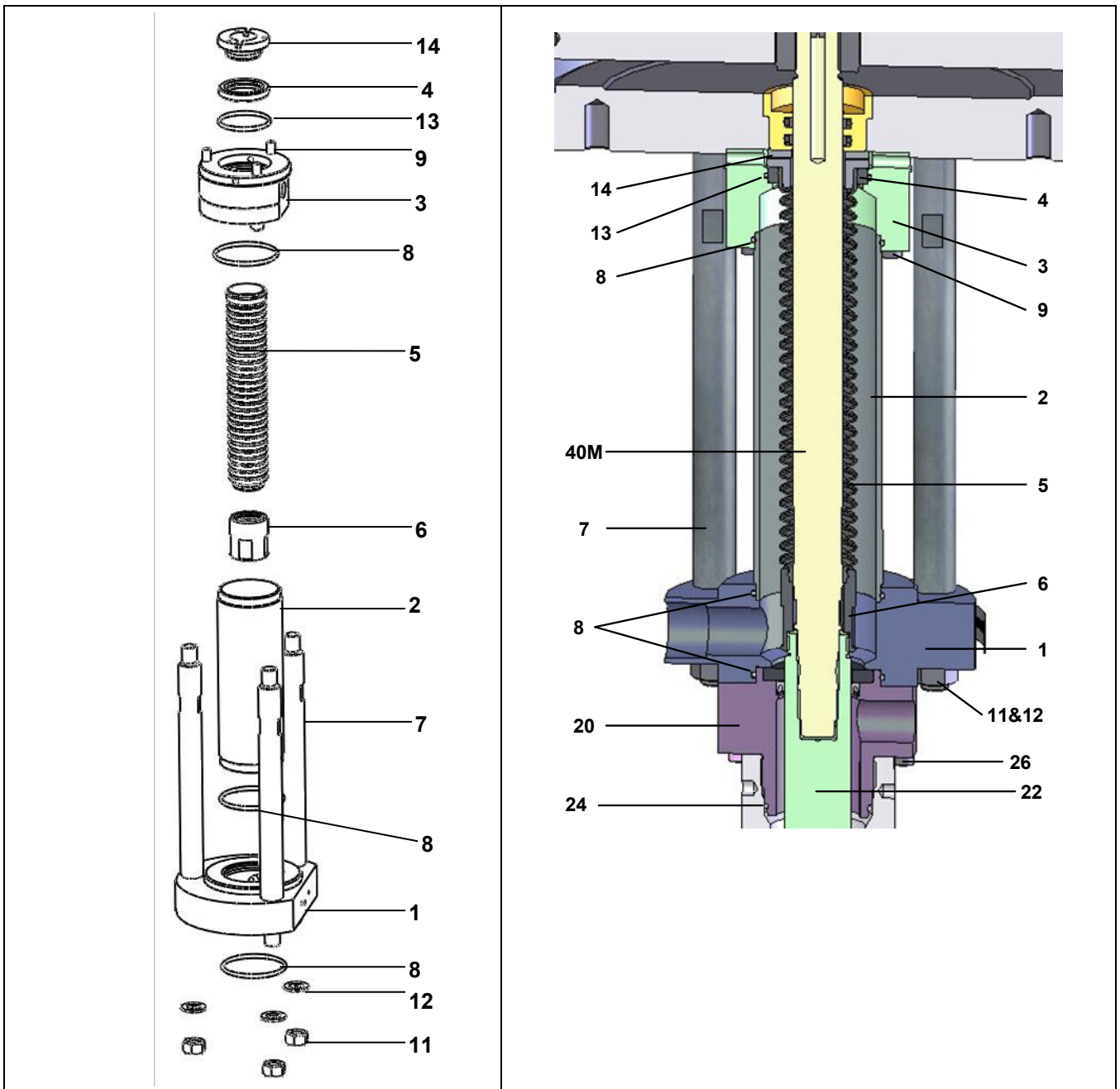

Before reassembling the different components :

- Clean the parts with the appropriate cleaning solvent,
- Install new seals if it is necessary, after having lubricated them with PTFE grease,
- Lubricate the piston and the inside of the cylinder to prevent from damaging the seals,
- Install new parts if it is necessary.

ASSEMBLY INSTRUCTIONS (FLUID SECTION, MODEL F260)

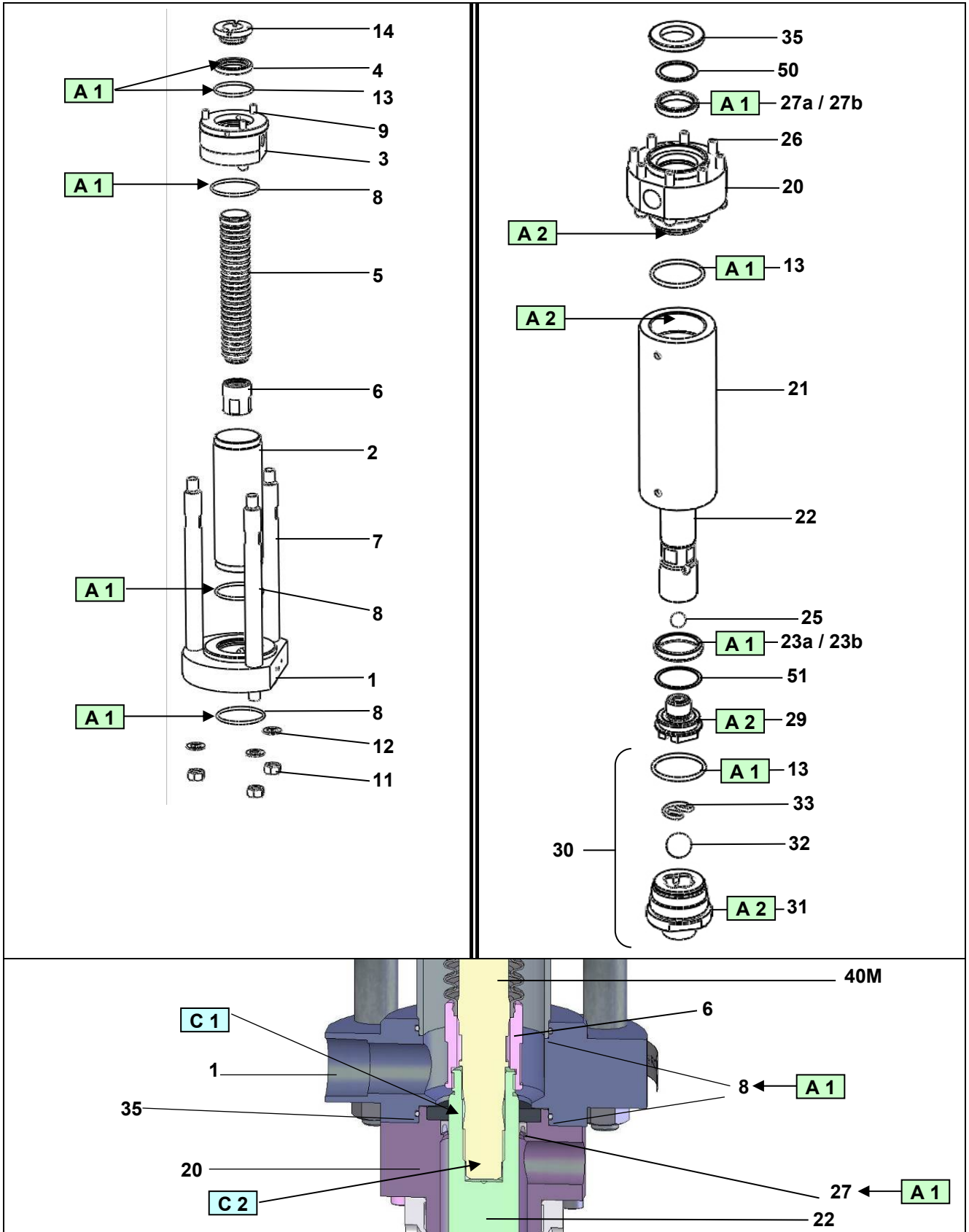

Index	Instruction	Description	Part number
A 1	PTFE grease	'TECHNILUB' grease (10 ml / 0.34 oz)	560.440.101
A 2	Anti-seize grease	Grease box (450 g / 1 lb)	560.420.005
C 1	Medium strength Aneorobic Pipe sealant	Loctite 5772 (50 ml / 1.7 oz)	554.180.015
C 2	Low strength - Aneorobic Adhesive	Loctite 222 (50 ml / 1.7 oz)	554.180.010

<p>Doc. 573.386.050 Date/Datum/Fecha : 24/03/22 Annule/Cancela/ Ersetzt/Anula : 09/10/20</p>	<p>Modif. / Änderung : Mise à jour / Update / Aktualisierung / Actualización</p>	<p>Pièces de rechange Spare parts list Ersatzteilliste Piezas de repuesto</p>
--	---	--

MACHINE DE DOSAGE ELECTRONIQUE - ELECTRONIC DOSING MACHINE
ELEKTRONISCHE 2K-ANLAGE - MÁQUINA DE DOSIFICACIÓN ELECTRÓNICA

PU 3000 AIRMIX® # 155.680.110

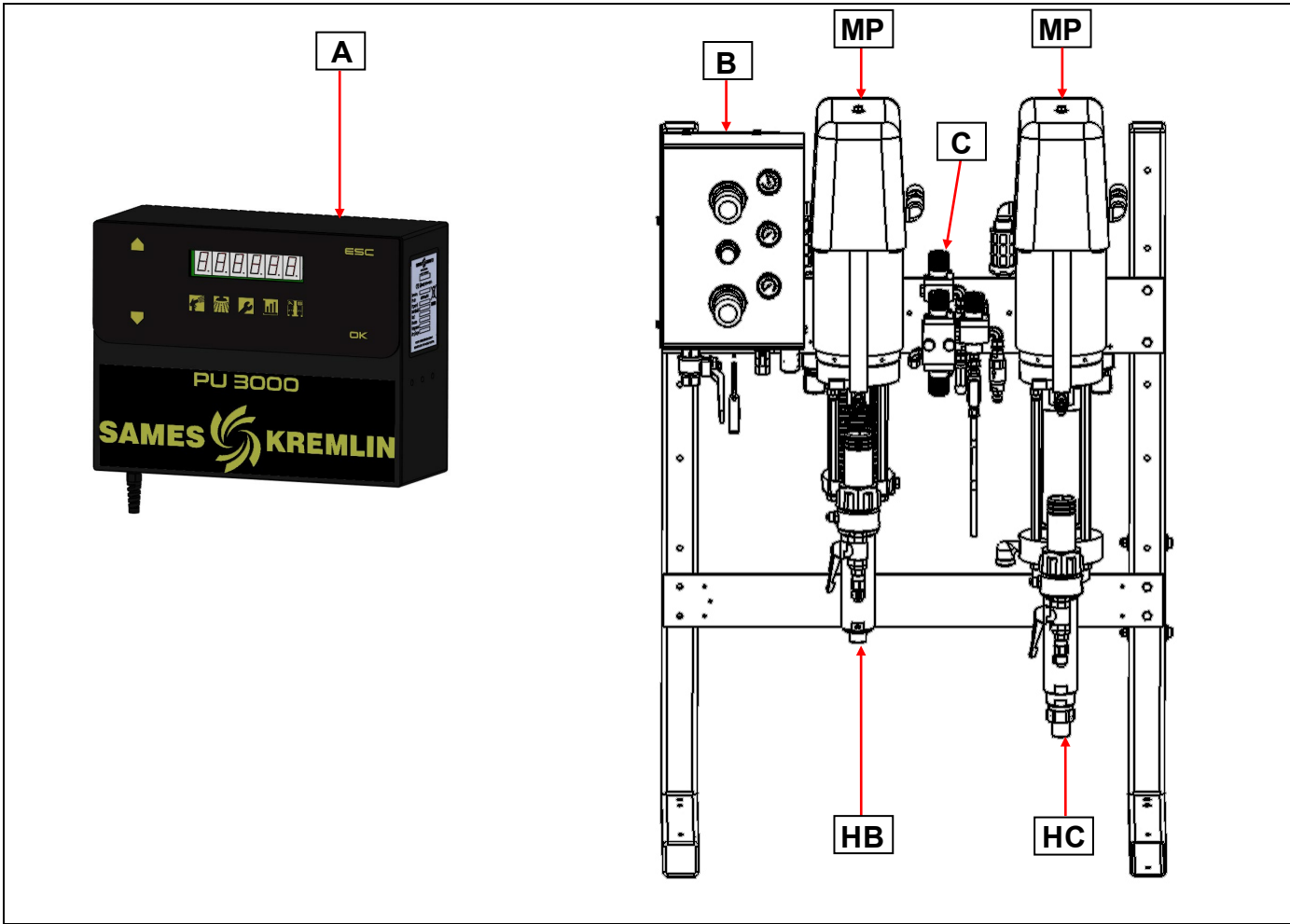

<p>MP Moteur pneumatique / Air motor Luftmotor / Motor neumático</p>	<p>HB Hydraulique Base / Base fluid section Basis-Hydraulikteil / Hidráulica Base</p>	<p>HC Hydraulique Catalyseur / Catalyst fluid section / Härter-Hydraulikteil / Hidráulica Catalizador</p>
3000 PU	C100	F100
<p># 155.680.045 (📄 Doc. 573.387.050)</p>	<p># 144.960.000 (📄 Doc. 573.080.050)</p>	<p># 144.960.200 (📄 Doc. 573.114.050)</p>

Option / On request / Optionen / Opción :

PS : Pompe de rinçage / Flushing pump / Spülpumpe / Bomba de limpieza

A **COFFRET DE COMMANDE / CONTROL CABINET / STEUERUNGSGEHÄUSE / ARMARIO DE MANDO**
155.680.040

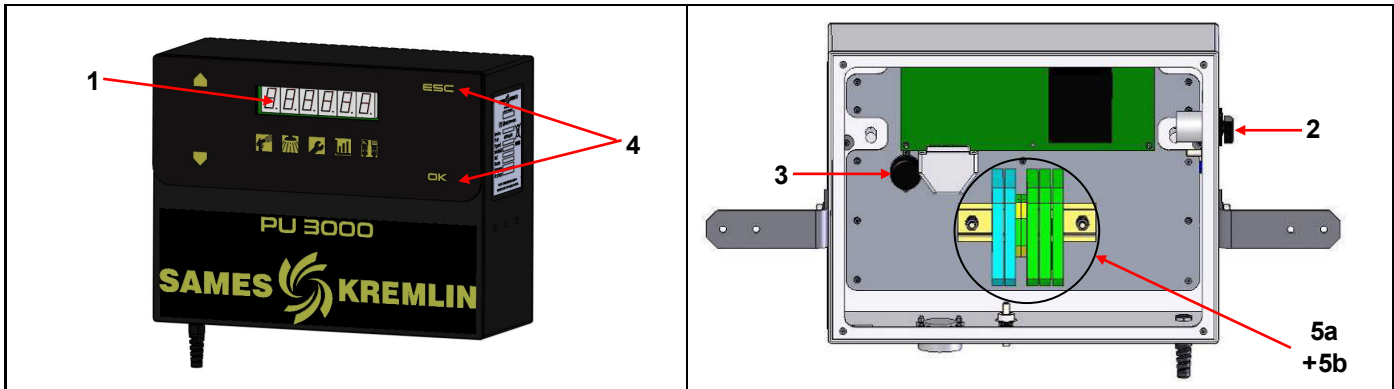

Ind	#	Désignation	Description	Bezeichnung	Denominación	Qté
*1	155 680 048	Carte µ avec afficheur	µ card with display unit	Elektronische Karte mit integriertem Display	Carta µ con visualizador	1
2	901 280 226	Interrupteur	Switch	Schalter	Interruptor	1
3	901 280 193	Buzzer 24V - 100 db	Buzzer 24V - 100 db	Summer 24V - 100 dB	Sirena 24V - 100 db	1
*4	155 660 925	Ensemble capteur et aimant	Sensor and magnet assembly	Sensor und Magnet Einheit	Conjunto captador y imán	4
5a	903 050 530	Barrière Zener Z 728	Z 728 Zener barrier	Zener Barriere Z 728	Barrera Zener, tipo Z 728	3
5b	903 050 531	Barrière Zener Z 764	Z 764 Zener barrier	Zener Barriere Z 764	Barrera Zener, tipo Z 764	2

B **EQUIPEMENT D'AIR / AIR SUPPLY / LUFTAUSTRÜSTUNG / EQUIPO DE AIRE**

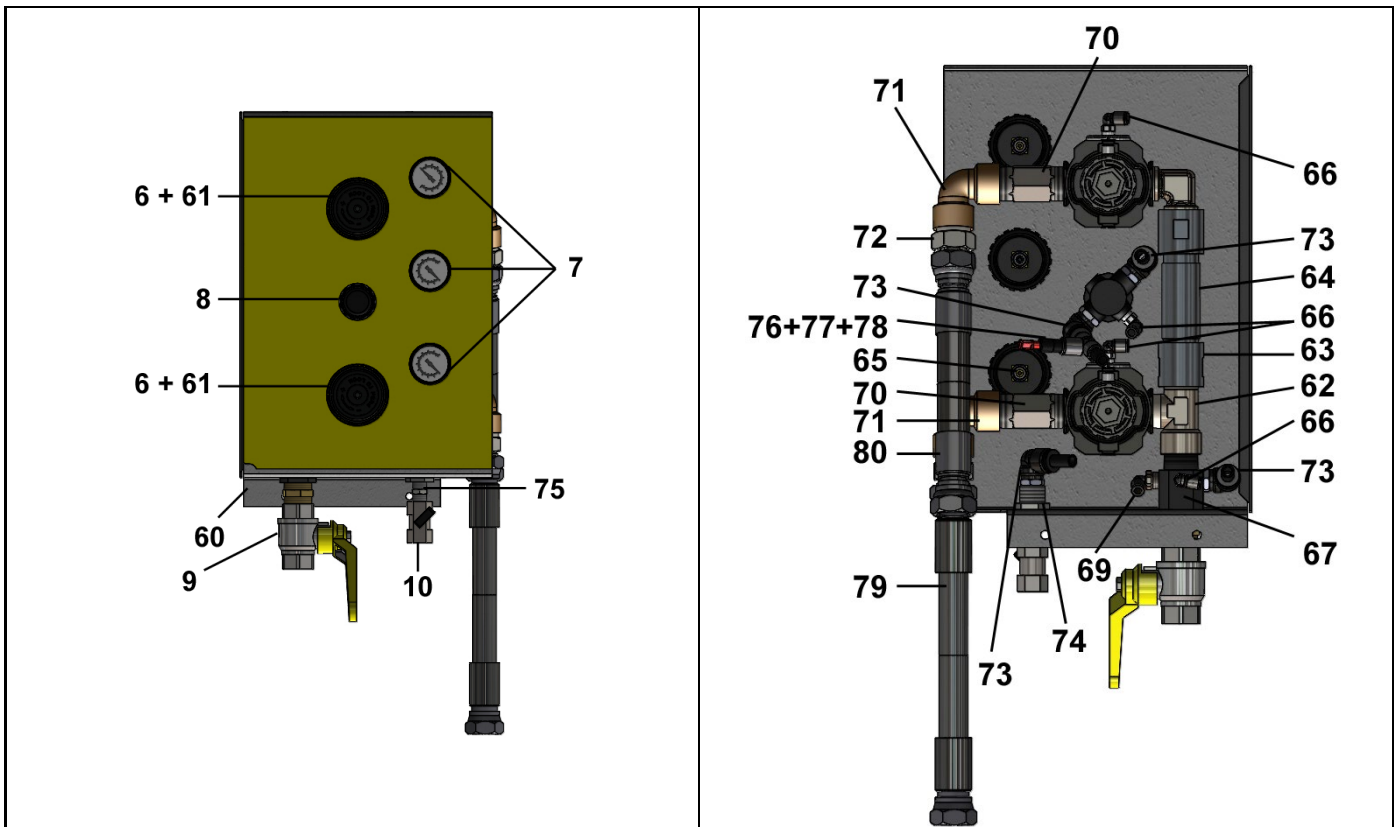

Ind	#	Désignation	Description	Bezeichnung	Denominación	Qté
*6	903 130 517	Régulateur d'air	Air regulator	Druckminderer	Manorreductor de aire	2
*7	910 011 205	Manomètre 0-10 bar	Gauge, 0-10 bar / 0-145 psi	Manometer, 0-10 bar	Manómetro, tipo 0-10 bar	3
*8	91 551	Régulateur d'air	Air regulator	Druckminderer	Manorreductor de aire	1
9	91 458	Vanne FF 3/4" G à décompression	Valve, model FF 3/4" G	Absperrhahn IG 3/4" G	Grifo, tipo HH 3/4" G	1
10	903 090 806	Vanne F 1/4" G	Valve, model F 1/4" G	Absperrhahn IG 1/4" G	Grifo, tipo H 1/4" G	1
60	055 680 013	Support	Support	Halterung	Soporte	1
61	903 130 518	Ecrou de régulateur	Regulator nut	Mutter des Reglers	Tuerca de regulador	2
62	905 121 034	Raccord té MMF conique R 3/4 - G 3/4	MMF conical tee fitting, model R 3/4 - G 3/4	AG/AG/IG T-Verschraubung konisch R 3/4 - G 3/4	Racor te MMH cónico tipo R 3/4 - G 3/4	1
63	055 680 094	Manchon d'adaptation	Sleeve adapter	Adapterhülse	Manguito de adaptación	2
64	055 680 095	Manchette Longueur 90 mm	Sleeve Length 90 mm	Manschette Länge 90 mm	Manga Longitud 90 mm	1
-	NC / NS	Joint FKM noir	FKM seal, black	Dichtung FKM schwarz	Junta FKM negro	2
65	905 120 921	Raccord F G 1/8 - T 4x6	Fitting, model F G 1/8 - T 4x6	Doppelnippel, IG G 1/8 - T 4x6	Racor, tipo H G 1/8 - T 4x6	3
66	905 120 902	Coude G 1/8 - T 4x6	Elbow, model G 1/8 - T 4x6	Winkel G 1/8 - T 4x6	Codo, tipo G 1/8 - T 4x6	4
67	210 005	Nourrice	Distribution block	Verteilerblock	Repartidor	1
68	552 465	Mamelon MM 3/4"	Nipple, model double male 3/4"	Nippel, AG/AG 3/4"	Pivote de centrado, tipo MM 3/4"	1
69	905 270 905	Coude G 1/4 T 4x6	Elbow, model G 1/4 - T 4x6	Winkel G 1/4 - T 4x6	Codo, tipo G 1/4 - T 4x6	1
-	906 333 106	Bouchon 1/8 G	Plug, model 1/8 G	Stopfen, 1/8 G	Tapón, tipo 1/8 G	1
70	055 581 401	Mamelon inox 3/4	Nipple, stainless steel	Nippel, Edelstahl 3/4	Unión, tipo 3/4 de inox	2
71	552 429	Coude FF 3/4"	Elbow, model FF 3/4"	Winkel IG/IG 3/4"	Codo, tipo HH 3/4"	2
72	050 102 634	Raccord MM 3/4 - 3/4 NPS	Fitting, model double male 3/4 - 3/4 NPS	Doppelnippel AG/AG 3/4 - 3/4 NPS	Racor, tipo MM 3/4 - 3/4 NPS	2
73	905 230 002	Coude 1/4 G	Elbow, model 1/4 G	Winkel G 1/4	Codo, tipo 1/4 G	4
74	905 210 301	Traversée de cloison	Separating wall bushing	Trennwand - durchführung	Pasa muros	1
75	050 102 213	Raccord MM 8x13	Fitting, model double male 8x13	Doppelnippe AG/AG 8x13	Racor, tipo MM 8x13	1
-	903 130 604	Ecrou de fixation détenteur	Regulator mounting nut	Befestigungsmutter für den Druckminderer	Tuerca de fijación regulador	1
76	905 120 969	Té égal T 8 x 10	Tee, model T 8 x 10	T-Stück, T 8 x 10	Te, tipo T 8 x 10	1
77	905 120 977	Réduction	Reducer	Reduzienippe	Reducción	1
78	905 120 924	Bouchon	Plug	Stopfen	Tapón	1
79	055 680121	Tuyau d'alimentation Longueur : 1,4m	Supply hose, 1.4m long.	Zuleitungsschlauch Länge: 1,4m	Tubería de alimentación 1,4 de largo	1
80	76 881	Flexible 3/4 BSP Longueur : 0,9m	Hose, model 3/4 BSP 0.9m long	Schlauch 3/4 BSP Länge 0,9m	Tubería, tipo 3/4 BSP 0,9m de largo	1
-	539 280 104	Tuyau PU Ø 7 x 10 Longueur : 10m	PU hose, Ø 7 x 10, 10m long.	Schlauch PU Ø 7 x 10 Länge 10m	Tubería PU Ø 7 x 10 10m de largo	1

Ind	#	Désignation	Description	Bezeichnung	Denominación	Qté
-	NC / NS	Tuyau PU Ø 8 x 10 Longueur : 25m	PU hose, Ø 8 x 10, 25m long.	Schlauch PU Ø 8 x 10 Länge 25m	Tubería PU Ø 8 x 10 25m de largo	1
-	NC / NS	Flexible PU noir	PU hose, black	PU-Schlauch, schwarz	Tubería PU, negra	1

C EQUIPEMENT PRODUIT / MIXING UNIT / MISCHEREINHEIT / PARTE PRODUCTO

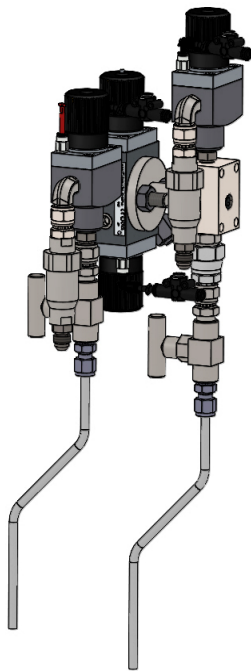

Doc. 573.187.050 & 573.188.050

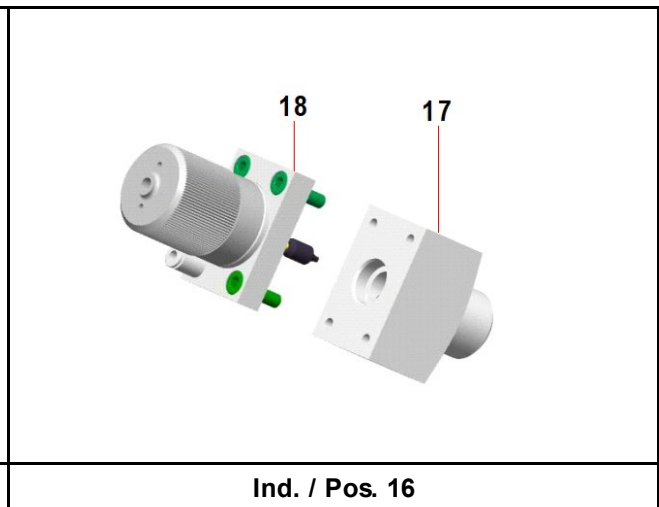
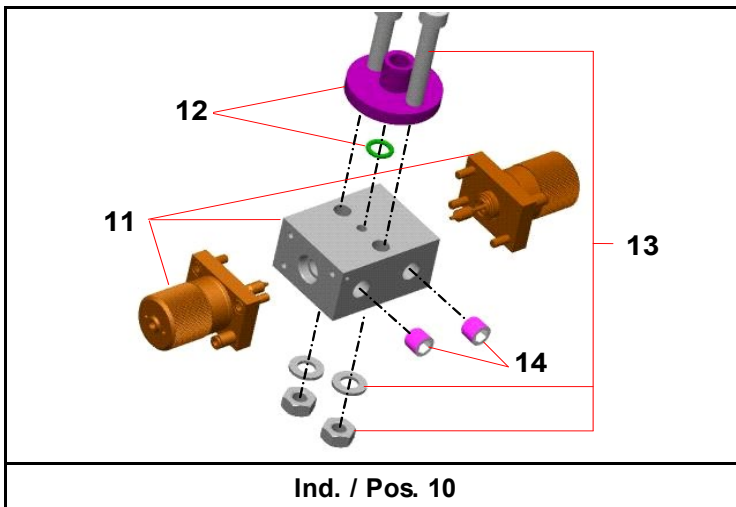
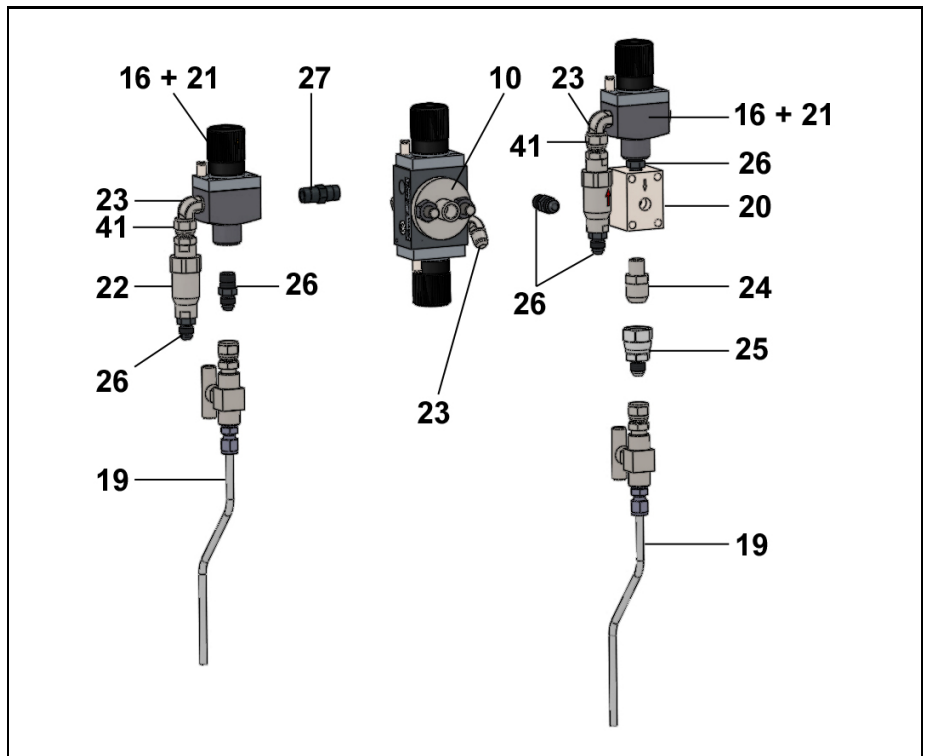

Ind	#	Désignation	Description	Bezeichnung	Denominación	Qté
10	-	Changeur de teintes (Doc. 573.187.050)	Color changer (Doc. 573.187.050)	Farbwechselblock (Dok. 573.187.050)	Cambiador de colores (Doc. 573.187.050)	1
11	155 535 350	▪ Module d'extrémité AIRMIX® GT 200 bar (pour machine dont le numéro de série est > à 15T1003)	▪ GT AIRMIX® end module, model 200 bar/2900 psi (for machine which part number is > to 15T1003)	▪ Unteres Modul GT 200 bar (für Maschine mit der Seriennummer > 15T1003)	▪ Modulo de extremidad AIRMIX® GT 200 bar (para máquina cuyo número de serie es superior a 15T1003)	1
12	155 535 500	▪ Bride de sortie équipée	▪ Outlet flange assembly	▪ Ausgangsflansch, kpl	▪ Brida de salida equipada	1
13	155 535 610	▪ Ensemble 2 tirants	▪ Set of 2 tie-rods	▪ Verindunsbolzen (Satz mit 2 Stück)	▪ Conjunto de 2 tirantes	1
14	906 314 211	▪ Bouchon 1/4" inox	▪ Plug, model 1/4", stainless steel	▪ Blindstopfen 1/4", Edelstahl	▪ Tapón, tipo 1/4" de inox	2
*16	155 528 010	Clapet GT 200 bar	GT valve, 200 bar/2900 psi	Ventil GT 200 bar	Válvula GT 200 bar	2
17	055 528 001	▪ Corps	▪ Body	▪ Körper	▪ Cuerpo	1
*18	155 535 315	▪ Vanne AIRMIX® GT 200 bar (Doc. 573.188.050) (pour machine dont le numéro de série est > à 15T1003)	▪ GT AIRMIX® valve, 200 bar / 2900 psi (Doc. 573.188.050) (for machine which part number is > to 15T1003)	▪ AIRMIX®-Ventil GT 200 bar (Dok. 573.188.050) (für Maschine mit der Seriennummer > 15T1003)	▪ Válvula AIRMIX® GT 200 bar (Doc. 573.188.050) (para máquina cuyo número de serie es superior a 15T1003)	2
*19	155 680 025	Ensemble robinet-pointeau	Needle-valve assembly	Nadelventil-Einheit	Conjunto grifo-válvula	2
20	055 660 070	Bloc d'injection	Injection unit	Injektions-Block	Bloque de inyección	1
21	055 528 002	Bouchon pour clapet	Plug for valve	Blindstopfen für Ventil	Tapón para válvula	1
*22	155 660 120	Clapet AR inox 200 bar	Non return valve, stainless steel, 200 bar / 2900.6 psi	Rückschlagventil, Edelstahl, 200 bar	Válvula AR de inox 200 bar	2
23	905 210 602	Raccord coudé inox (M 1/4 NPT - M 1/2 JIC)	Elbow fitting, stainless steel (double male, 1/4 NPT - # 5 JIC)	Winkelnippel, Edelstahl (AG 1/4 NPT - AG 1/2 JIC)	Racor acodado de inox (M 1/4 NPT - M 1/2 JIC)	3
24	905 210 512	Raccord produit droit M 1/4 G - M 3/4 JIC	Straight fluid fitting (double male, 1/4 NPT - # 8 JIC)	Gewindenippel (AG 1/4 NPT - AG 3/4 JIC)	Racor producto recto (M 1/4 NPT - M 3/4 JIC)	1
25	905 160 219	Raccord tournant inox M 1/2 JIC - F 3/4 JIC	Swivel fitting, stainless steel, model M 1/2 JIC - F 3/4 JIC	Drehanschluss aus Edelstahl AG 1/2 JIC - IG 3/4 JIC	Racor giratorio de inox, tipo M 1/2 JIC - H 3/4 JIC	1
26	550 636	Raccord inox M 1/4 G - M 1/2 JIC	Fitting, stainless steel, model double male, 1/4 G - # 5 JIC	Anschluss, Edelstahl AG 1/4 G - AG 1/2 JIC	Racor de inox, tipo M 1/4 G - M 1/2 JIC	5
27	551 600	Raccord inox MM 1/4"	Fitting, stainless steel, model double male 1/4"	Anschluss aus Edelstahl AG/AG 1/4"	Racor de inox, tipo MM 1/4"	1
41	905 160 218	Raccord tournant inox M 1/4 G - F 1/2 JIC	Swivel fitting, stainless steel, model M 1/4 G - F 1/2 JIC	Drehanschluss aus Edelstahl AG 1/4 G - IG 1/2 JIC	Racor giratorio de inox, tipo M 1/4 G - H 1/2 JIC	2

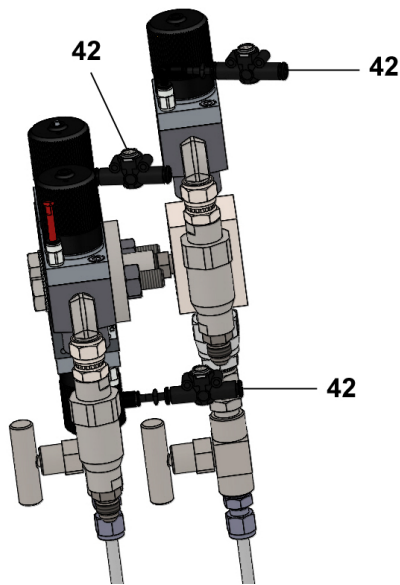

Ind	#	Désignation	Description	Bezeichnung	Denominación	Qté
42	155 680 085	Clapet AR Ø 4	Non-return valve, Ø 4	Rückschlagventil, Ø 4	Válvula AR Ø 4	3

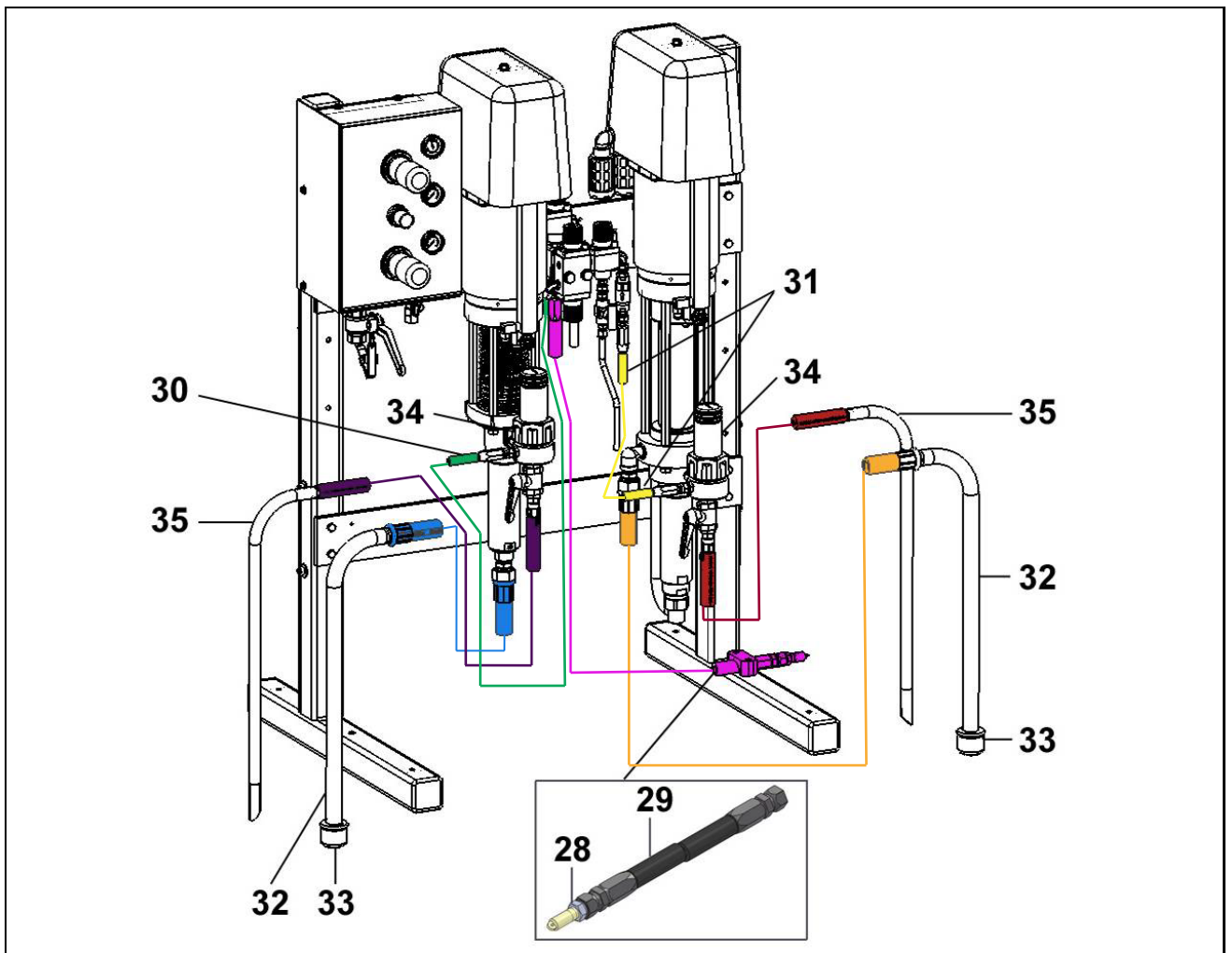

Ind	#	Désignation	Description	Bezeichnung	Denominación	Qté
28	906 314 217	Raccord inox M 3/4 JIC - M 1/2 JIC	Fitting, stainless steel, model double male, # 8 JIC - # 5 JIC	Anschluss aus Edelstahl, AG 3/4 JIC - AG 1/2 JIC	Racor de inox, tipo M 3/4 JIC - M 1/2 JIC	1
*29	155 660 080	Ensemble mélangeur souple (1m - 375 bar)	Flexible mixer assembly (1 m - 375 bar / 5440 psi)	Mischer-Schlauch mit Anschlüssen (1m - 375 bar)	Conjunto mezclador flexible (1m - 375 bar)	1

Ind	#	Désignation	Description	Bezeichnung	Denominación	Qté
*30	050 450 102	Tuyau produit (Ø 6,35 mm, long. 1 m, raccord acier traité, 240 bar)	Fluid hose (6.35 mm / 0.25" dia, 1 m / 3.28 ft long, treated steel hose, 240 bar / 3481 psi)	Materialschlauch (Ø 6,35 mm, Länge. 1 m, Anschluss aus behandeltem Stahl, 240 bar)	Tubería producto (Ø 6,35 mm, 1 m de largo, racor de acero tratado, 240 bar)	1
*31	050 452 001	Tuyau CATA (PTFE, Ø 6,35 mm, long. 1 m, 250 bar)	CATA hose (PTFE, 6.35 mm / 0.25" dia, 1 m / 3.28ft long, 250 bar / 3625 psi)	Härter Schlauch (PTFE, Ø 6,35 mm, Länge 1 m, 250 bar)	Tubería CATA (PTFE, Ø 6,35 mm, 1 m de largo, 250 bar)	1
32	149 596 150	Canne d'aspiration Ø 25	Suction rod Ø 25	Saugschlauch Ø 25	Caña de aspiración Ø 25	2
*33	149 596 152	▪ Crépine Ø 25	▪ Strainer Ø 25	▪ Siebkorb Ø 25	▪ Piña Ø 25	2
34	155 580 400	Filtre AIRLESS® inox 3/8 (Doc. 573.299.050)	AIRLESS filter model 3/8, stainless steel (Doc. 573.299.050)	AIRLESS® Filter 3/8, Edelstahl (Dok. 573.299.050)	Filtro AIRLESS® de inox, tipo 3/8 (Doc. 573.299.050)	2
35	049 596 000	Canne de purge inox	Drain rod, stainless steel	Entleerungsschlauch, Edelstahl	Caña de purga de inox	2
-	910 090 101	Eprouvette (2 litres)	Beaker (2 liters / 0.53 US gal)	Messzylinder (2 Liter)	Probeta (2 litros)	2

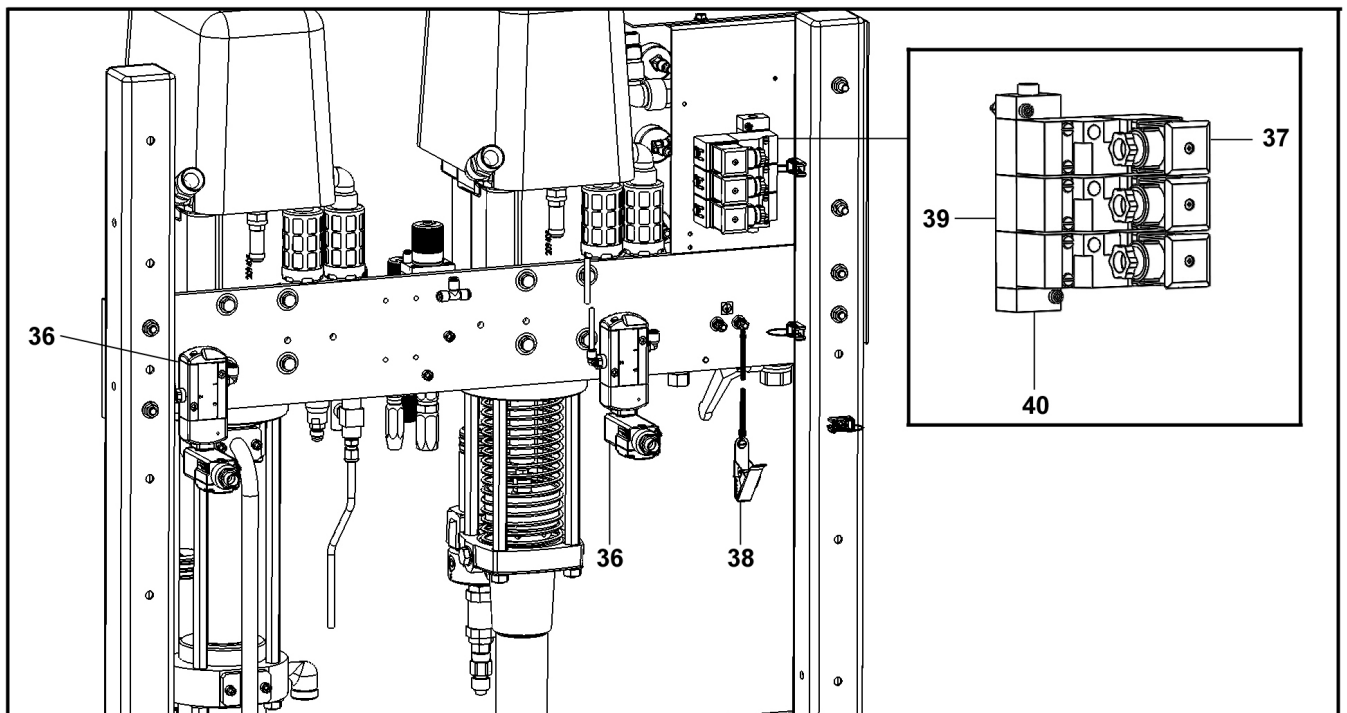

Ind	#	Désignation	Description	Bezeichnung	Denominación	Qté
36	055 660 074	Electrovannes ATEX 24V	Electrovalves, ATEX 24V	Elektroventile, ATEX 24V	Electroválvulas ATEX 24V	2
37	903 050 529	Electrovannes ATEX	ATEX electrovalves	ATEX Elektroventile	Electroválvulas ATEX	3
38	901 180 024	Câble de mise à la terre (Lg. 5m) avec rondelle et vis	Cable ground (5 m / 197" length) with washer and screw	Erdungskabel (5 m) mit scheibe und Schraube	Cable de puesta a tierra (5m de largo) con arandela y tornillo	1
39	903 050 517	Embase	Base	Grundplatte	Base	1
40	903 050 518	Embase	Base	Grundplatte	Base	1

ACCESSOIRES - ACCESSORIES - ZUBEHÖR - ACCESORIOS

Ind	#	Désignation	Description	Bezeichnung	Denominación	Qté
-	149 990 020	Flacon de lubrifiant T (125 ml)	T lubricant (125 ml / 4.4 oz)	Spülmittel "T" (125 ml)	Recipiente de lubricante T (125 ml)	1
-	044 950 008	Clé pour cuve presse-garniture	Wrench for wetting-cup	Schlüssel für Spülmitteltasse	Llave para prensa-estopa	1



OPTION - ON REQUEST - OPTIONEN - OPCIÓN

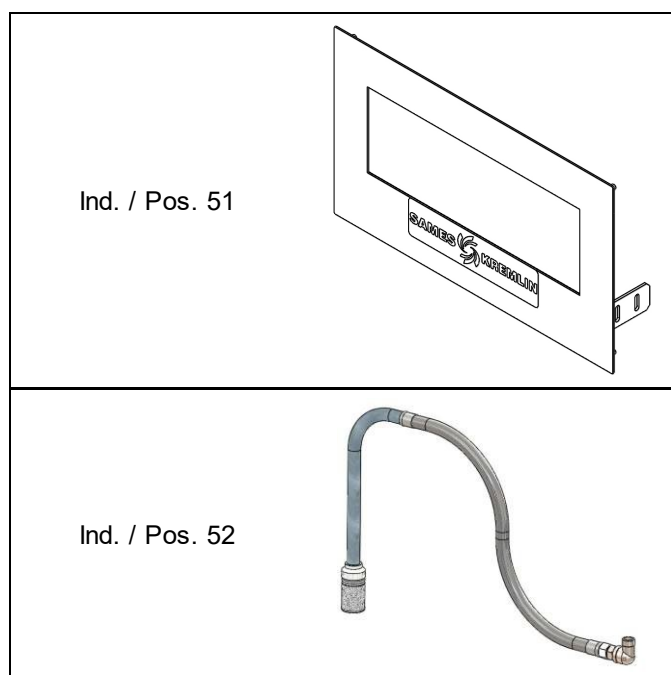
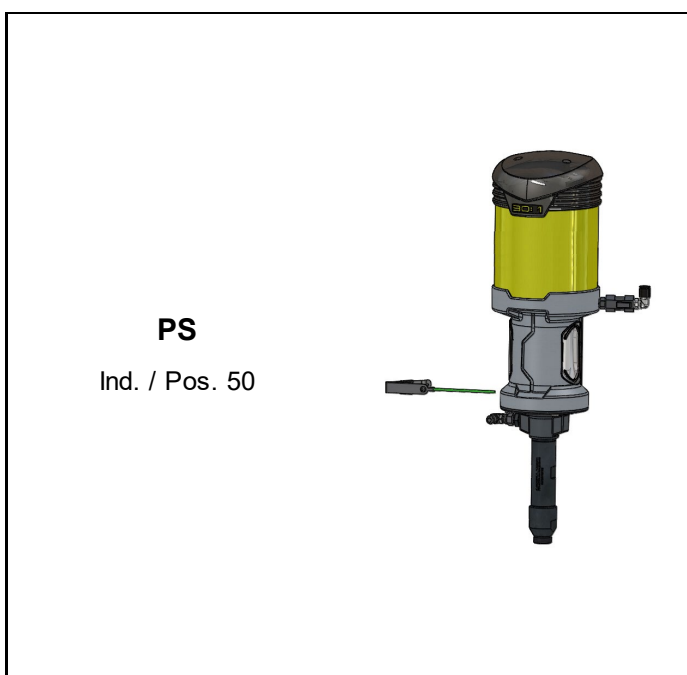

Ind	#	Désignation	Description	Bezeichnung	Denominación	Qté
50	151 145 090	Pompe de rinçage pour pompe PU 3000, modèle 30-C25 (Doc. 573.438.050)	Flushing pump for PU 3000 pump, model 30-C25 (Doc. 573.438.050)	Spülpumpe für 2-K-Anlage PU 3000, Modell 30-C25 (Dok. 573.438.050)	Bomba de limpieza para bomba PU 3000, tipo 30-C25 (Doc. 573.438.050)	1
51	155 660 340	Kit commande en cabine	Booth control kit	Set für Kabinensteuerung	Kit mando en cabina	1
52	149 597 101	Kit canne d'aspiration 1"	Suction rod kit, model 1"	Saugschlauch 1"	Kit caña de aspiración 1"	1
-	149 990 020	Flacon de lubrifiant T (125 ml)	T lubricant (125 ml / 4.4 oz)	Spülmittel « T » (125 ml)	Recipiente de lubricante T (125 ml)	1

* Pièces de maintenance préconisées.
 * Preceding the index number denotes a suggested spare part.
 * Bezeichnete Teile sind empfohlene Ersatzteile.
 * Piezas de mantenimiento preventivas.

N C : Non commercialisé.
 N S : Denotes parts are not serviceable.
 N S : Bezeichnete Teile gibt es nicht einzeln, sondern nur komplett.
 N S : no suministrado.

Doc. 573.387.050
 Date/Datum/Fecha : 14/11/19
 Annule/Cancel/
 Ersetzt/Anula : 16/01/14

Modif. / Änderung :
 Mise à jour / Update / Aktualisierung
 / Actualización

Pièces de rechange
Spare parts list
Ersatzteilliste
Piezas de repuesto

PU 3000 : MOTEUR A AIR / AIR MOTOR / LUFTMOTOR / MOTOR DE AIRE

Mod. 3000 # 155.680.045

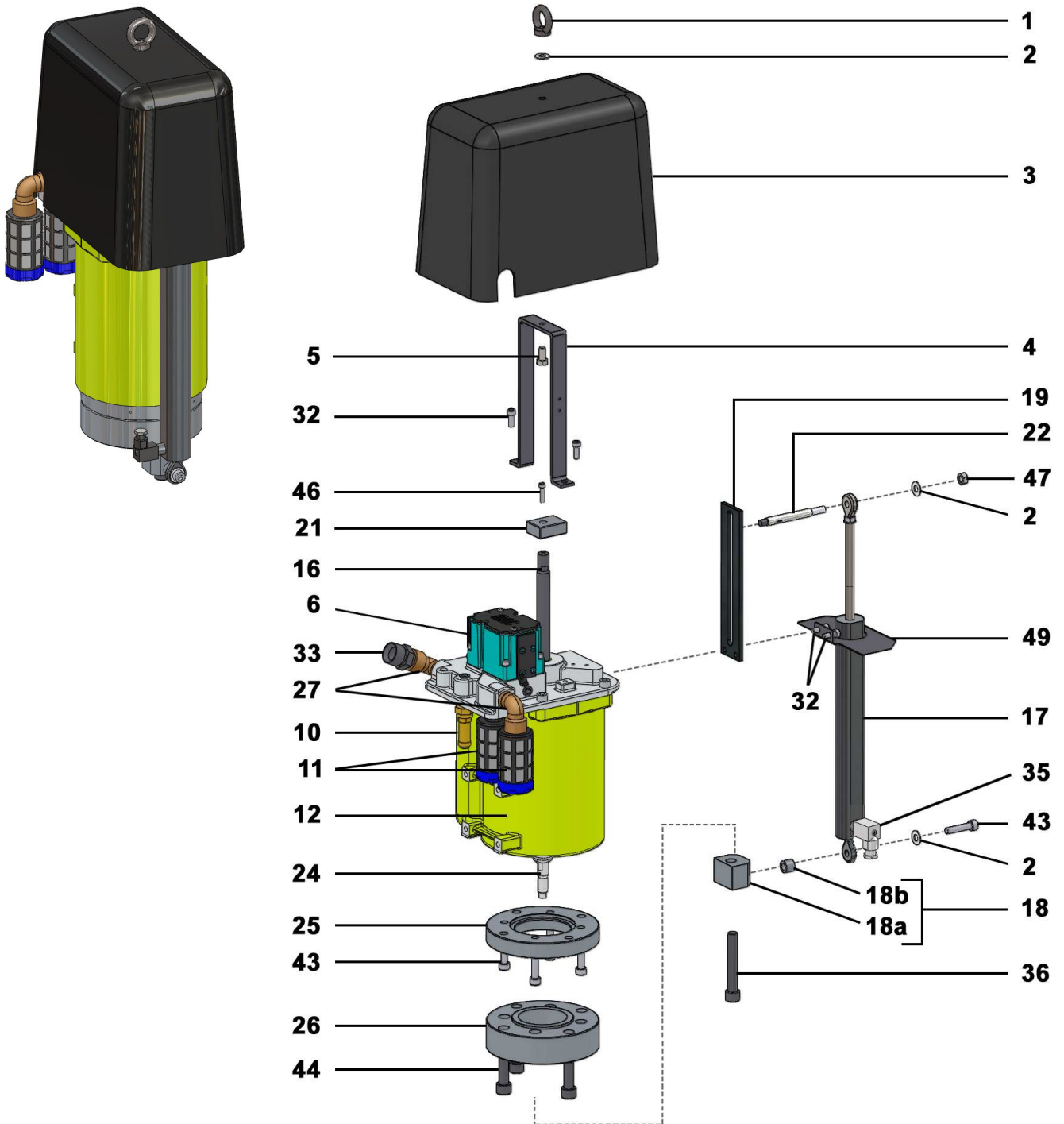

Détails - Details - Einzelheiten - Detalles

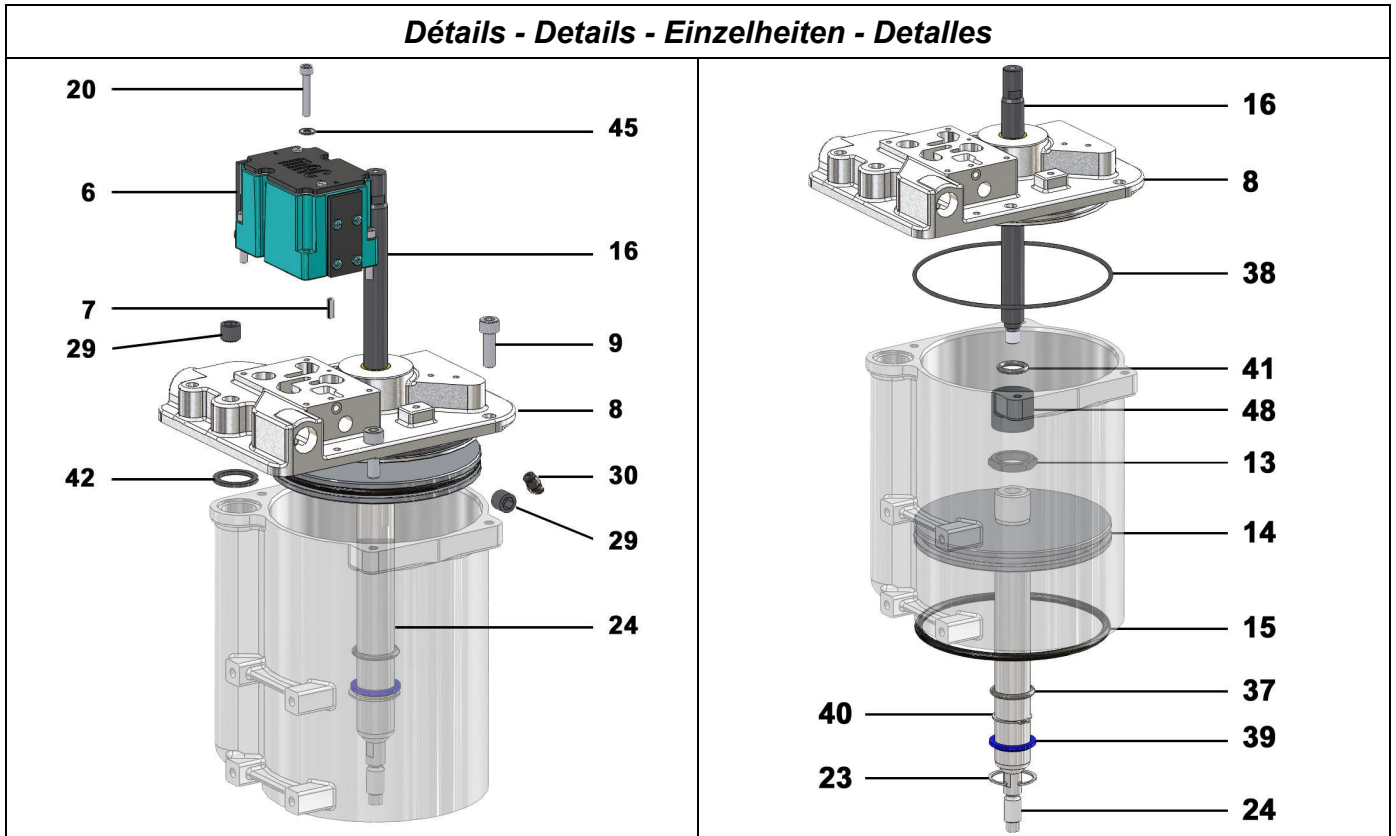

Ind	#	Désignation	Description	Bezeichnung	Denominación	Qté
1	91 421	Anneau de levage	Hoisting ring	Ringsschraube	Anillo de sujeción	1
2	963 040 019	Rondelle MU 8	Washer, model MU 8	Scheibe, MU 8	Arandela, tipo MU 8	3
3	NC / NS	Capot	Cover	Haube	Capó	1
4	210 286	Etrier	U-Bolt	Halterung	Tirante	1
5	NC / NS	Vis HM 8 x 16	Screw, model HM 8 x 16	Schraube, HM 8 x 16	Tornillo, tipo HM 8 x 16	1
*6	146 310 092	Distributeur 4/2	Distributor, model 4/2	4/2 Wege Pneum. Ventil	Distribuidor, tipo 4/2	1
7	NC / NS	Goupille	Pin	Splint	Pasador	1
8	NC / NS	Couvercle	Cover	Deckel	Tapa	1
9	88 152	Vis CHc M 8 x 25	Screw, model CHc M 8 x 25	Schraube, CHc M 8 x 25	Tornillo, tipo CHc M 8 x 25	4
*10	903 080 401	Soupape de sécurité	Safety valve	Sicherheitsventil	Válvula de seguridad	1
*11	146 310 091	Silencieux	Muffler	Schalldämpfer	Silenciador	2
12	209 405	Cylindre	Cylinder	Zylinder	Cilindro	1
13	210 442	Ecrou	Nut	Mutter	Tuerca	1
*14	209 407	Piston	Piston	Kolben	Pistón	1
15	NC / NS	Joint torique (piston)	O-Ring (piston)	O-Ring Dichtung (Kolben)	Junta tórica (pistón)	1
16	210 443	Tige d'inversion	Reversing rod	Umsteuerstange	Eje de inversión	1
*17	91 519	Capteur de déplacement	Movement sensor	Linearpotentiometer	Captador de movimiento	1
*18	155 680 016	Support capteur & entretoise	Sensor support & spacer	Halterung Potentiometer & Distanzstück	Soporte captador & Tirante	1
18a	NC / NS	▪ Support capteur	▪ Sensor support	▪ Poti-Anschluss	▪ Soporte captador	1
18b	055 680 018	▪ Entretoise	▪ Spacer	▪ Distanzstück	▪ Tirante	1

Ind	#	Désignation	Description	Bezeichnung	Denominación	Qté
19	055 680 008	Guide pour capteur	Guide for sensor	Potentiometer Führung	Guía para captador	1
20	NC / NS	Vis CHc M 5 x 30	Screw, model CHc M 5 x 30	Schraube, CHc M 5 x 30	Tornillo, tipo CHc M 5 x 30	4
21	055 680 051	Entraînement capteur	Sensor driving	Potentiometer Mitnehmer	Arrastre captador	1
22	055 680 004	Témoin de course	Stroke detector	Hubanzeiger	Téstigo de recorrido	1
23	NC / NS	Circlips	Ring	Sicherungsring	Anillo truarc	1
24	055 680 011	Tige de piston	Piston rod	Kolbenstange	Eje de pistón	1
25	209 600	Bride liaison	Connecting flange	Verbindungsflansch	Brida conexión	1
26	055 680 002	Bride accouplement	Coupling flange	Kupplungsflansch	Brida acoplamiento	1
27	NC / NS	Coude MF 1/2"	Elbow, model MF 1/2"	Winkelnippel, AG/IG 1/2"	Codo, tipo MH 1/2"	2
29	906 333 102	Bouchon 1/4" G	Plug, model 1/4" G	Stopfen, 1/4" G	Tapón, tipo 1/4" G	2
30	552 260	Raccord coudé M5	Elbow fitting, model M5	Winkelnippel M5	Racor acodado, tipo M5	1
32	933 151 196	Vis CHc M 6 x 16	Screw, model CHc M 6 x 16	Schraube, CHc M 6 x 16	Tornillo, tipo CHc M 6 x 16	4
33	NC / NS	Adaptateur M 1/2" G - M 3/4" BSP	Adaptator, model double male, 1/2" G - 3/4" BSP	Anschluss, AG 1/2" G - AG 3/4" BSP	Adaptador, tipo M 1/2" G - M 3/4" BSP	1
35	91 517	Connecteur	Connector	Stecker	Conectador	1
36	NC / NS	Vis CHc M 12 x 75	Screw, model CHc M 12 x 75	Schraube, CHc M 12 x 75	Tornillo, tipo CHc M 12 x 75	1
37	NC / NS	Joint NBR	NBR seal	NBR Dichtung	Junta NBR	1
38	NC / NS	Joint torique	O-Ring	O-Ring Dichtung	Junta tórica	1
39	NC / NS	Joint racleur	Scraper seal	Abstreifring	Junta rascadora	1
40	NC / NS	Circlips	Ring	Sicherungsring	Anillo truarc	1
41	NC / NS	Joint	Seal	Dichtung	Seal	1
42	NC / NS	Joint plat	Flat seal	Flachdichtung	Junta plana	1
43	930 151 446	Vis CHc M 8 x 35	Screw, model CHc M 8 x 35	Schraube, CHc M 8 x 35	Tornillo, tipo CHc M 8 x 35	5
44	NC / NS	Vis CHc M 12 x 35	Screw, model CHc M 12 x 35	Schraube, CHc M 12 x 35	Tornillo, tipo CHc M 12 x 35	3
45	NC / NS	Rondelle WZ 5	Washer, model WZ 5	Scheibe, M5	Arandela, tipo WZ 5	4
46	933 151 275	Vis CHc M 5 x 20	Screw, model CHc M 5 x 20	Schraube, CHc M 5 x 20	Tornillo, tipo CHc M 5 x 20	1
47	953 010 019	Ecrou HM 8	Nut, model HM 8	Mutter, HM 8	Tuerca, tipo HM 8	1
48	NC / NS	Cale de réglage	Adjustment block	Scheiben für Höhenpassung	Cuña de ajuste	1
49	NC / NS	Plaque complément de capot	Cover plate complement	Führungspplatte für Haube	Placa complemento de capó	1

Ind	#	Désignation	Description	Bezeichnung	Denominación	Qté
*	146 310 090	Pochette de joints moteur (Ind. 15, 23, 37, 38, 39, 40, 41, 42)	Seal kit air motor (Ind. 15, 23, 37, 38, 39, 40, 41, 42)	Dichtungssatz für Luftmotor (Pos. 15, 23, 37, 38, 39, 40, 41, 42)	Bolsa de juntas motor (Índ. 15, 23, 37, 38, 39, 40, 41, 42)	1

* Pièces de maintenance préconisées.

* Preceding the index number denotes a suggested spare part.

* Bezeichnete Teile sind empfohlene Ersatzteile.

* Piezas de mantenimiento preventivas.

N C : Non commercialisé.

N S : Denotes parts are not serviceable.

N S : Bezeichnete Teile gibt es nicht einzeln, sondern nur
komplett.

N S : no suministrado.

Doc. 573.080.050 Date/Datum/Fecha : 06/09/21 Annule/Cancela/ Ersetzt/Anula : 11/06/18	Modif. / Änderung : Ind. / Pos. 12b : 044 960 007 → NC / NS Ind. / Pos. 13b : 044 960 008 → NC / NS	Pièces de rechange Spare parts list Ersatzteilliste Piezas de repuesto
---	--	---

HYDRAULIQUE, modèle C100 (garniture mobile avec joint GT)	FLUID SECTION, model C100 (mobile packing with GT seal)	#
HYDRAULIKTEIL, Modell C100 (mobile Packung mit GT-Dichtungsring)	HIDRÁULICA, tipo C100 (guarnición móvil con junta GT)	144.960.000

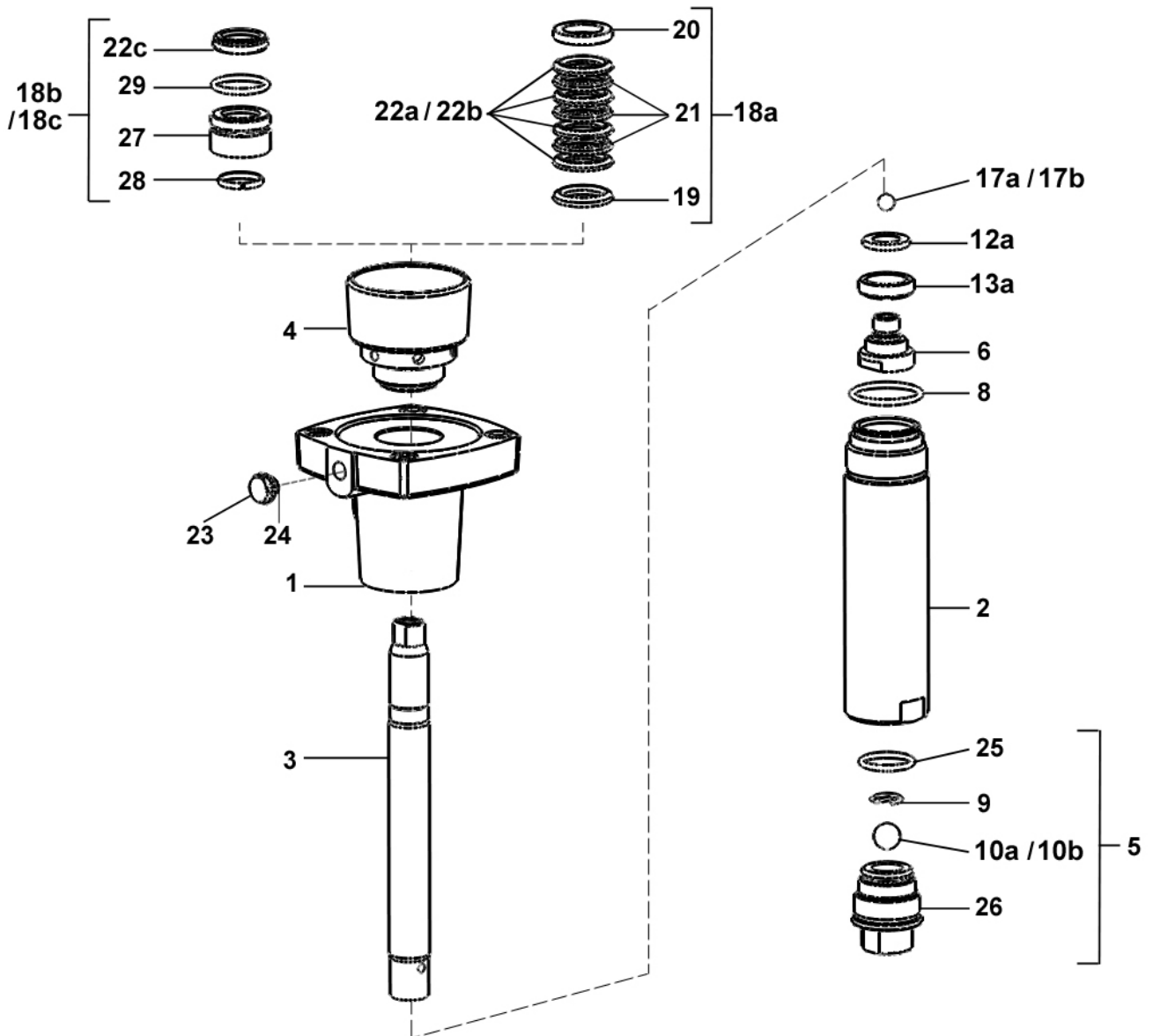

Hydraulique avec joint GT (à partir de la pompe N° série : 905 600)
Fluid section with GT seal (from pump serie N°: 905 600)
Hydraulikteil mit GT-Dichtungsring (ab Pumpe Serien-Nr. 905.600)
Hidráulica con junta GT (a partir de la bomba con el N° de serie : 905 600)

Ind	#	Désignation	Description	Bezeichnung	Denominación	Qté
1	044 960 001	Bride supérieure	Upper flange	oberer Flansch	Brida superior	1
*2	044 960 002	Cylindre	Cylinder	Materialzylinder	Cilindro	1
*3	044 960 003	Piston	Piston	Materialkolben	Pistón	1
4	044 950 004	Cuve presse-garniture	Wetting-cup	Spülmitteltasse	Cubeta prensa-guarnición	1
5	044 950 010	Clapet d'aspiration assemblé	Suction valve assembly	Ansaugventil, komplett	Válvula aspiración completa	1
9	044 550 029	▪ Jonc	▪ Rush	▪ Sicherungsring	▪ Anillo de retención bola	1
10a	907 414 242	▪ Bille Ø 16, inox 440C	▪ Ball Ø 16 (5/8"), stainless steel 440C	▪ Kugel, Ø 16, Edelstahl 440C	▪ Bola Ø 16 de inox 440C	1
25	050 040 318	▪ Joint torique	▪ O Ring	▪ O-Ring	▪ Junta tórica	1
26	NC / NS	▪ Corps de clapet	▪ Valve body	▪ Saugventil	▪ Cuerpo de válvula	1
*6	044 960 215	Clapet de refoulement	Exhaust valve	Druckventil	Válvula de expulsión	1
8	050 040 317	Joint torique	O Ring	O-Ring	Junta tórica	1
12a	044 960 204	Rondelle GT	Washer GT	Scheibe, GT	Arandela GT	1
13a	909 150 215	Joint GT inférieur (garniture mobile)	Seal GT lower (mobile packing)	GT Dichtung (mobile Packung)	Junta GT inferior (guarnición móvil)	1
17a	907 414 223	Bille Ø 9,52, inox 440C	Ball Ø 9,52 (3/8"), stainless steel 440C	Kugel, Ø 9,52, Edelstahl 440C	Bola Ø 9,52 de inox 440C	1
18a	-	Garniture supérieure	Upper packing	Obere Packung	Guarnición superior	1
19	044 960 011	▪ Bague male, inox	▪ Male ring, stainless steel	▪ Unterer Stützring, Edelstahl	▪ Anillo macho, inox	1
20	044 960 012	▪ Bague femelle, inox	▪ Female ring, stainless steel	▪ Oberer Stützring, Edelstahl	▪ Anillo hembra, inox	1
21	909 050 913	▪ Joint chevron, polyfluid	▪ Chevron seal, polyfluid	▪ Packungsring, Polyfluid	▪ Junta chevrón, polifluida	3
22a	109 050 818	▪ Joint chevron, PTFEG (pochette de 10)	▪ Chevron seal, PTFEG (pack of 10)	▪ Packungsring, PTFEG (10 St.)	▪ Junta chevrón, PTFEG (bolsa de 10)	4
23	144 950 012	Bouchon de vidange	Drain plug	Ablafschraube	Tapón de vaciado	1
24	109 020 401	▪ Joint plat (x 5)	▪ Flat seal (pack of 5)	▪ Flachdichtung (5 St.)	▪ Junta plana (bolsa de 5)	1

ACCESSOIRES - ACCESSORIES - ZUBEHÖR - ACCESORIOS

Ind. 31



Ind	#	Désignation	Description	Bezeichnung	Denominación	Qté
31	044 950 008	Clé pour cuve presse-garniture	Wrench for wetting-cup	Schlüssel für Spülmittel-tasse	Llave para prensaestopa	1
-	149 990 020	Flacon de lubrifiant T (125 ml)	T lubricant (125 ml / 4.4 oz)	Spülmittel T (125 ml)	Recipiente de lubricante T (125 ml)	1

POCHETTES - KITS - SÄTZE - BOLSAS

Ind	#	Désignation	Description	Bezeichnung	Denominación	Qté
*	144 960 091	Pochette de joints (ind. 8, 9, 10, 13, 17a, 21(x3), 22a(x4), 24, 25)	Package of seals (ind. 8, 9, 10, 13, 17a, 21(x3), 22a(x4), 24, 25)	Dichtungssatz (beinhaltet Pos. 8, 9, 10, 13, 17a, 21(x3), 22a(x4), 24, 25)	Bolsa de juntas (ind. 8, 9, 10, 13, 17a, 21(x3), 22a(x4), 24, 25)	1
*	144 960 096	Pochette de maintenance (ind. 5, 6, 12a + pochette de joints)	Servicing kit (ind. 5, 6, 12a + package of seals)	Servicekit (beinhaltet Pos. 5, 6, 12a und den Dichtungssatz)	Bolsa de mantenimiento (ind. 5, 6, 12a + bolsa de juntas)	1

* Pièces de maintenance préconisées.

* Preceding the index number denotes a suggested spare part.

* Bezeichnete Teile sind empfohlene Ersatzteile.

* Piezas de mantenimiento preventivas.

N C : Non commercialisé.

N S : Denotes parts are not serviceable.

N S : bezeichnete Teile gibt es nicht einzeln, sondern nur komplett.

N S : no suministrado.

OPTION - ON REQUEST - OPTIONEN - OPCIÓN

Ind	#	Désignation	Description	Bezeichnung	Denominación	Qté
10b	907 414 142	Bille Ø 16 inox 316 L	Ball Ø 16 stainless steel 316 L	Kugel (Edelstahl), Ø 16, 316 L	Bola Ø 16 de inox 316 L	1
17b	907 414 123	Bille Ø 9,52 inox 304 L	Ball Ø 9,52 stainless steel 304 L	Kugel (Edelstahl), Ø 9,52, 304 L	Bola Ø 9,52 de inox 304 L	1
18b	144 960 100	Cartouche supérieure avec joint GT	Upper packing with GT seal	Obere Packung, GT - Dichtung	Cartucho superior con junta GT	1
27	NC / NS	▪ Corps de cartouche	▪ Cartridge body	▪ Packungskörper	▪ Cuerpo de cartucho	1
28	NC / NS	▪ Segment	▪ Segment	▪ Ring	▪ Segmento	1
29	NC / NS	▪ Joint O-Ring noir	▪ O-Ring seal, black	▪ O-Ring, schwarz	▪ Junta tórica negra	1
22b	909 051 105	Joint chevron, PE	Chevron seal, PE	Packungsring, PE	Junta chevrón, PE	4

Pièces spécifiques - Specific parts - Spezifische Teile - Partes específicas

Pour garniture mobile avec joints chevrons / for mobile packing with chevron seals / für mobile Packung mit Packungsringen / para guarnición móvil con juntas de chevrón

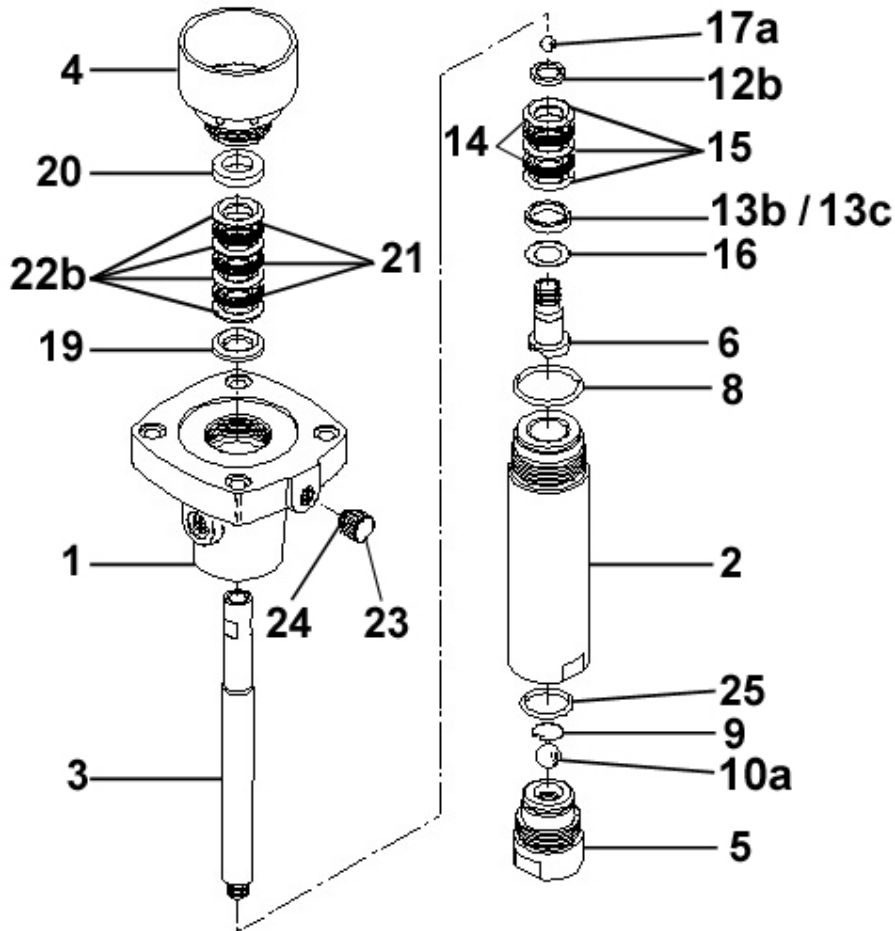

Ind	#	Désignation	Description	Bezeichnung	Denominación	Qté
6	044 960 010	Clapet de refoulement	Exhaust valve	Druckventil	Válvula de expulsión	1
12b	NC / NS	Rondelle mâle, inox	Male washer, stainless steel	Scheibe, außen, Edelstahl	Arandela macho, inox	1
13b	NC / NS	Rondelle femelle, inox	Female washer, stainless steel	Scheibe, innen, Edelstahl	Arandela hembra, inox	1
14	909 050 819	Joint chevron, PTFEG	Chevron seal, PTFEG	Packungsring, PTFEG	Junta chevrón, PTFEG	2
15	909 051 106	Joint chevron, PE	Chevron seal, PE	Packungsring, PE	Junta chevrón, PE	3
16	044 960 009	Rondelle de calage, inox (facultative)	Set ring, inox (optional)	Stützscheibe, Edelstahl (fakultativ)	Arandela inox (facultativa)	1

Ind	#	Désignation	Description	Bezeichnung	Denominación	Qté
*	144 960 090	Pochette de joints (ind. 8, 9, 10a, 14(x2), 15(x3), 16, 17a, 21(x3), 22b(x4), 24, 25)	Package of seals (ind. 8, 9, 10a, 14(x2), 15(x3), 16, 17a, 21(x3), 22b(x4), 24, 25)	Dichtungssatz (beinhaltet Pos. 8, 9, 10a, 14(x2), 15(x3), 16, 17a, 21(x3), 22b(x4), 24, 25)	Bolsa de juntas (ind. 8, 9, 10a, 14(x2), 15(x3), 16, 17a, 21(x3), 22b(x4), 24, 25)	1
*	144 960 095	Pochette de maintenance (ind. 5, 6 + pochette de joints)	Servicing kit (ind. 5, 6 + package of seals)	Servicekit (beinhaltet Pos. 5, 6 und den Dichtungssatz)	Bolsa de mantenimiento (ind. 5, 6 + bolsa de juntas)	1

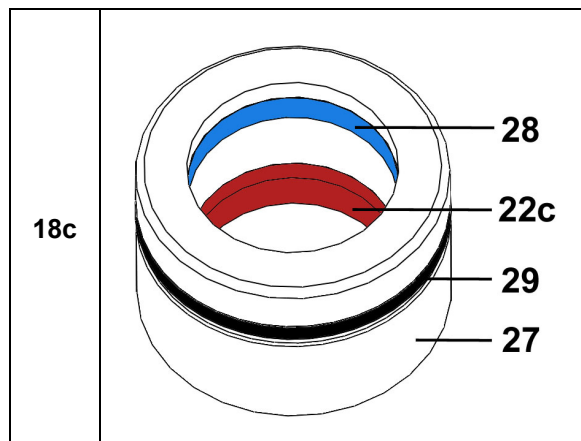

Ind	#	Désignation	Description	Bezeichnung	Denominación	Qté
13c	109 060 310	Joint de piston PU (pochette de 2)	Piston seal, Polyurethane (pack of 2)	Kolbendichtung, PU (2 St.)	Junta de pistón, Poliuretano (bolsa de 2)	1
18c	144 960 150	Cartouche supérieure avec joint PU	Upper packing with Polyurethane seal	Obere Packung, PU -Dichtung	Cartucho superior con junta de Poliuretano	1
22c	109 060 309	▪ Joint PU (pochette de 2)	▪ Seal, Polyurethane (pack of 2)	▪ PU-Dichtung (2 St.)	▪ Junta de Poliuretano (bolsa de 2)	1
27	NC / NS	▪ Corps de cartouche	▪ Cartridge body	▪ Packungskörper	▪ Cuerpo de cartucho	1
28	NC / NS	▪ Segment	▪ Segment	▪ Ring	▪ Segmento	1
29	NC / NS	▪ Joint O-Ring noir	▪ O-Ring seal, black	▪ O-Ring, schwarz	▪ Junta tórica negra	1

Ind	#	Désignation	Description	Bezeichnung	Denominación	Qté
*	144 960 159	Pochette de maintenance (ind. 8, 9, 10a, 13c, 17a, 18c, 25)	Service kit (ind. 8, 9, 10a, 13c, 17a, 18c, 25)	Servicekit (beinhaltet Pos. 8, 9, 10a, 13c, 17a, 18c, 25)	Bolsa de mantenimiento (ind. 8, 9, 10a, 13c, 17a, 18c, 25)	1

Doc. 573.114.050 Date/Datum/Fecha : 18/01/19 Annule/Cancela/ Ersetzt/Anula : 10/10/11	Modif. / Änderung : Mise à jour / Update / Aktualisierung / Actualización	Pièces de rechange Spare parts list Ersatzteilliste Piezas de repuesto
---	--	---

HYDRAULIQUE FLOWMAX®, modèle F100	FLOWMAX® FLUID SECTION, model F100	#
FLOWMAX® HYDRAULIKTEIL, Modell F100	HIDRÁULICA FLOWMAX®, tipo F100	144.960.200

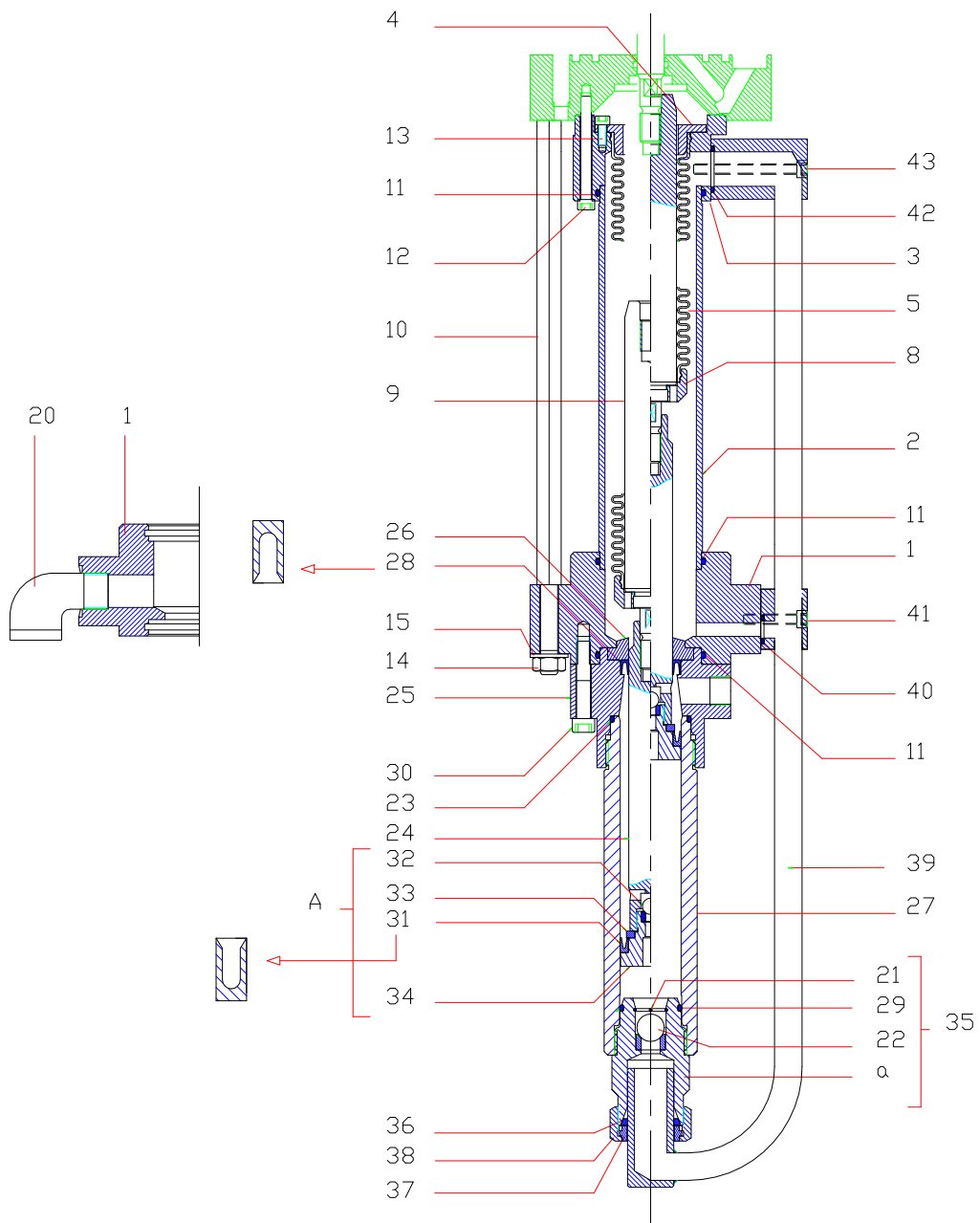

HYDRAULIQUE F100 INOX	FLUID SECTION, MODEL F100 STAINLESS STEEL	#
HYDRAULIKTEIL F100 EDELSTAHL	HIDRÁULICA F100 INOX	144.960.200

Ind	#	Désignation	Description	Bezeichnung	Denominación	Qté
1	044 970 451	Bride d'aspiration	Suction flange	Unterer Flansch	Brida de aspiración	1
2	044 970 052	Cylindre	Cylinder	Ansaugzylinder	Cilindro	1
3	044 970 445	Palier d'aspiration	Suction bearing	Oberer Flansch	Palier de aspiración	1
4	044 970 046	Bride soufflet	Flange, bellows	Faltenbalg-Flansch	Brida fuele	1
*5	044 970 055	Soufflet	Bellows	Faltenbalg	Fuelle	1
8	044 970 047	Jupe	Skirt	Klemmstück	Faldón	1
9	044 970 049	Piston intermédiaire	Piston, intermediate	Zwischenkolben	Pistón intermediario	1
10	044 970 060	Tirant d'accouplement	Coupling rod	Steuerstange	Tirante de acoplamiento	4
11	050 040 323	Joint PTFE	Seal, PTFE	Dichtung PTFE	Junta PTFE	3
12	930 151 598	Vis CHc M 6x60	Screw, model CHc M 6x60	Schraube M 6x60	Tornillo, tipo CHc M 6x60	4
13	931 151 168	Vis CHc M 5x12	Screw, model CHc M 5x12	Schraube M 5x12	Tornillo, tipo CHc M 5x12	4
14	953 010 021	Ecrou HM 10	Nut, model HM 10	Mutter M 10	Tuerca, tipo HM 10	4
15	963 040 021	Rondelle M 10	Washer, model M 10	Scheibe M 10	Arandela, tipo M 10	4
20	905 210 403	Coude inox MF 1/2	Elbow, model MF 1/2 (stainless steel)	Bogen AG/IG 1/2 Edelstahl	Codo, tipo MH 1/2 de inox	1
23	050 040 317	Joint PTFE	Seal, PTFE	Dichtung PTFE	Junta PTFE	1
*24	044 960 201	Piston	Piston	Kolben	Pistón	1
25	044 960 202	Bride de refoulement	Discharge flange	Druckflansch	Brida de expulsión	1
26	044 960 203	Bride joint GT	Flange, GT seal	GT-Dichtungsflansch	Brida junta GT	1
*27	044 960 002	Cylindre	Cylinder	Materialzylinder	Cilindro	1
28	909 150 213	Joint GT supérieur	GT seal, upper	Obere GT-Dichtung	Junta GT superior	1
30	933 151 526	Vis CHc M 8x45	Screw, model CHc M 8x45	Schraube M 8x45	Tornillo, tipo CHc M 8x45	4
* A	144 960 500	Ensemble clapet de refoulement	Exhaust valve kit	Druckventil komplett	Kit válvula de expulsión	1
31	909 150 215	▪ Joint GT inférieur	▪ GT seal, lower	▪ Untere GT- Dichtung	▪ Junta GT inferior	1
32	907 414 223	▪ Bille Ø 9,52, inox 440 C	▪ Ball, model Ø 9,52, (440 C stainless steel)	▪ Kugel Ø 9,52 Edelstahl	▪ Bola, tipo Ø 9,52 de inox 440 C	1
33	044 960 204	▪ Rondelle GT	▪ Washer, GT	▪ Scheibe GT	▪ Arandela GT	1
34	044 960 215	▪ Clapet de refoulement	▪ Exhaust valve	▪ Druckventil	▪ Válvula de expulsión	1

Ind	#	Désignation	Description	Bezeichnung	Denominación	Qté
*35	044 950 225	Clapet d'aspiration assemblé	Suction valve assembly	Saugventil komplett	Válvula de aspiración montada	1
a	NC / NS	▪ Corps de clapet	▪ Suction valve body	▪ Saugventilkörper	▪ Cuerpo de válvula	1
21	044 550 029	▪ Jonc	▪ Rush	▪ Sicherungsring	▪ Anillo de retención bola	1
22	907 414 242	▪ Bille Ø 16, inox 440C	▪ Ball, model Ø 16, 440C (stainless steel)	▪ Kugel Ø 16, Edelstahl	▪ Bola, tipo Ø 16 de inox 440C	1
29	050 040 318	▪ Joint torique PTFE	▪ O Ring PTFE	▪ O-Ring PTFE	▪ Junta tórica PTFE	1
36	144 970 106	Joint (les 10)	Seal (pack of 10)	O-Ring (10 St.)	Junta (bolsa de 10)	1
37	044 970 107	Bague de serrage	Tightening ring	Klemmring	Anillo de apriete	1
38	049 595 306	Ecrou raccord M 38x150	Nut fitting, model M 38x150	Überwurfmutter M 38x1,5	Tuerca racor, tipo M 38x150	1
39	044 950 271	Tube de liaison avec vis (ind. 41&43)	Fluid tube, attachment with screws (ind. 41&43)	Verbindungsrohr mit Schrauben (Pos. 41&43)	Tubo de unión con tornillos (ind. 41&43)	1
40	129 489 902	Joint PTFE (les 10)	Seal, PTFE (pack of 10)	Dichtung PTFE (10 St.)	Junta PTFE (bolsa de 10)	1
41	933 151 196	Vis CHc M 6x16	Screw, model CHc M 6x16	Schraube M 6x16	Tornillo, tipo CHc M 6x16	2
42	150 040 321	Joint PTFE (les 10)	Seal, PTFE (pack of 10)	Dichtung PTFE (10 St.)	Junta PTFE (bolsa de 10)	1
43	933 151 196	Vis CHc M 6x16	Screw, model CHc M 6x16	Schraube M 6x16	Tornillo, tipo CHc M 6x16	2

Ind	#	Désignation	Description	Bezeichnung	Denominación	Qté
*	144 960 291	Pochette de joints (ind. 11(x4), 21, 22, 23, 28, 29, 31, 32, 36, 40, 42)	Package of seals (ind. 11(x4), 21, 22, 23, 28, 29, 31, 32, 36, 40, 42)	Dichtungssatz (beinhaltet Pos. 11(x4), 21, 22, 23, 28, 29, 31, 32, 36, 40, 42)	Bolsa de juntas (ind. 11(x4), 21, 22, 23, 28, 29, 31, 32, 36, 40, 42)	1
*	144 960 292	Pochette de maintenance (ind. 33, 34, 35 + pochette de joints)	Servicing kit (ind. 33, 34, 35 + package of seals)	Servicekit (beinhaltet Pos. 33, 34, 35 und den Dichtungssatz)	Bolsa de reparación (ind. 33, 34, 35 + bolsa de juntas)	1

OPTIONS - ON REQUEST - OPTIONEN - OPCIONES

Ind	#	Désignation	Description	Bezeichnung	Denominación	Qté
22	907 414 142	Bille Ø 16 inox 316L	Ball Ø 16, 316L (stainless steel)	Kugel Ø 16, (Edelstahl 316L)	Bola Ø 16, inox 316L	1
32	907 414 123	Bille Ø 9,52 inox 316	Ball, model Ø 9,52 (316 stainless steel)	Kugel (Edelstahl 316) Ø 9,52	Bola, tipo Ø 9,52 de inox 316	1

* Pièces de maintenance préconisées.

* Preceding the index number denotes a suggested spare part.

* Bezeichnete Teile sind empfohlene Ersatzteile.

* Piezas de mantenimiento preventivas.

N C : Non commercialisé seul.

N S : Denotes parts are not serviceable.

N S : Bezeichnete Teile gibt nicht einzeln, sondern nur komplett

N S : no suministrado.

<p>Doc. 573.187.050 Date/Datum/Fecha : 07/05/21 Annule/Cancel/ Ersetzt/Anula : 03/01/19</p>	<p>Modif. / Änderung : Mise à jour / Update / Aktualisierung / Actualización</p>	<p>Pièces de rechange Spare parts list Ersatzteilliste Piezas de repuesto</p>
---	---	--

CTM	<p>CHANGEUR DE TEINTES INOX / STAINLESS STEEL COLOR CHANGER FARBWECHSELBLOCK - EDELSTAHL / CAMBIO DE COLOR INOX</p>
------------	--

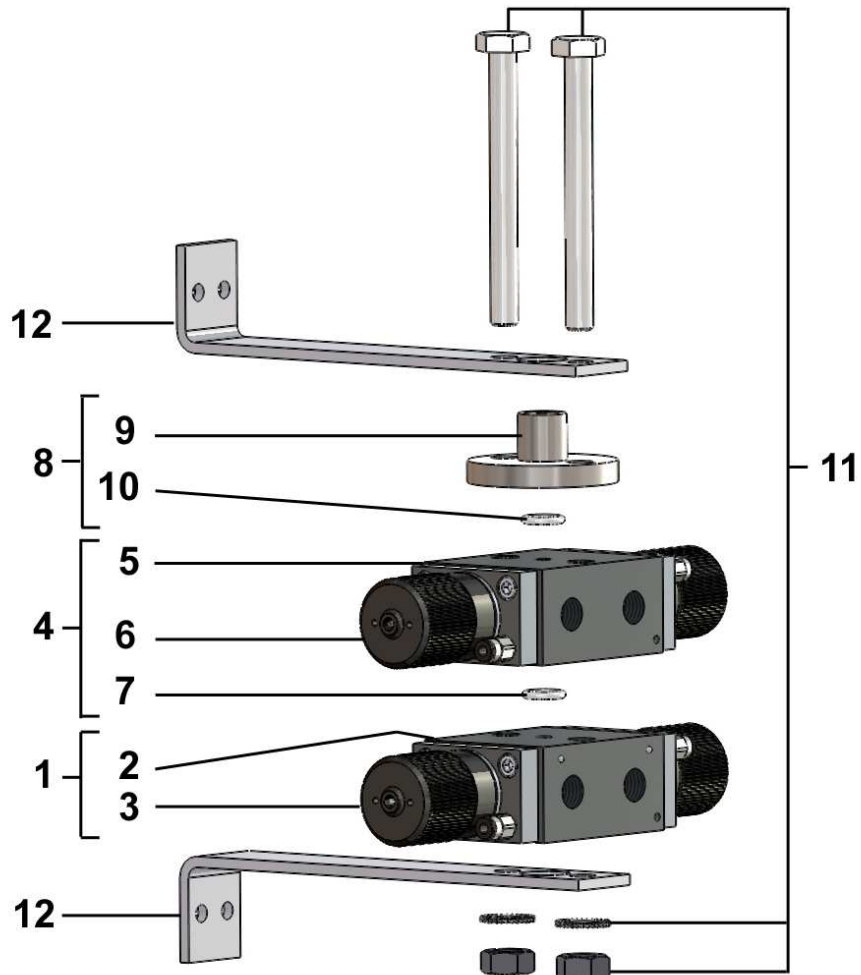

➡ **Ind 3 & 6 → Doc. / Dok. 573.188.050**

Version pneumatique / Airspray version / Niederdruck Version / Versión neumática

Ind	#	Désignation	Description	Bezeichnung	Denominación	Qté
*1	155 535 100	Module pneumatique d'extrémité	End module (material or solvent or air inlet)	Unteres Modul (Endmodul)	Modulo neumático de extremidad	1
2	055 535 101	• Corps du module	• Body	• Modulkörper	• Cuerpo del modulo	1
*3	155 535 110	• Vanne pneumatique	• Airspray valve	• Niederdruckventil	• Válvula neumática	2
*4	155 535 200	Module pneumatique de commutation	Intermediate module (material inlet only)	Zwischen-Modul (Materialeingang)	Modulo neumático intermediario	1XN
5	055 535 201	• Corps du module	• Body	• Modulkörper	• Cuerpo del modulo	1
*6	155 535 110	• Vanne pneumatique	• Airspray valve	• Niederdruckventil	• Válvula neumática	2
*7	155 535 710	• Joint PTFE (x 10)	• Seal, PTFE (x 10)	• PTFE-Dichtung (10 St.)	• Junta PTFE (x 10)	1

Version Airmix® (120 bar) / Airmix Version (120 bar / 1740 psi)

Ind	#	Désignation	Description	Bezeichnung	Denominación	Qté
*1	155 535 300	Module AIRMIX® d'extrémité (120 bar)	End module (material or solvent or air inlet)	Unteres Modul (Endmodul) (120 bar)	Modulo AIRMIX® de extremidad (120 bar)	1
2	055 535 301	• Corps du module	• Body	• Modulkörper	• Cuerpo del modulo	1
*3	155 535 310	• Vanne AIRMIX® (120 bar)	• AIRMIX valve (120 bar / 1740 psi)	• Airmix® -Ventil (120 bar)	• Válvula AIRMIX® (120 bar)	2
*4	155 535 400	Module AIRMIX® de commutation (120 bar)	Intermediate module (material inlet only) (120 bar / 1740 psi)	Zwischen-Modul (Materialeingang) (120 bar)	Modulo AIRMIX® intermediario (120 bar)	1XN
5	055 535 401	• Corps du module	• Body	• Modulkörper	• Cuerpo del modulo	1
*6	155 535 310	• Vanne AIRMIX® (120 bar)	• AIRMIX valve (120 bar / 1740 psi)	• AIRMIX® -Ventil (120 bar)	• Válvula AIRMIX® (120 bar)	2
*7	155 535 710	• Joint PTFE (les 10)	• Seal, PTFE (x 10)	• PTFE-Dichtung (10 St.)	• Junta PTFE (x 10)	1

Version Airmix® (200 bar) / Airmix® Version (200 bar / 2900 psi)

Ind	#	Désignation	Description	Bezeichnung	Denominación	Qté
*1	155 535 350	Module d'extrémité AIRMIX® GT (200 bar) (pour machine dont le numéro de série est > à 15T1003)	GT AIRMIX end module (material or solvent or air inlet) (200 bar / 2900 psi) (for machine which part number is > to 15T1003)	Unteres Modul GT (Endmodul für Material und Spülmittel oder Spülmittel und Pulsluft) (200 bar) (ab Seriennummer > 15T1003)	Modulo de extremidad AIRMIX® GT (200 bar) (para máquina cuyo número de serie es superior a 15T1003)	1
2	055 535 301	• Corps du module	• Body	• Modulkörper	• Cuerpo del modulo	1
*3	155 535 315	• Vanne AIRMIX® GT (200 bar)	• GT AIRMIX valve (200 bar / 2900 psi)	• AIRMIX® GT -Ventil (200 bar)	• Válvula AIRMIX® GT (200 bar)	2
*4	155 535 450	Module AIRMIX® de commutation (200 bar)	Intermediate module (material inlet only) (200 bar / 2900 psi)	Zwischen-Modul (Materialeingang) (200 bar)	Modulo AIRMIX® intermediario (200 bar)	1XN
5	055 535 401	• Corps du module	• Body	• Modulkörper	• Cuerpo del modulo	1
*3	155 535 315	• Vanne AIRMIX® GT (200 bar)	• GT AIRMIX valve (200 bar / 2900 psi)	• AIRMIX® GT -Ventil (200 bar)	• Válvula AIRMIX® GT (200 bar)	2
*7	155 535 710	• Joint PTFE (les 10)	• Seal, PTFE (x 10)	• PTFE-Dichtung (10 St.)	• Junta PTFE (x 10)	1

Pièces communes - Common parts - Gleiche Teile - Partes comunes

Ind	#	Désignation	Description	Bezeichnung	Denominación	Qté
*8	155 535 500	Bride de sortie équipée	Flange assembly, material outlet	Ausgangsflansch (Materialausgang) kpl.	Brida de salida equipada	1
9	NC / NS	•Bride de sortie nue	•Bare outlet flange	•Ausgangsflansch, nackt	•Brida de salida sola	1
*10	155 535 710	•Joint PTFE (les 10)	•Seal, PTFE (x 10)	•PTFE-Dichtung (10 St.)	•Junta PTFE (x 10)	1

CHANGEUR DE TEINTES INOX 316 L	COLOR CHANGER, 316 L STAINLESS STEEL
FARBWECHSELBLOCK, EDELSTAHL 316 L	CAMBIO DE COLOR INOX 316 L

Version Airmix® (200 bar) / Airmix Version (200 bar / 2900 psi)

Ind	#	Désignation	Description	Bezeichnung	Denominación	Qté
*1	155 536 200	Module AIRMIX® d'extrémité (200 bar) (inox 316 L)	End module (material or solvent or air inlet) (200 bar / 2900 psi) (stainless steel, 316 L)	Unteres Modul (Endmodul) (200 bar) (Edelstahl 316 L)	Modulo AIRMIX® de extremidad (200 bar) (inox 316 L)	1
2	055 536 301	•Corps du module (inox 316 L)	•Body (stainless steel, 316 L)	•Modulkörper (Edelstahl 316 L)	•Cuerpo del modulo (inox 316 L)	1
*3	155 536 300	•Vanne AIRMIX® (200 bar) (inox 316 L)	•AIRMIX valve (200 bar / 2900 psi) (stainless steel, 316 L)	•AIRMIX® -Ventil (200 bar) (Edelstahl 316 L)	•Válvula AIRMIX® (200 bar) (inox 316 L)	2
*4	155 536 320	Module AIRMIX® de commutation (200 bar) (inox 316 L)	Intermediate module (material inlet only) (200 bar / 2900 psi) (stainless steel, 316 L)	Zwischen-Modul (Materialeingang) (200 bar) (Edelstahl 316 L)	Modulo AIRMIX® intermédiaire (200 bar) (inox 316 L)	1XN
5	NC / NS	•Corps du module (inox 316 L)	•Body (stainless steel, 316 L)	•Modulkörper (Edelstahl 316 L)	•Cuerpo del modulo (inox 316 L)	1
*6	155 536 300	•Vanne AIRMIX® (200 bar) (inox 316 L)	•AIRMIX valve (200 bar / 2900 psi) (stainless steel, 316 L)	•Airmix® -Ventil (200 bar) (Edelstahl 316 L)	•Válvula AIRMIX® (200 bar) (inox 316 L)	2
*7	155 535 710	•Joint PTFE (les 10)	•Seal, PTFE (x 10)	•PTFE-Dichtung (10 St.)	•Junta PTFE (x 10)	1
*8	155 536 410	Bride de sortie équipée	Flange assembly, material outlet	Ausgangsflansch (Materialausgang) kpl.	Brida de salida equipada	1
9	NC / NS	•Bride de sortie nue (inox 316 L)	•Bare flange (stainless steel, 316 L)	•Ausgangsflansch, nackt (Edelstahl 316 L)	•Brida de salida sola (inox 316 L)	1
*10	155 535 710	•Joint PTFE (les 10)	•Seal, PTFE (x 10)	•PTFE-Dichtung (10 St.)	•Junta PTFE (x 10)	1

CHANGEUR DE TEINTES INOX 316 L NPTF	COLOR CHANGER, 316 L NPTF STAINLESS STEEL
FARBWECHSELBLOCK, EDELSTAHL 316 L NPTF	CAMBIO DE COLOR INOX 316 L NPTF

Version Airmix® (200 bar) / Airmix Version (200 bar / 2900 psi)

Ind	#	Désignation	Description	Bezeichnung	Denominación	Qté
*1	155 662 050	Module AIRMIX® d'extrémité (200 bar) (inox 316 L NPTF)	End module (material or solvent or air inlet) (200 bar / 2900 psi) (stainless steel, 316 L NPTF)	Unteres Modul (Endmodul) (200 bar) (Edelstahl 316 L NPTF)	Modulo AIRMIX® de extremidad (200 bar) (inox 316 L NPTF)	1
2	155 662 051	• Corps du module (inox 316 L NPTF)	• Body (stainless steel, 316 L NPTF)	• Modulkörper (Edelstahl 316 L NPTF)	• Cuerpo del modulo (inox 316 L NPTF)	1
*3	155 662 020	• Vanne AIRMIX® (200 bar) (inox 316 L NPTF)	• AIRMIX valve (200 bar / 2900 psi) (stainless steel, 316 L NPTF)	• AIRMIX® -Ventil (200 bar) (Edelstahl 316 L NPTF)	• Válvula AIRMIX® (200 bar) (inox 316 L NPTF)	2
*4	155 662 060	Module AIRMIX® de commutation (200 bar) (inox 316 L NPTF)	Intermediate module (material inlet only) (200 bar / 2900 psi) (stainless steel, 316 L NPTF)	Zwischen-Modul (Materialeingang) (200 bar) (Edelstahl 316 L NPTF)	Modulo AIRMIX® intermedio (200 bar) (inox 316 L NPTF)	1XN
5	155 662 062	• Corps du module (inox 316 L NPTF)	• Body (stainless steel, 316 L NPTF)	• Modulkörper (Edelstahl 316 L NPTF)	• Cuerpo del modulo (inox 316 L NPTF)	1
*6	155 662 020	• Vanne AIRMIX® (200 bar) (inox 316 L NPTF)	• AIRMIX valve (200 bar / 2900 psi) (stainless steel, 316 L NPTF)	• Airmix® -Ventil (200 bar) (Edelstahl 316 L NPTF)	• Válvula AIRMIX® (200 bar) (inox 316 L NPTF)	2
*7	155 535 710	• Joint PTFE (les 10)	• Seal, PTFE (x 10)	• PTFE-Dichtung (10 St.)	• Junta PTFE (x 10)	1
*8	155 536 410	Bride de sortie équipée	Flange assembly, material outlet	Ausgangsflansch (Materialausgang) kpl.	Brida de salida equipada	1
9	NC / NS	• Bride de sortie nue (inox 316 L)	• Bare flange (stainless steel, 316 L)	• Ausgangsflansch, nackt (Edelstahl 316 L)	• Brida de salida sola (inox 316 L)	1
*10	155 535 710	• Joint PTFE (les 10)	• Seal, PTFE (x 10)	• PTFE-Dichtung (10 St.)	• Junta PTFE (x 10)	1

* Pièces de maintenance préconisées

* Preceding the index number denotes a suggested spare part.

* Bezeichnete Teile sind empfohlene Ersatzteile.

* Piezas de mantenimiento preventivas.

N C : Non commercialisé.

N S : Denotes parts are not serviceable.

N S : Bezeichnete Teile gibt nicht einzeln, sondern nur komplett.

N S : no suministrado.

TIRANT / TIE-RODS / VERBINDUNGSBOLZEN / TIRANTE

Ind	#	Désignation	Description	Bezeichnung	Denominación	Qté
*11	---	Ensemble de 2 tirants pour :	Set of 2 tie-rods for :	Verbindungsbolzen (Satz mit 2 Stück) für:	Conjunto de 2 tirantes para :	1
-	155 535 610	• 1 module (1 d'extrémité + 1 bride)	• 1 module (1 end module + 1 flange)	• 1 Modul (1 Endmodul + 1 Ausgangsflansch)	• 1 modulo (1 de extremidad + 1 brida)	-
-	155 535 620	• 2 modules (1 d'extrémité + 1 de commutation + 1 bride)	• 2 modules (1 end module + 1 intermediate module + 1 flange)	• 2 Module (1 Endmodul + 1 Zwischenmodul + 1 Ausgangsflansch)	• 2 modulos (1 de extremidad + 1 intermediario + 1 brida)	-
-	155 535 630	• 3 modules (1 d'extrémité + 2 de commutation + 1 bride)	• 3 modules (1 end module + 2 intermediate modules + 1 flange)	• 3 Module (1 Endmodul + 2 Zwischenmodule + 1 Ausgangsflansch)	• 3 modulos (1 de extremidad + 2 intermediario + 1 brida)	-
-	155 535 640	• 4 modules (1 d'extrémité + 3 de commutation + 1 bride)	• 4 modules (1 end module + 3 intermediate modules + 1 flange)	• 4 Module (1 Endmodul + 3 Zwischenmodule + 1 Ausgangsflansch)	• 4 modulos (1 de extremidad + 3 intermediario + 1 brida)	-
-	155 535 650	• 5 modules (1 d'extrémité + 4 de commutation + 1 bride)	• 5 modules (1 end module + 4 intermediate modules + 1 flange)	• 5 Module (1 Endmodul + 4 Zwischenmodule + 1 Ausgangsflansch)	• 5 modulos (1 de extremidad + 4 intermediario + 1 brida)	-

Chaque tirant est équipé d'un écrou et d'une rondelle.

Each tie-rod is supplied with 1 nut and 1 washer.

Jeder Verbindungsbolzen wird mit 1 Mutter und 1 Beilagscheibe geliefert.

Cada tirante está equipado con una tuerca y una arandela.

OPTIONS - ON REQUEST - OPTIONEN - OPCIONES

Ind	#	Désignation	Description	Bezeichnung	Denominación	Qté
12	155 535 700	Ensemble de 2 équerres de fixation	Set of 2 wall mounting brackets	Haltewinkel (Satz mit 2 Winkel)	Conjunto de 2 escuadras de fijación	1

<p>Doc. 573.188.050 Date/Datum/Fecha : 18/02/21 Annule/Cancel/ Ersetzt/Anula : 02/01/19</p>	<p>Modif. / Änderung : Ind. / Pos. 11 a / 11 b → 11 Pour / For / Für / Para # 155 536 300: Ind. / Pos. 1c # 155 507 014 → Ind. / Pos. 1b # 155 507 013 Ind. / Pos. 1c supprimé / canceled / Annulliert / suprimido Ind. / Pos. 1d : 155 662 011 → 029 930 202 Pour / For / Für / Para # 155 662 010: # 155 662 099 → # 129 529 918</p>	<p>Pièces de rechange Spare parts list Ersatzteilliste Piezas de repuesto</p>
---	---	--

<p>VANNE CTM en inox pour changeur de teintes</p>	<p>CTM VALVE (stainless steel) for color changer</p>
<p>CTM FARBWECHSEL-VENTIL (Edelstahl)</p>	<p>VÁLVULAS CTM de inox para cambiador de color</p>

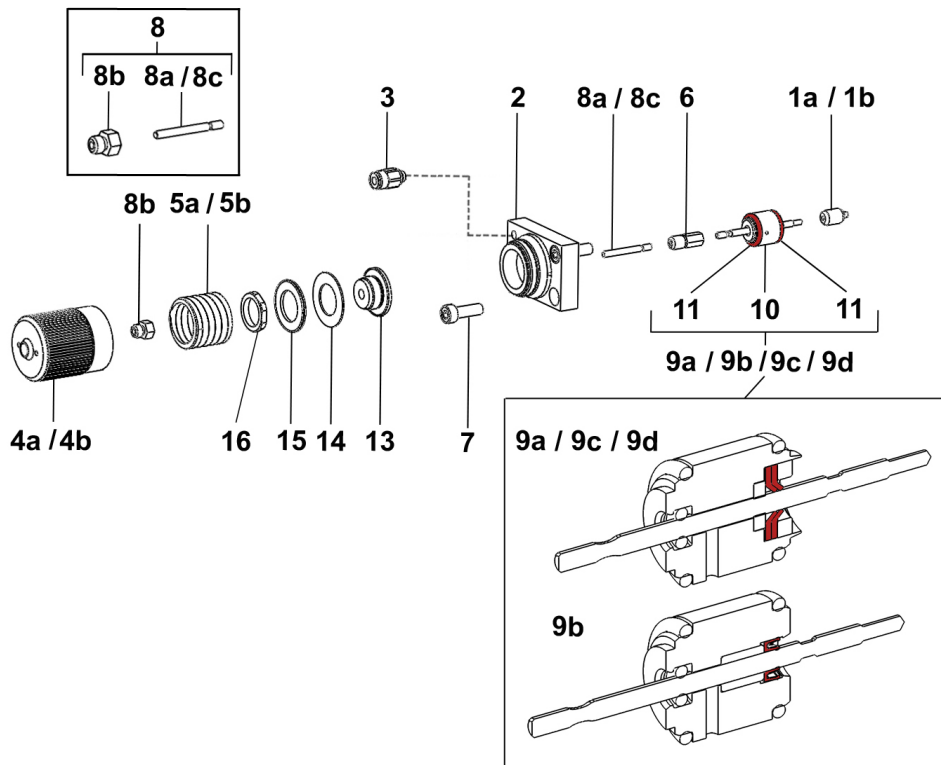

<div style="text-align: center;"> </div> <p>Respecter la cote de montage A (1+9+6+8a). Comply with the dimension value A (1+9+6+8a). Bei der Montage das Maß A einhalten (1+9+6+8a). Cumplir con la cota de montaje A (1+9+6+8a).</p>	<div style="text-align: center;"> </div> <table border="1" style="width: 100%; border-collapse: collapse; margin-top: 10px;"> <thead> <tr> <th colspan="5" style="text-align: center;">A (mm / ")</th> </tr> </thead> <tbody> <tr> <td style="text-align: center;">155 535 110</td> <td style="text-align: center;">155 535 310</td> <td style="text-align: center;">155 535 315</td> <td style="text-align: center;">155 536 300</td> <td style="text-align: center;">155 662 020</td> </tr> <tr> <td style="text-align: center;">78,5 / 3.09</td> <td style="text-align: center;">77 / 3.03</td> <td colspan="3" style="text-align: center;">82,9 / 3.26</td> </tr> </tbody> </table>	A (mm / ")					155 535 110	155 535 310	155 535 315	155 536 300	155 662 020	78,5 / 3.09	77 / 3.03	82,9 / 3.26		
A (mm / ")																
155 535 110	155 535 310	155 535 315	155 536 300	155 662 020												
78,5 / 3.09	77 / 3.03	82,9 / 3.26														

VANNE PNEUMATIQUE	AIRSPRAY VALVE	#
NIEDERDRUCK-VENTIL	VÁLVULA NEUMÁTICA	155.535.110

VANNE AIRMIX® 120 bar	AIRMIX VALVE (120 bar / 1740 psi)	#
AIRMIX® - VENTIL (120 bar)	VÁLVULA AIRMIX® 120 bar	155.535.310

VANNE AIRMIX® GT 200 bar	GT AIRMIX VALVE (200 bar / 2900 psi)	#
AIRMIX® GT - VENTIL (200 bar)	VÁLVULA AIRMIX® GT 200 bar	155.535.315

VANNE AIRMIX® 200 bar (inox 316 L)	AIRMIX VALVE (200 bar / 2900 psi) (stainless steel, 316 L)	#
AIRMIX® - VENTIL (200 bar), (Edelstahl 316 L)	VÁLVULA AIRMIX® 200 bar (inox 316 L)	155.536.300

VANNE AIRMIX® 200 bar (inox 316 L NPTF)	AIRMIX VALVE (200 bar / 2900 psi) (stainless steel, 316 L NPTF)	#
AIRMIX® - VENTIL (200 bar), (Edelstahl 316 L NPTF)	VÁLVULA AIRMIX® 200 bar (inox 316 L NPTF)	155.662.020

Pièces communes - Common parts - Gleiche Teile - Partes comunes

Ind	#	Désignation	Description	Bezeichnung	Denominación	Qté
3	905 120 944	Raccord droit M5 (air commande ouverture)	Air connector, M5 (control air)	Steckanschluss, M5 (Steuerluft)	Racor recto M5 (aire de mando de apertura)	1
6	055 501 003	Entraîneur de tige	Rod carrier	Stangenführung	Arrastre de eje	1
7	933 151 221	Vis CHc M5 x 16	Screw, model CHc M5 x 16	Schraube, CHc M5 x 16	Tornillo, tipo CHc M5 x 16	3
13	029 875 301	Piston seul	Piston only	Kolben, einzeln	Pistón solo	1
*14	029 711 302	Garniture	Packing	Kolbenmanschette	Guarnición	1
15	029 711 303	Rondelle d'appui	Support washer	Scheibe	Arandela de apoyo	1
16	029 711 304	Ecrou M 16 x 100	Nut, model M 16 x 100	Mutter, M 16 x 1,00	Tuerca, tipo M 16 x 100	1

* Pièces de maintenance préconisées.

* Preceding the index number denotes a suggested spare part.

* Bezeichnete Teile sind empfohlene Ersatzteile.

* Piezas de mantenimiento preventivas.

N C : Non commercialisé.

N S : Denotes parts are not serviceable.

N S : Bezeichnete Teile gibt es nicht einzeln, sondern nur komplett .

N S : no suministrado.

Pièces spécifiques - Specific parts - Spezifische Teile - Partes específicas

Pour / for / für / para # 155.535.110

Ind	#	Désignation	Description	Bezeichnung	Denominación	Qté
*1a	155 501 004	Pointeau	Needle	Nadel	Aguja	1
2a	055 535 121	Support cylindre	Support, cylinder	Zylinderhalterung	Soporte cilindro	1
4a	029 711 401	Cylindre	Cylinder	Zylinder	Cilindro	1
5a	050 313 504	Ressort	Spring	Feder	Muelle	1
8	155 501 007	Témoin d'ouverture	Valve opening indicator	Schaltzustandsanzeiger	Testigo de apertura	1
8c	055 501 008	▪ Tige	▪ Rod	▪ Stange	▪ Eje	1
8b	055 501 009	▪ Guide	▪ Guide	▪ Führung	▪ Guía	1
*9a	155 535 140	Cartouche équipée	Cartridge assembly	Packung, kpl	Cartucho equipado	1
10	NC / NS	▪ Cartouche avec tige	▪ Cartridge with rod	▪ Packung mit Stange	▪ Cartucho con eje	1
*11	129 529 918	▪ Joint PTFE (les 10)	▪ Seal, PTFE (pack of 10)	▪ Dichtung PTFE (10 St.)	▪ Junta PTFE (bolsa de 10)	2

Pour / for / für / para # 155.535.310

Ind	#	Désignation	Description	Bezeichnung	Denominación	Qté
*1b	155 507 013	Pointeau	Needle	Nadel	Aguja	1
2a	055 535 121	Support cylindre	Support, cylinder	Zylinderhalterung	Soporte cilindro	1
4a	029 711 401	Cylindre	Cylinder	Zylinder	Cilindro	1
5a	050 313 504	Ressort	Spring	Feder	Muelle	1
8	155 501 007	Témoin d'ouverture	Valve opening indicator	Schaltzustandsanzeiger	Testigo de apertura	1
8c	055 501 008	▪ Tige	▪ Rod	▪ Stange	▪ Eje	1
8b	055 501 009	▪ Guide	▪ Guide	▪ Führung	▪ Guía	1
*9a	155 535 140	Cartouche équipée	Cartridge assembly	Packung, kpl	Cartucho equipado	1
10	NC / NS	▪ Cartouche avec tige	▪ Cartridge with rod	▪ Packung mit Stange	▪ Cartucho con eje	1
*11	129 529 918	▪ Joint PTFE (les 10)	▪ Seal, PTFE (pack of 10)	▪ Dichtung PTFE (10 St.)	▪ Junta PTFE (bolsa de 10)	2

Pour / for / für / para # 155.535.315

Ind	#	Désignation	Description	Bezeichnung	Denominación	Qté
*1b	155 507 013	Pointeau	Needle	Nadel	Aguja	1
2a	055 535 121	Support cylindre	Support, cylinder	Zylinderhalterung	Soporte cilindro	1
4b	055 535 316	Cylindre	Cylinder	Zylinder	Cilindro	1
5b	050 316 501	Ressort	Spring	Feder	Muelle	1
8	-	Témoin d'ouverture	Valve opening indicator	Schaltzustandsanzeiger	Testigo de apertura	1
8a	055 501 010	▪ Tige	▪ Rod	▪ Stange	▪ Eje	1
8b	055 501 009	▪ Guide	▪ Guide	▪ Führung	▪ Guía	1
*9b	155 528 012	Cartouche équipée	Cartridge assembly	Packung, kpl	Cartucho equipado	1
10	NC / NS	▪ Cartouche avec tige	▪ Cartridge with rod	▪ Packung mit Stange	▪ Cartucho con eje	1
*11	129 529 918	▪ Joint PTFE (les 10)	▪ Seal, PTFE (pack of 10)	▪ Dichtung PTFE (10 St.)	▪ Junta PTFE (bolsa de 10)	2

Pour / for / für / para # 155.536.300

Ind	#	Désignation	Description	Bezeichnung	Denominación	Qté
*1b	155 507 013	Pointeau	Needle	Nadel	Aguja	1
2a	055 535 121	Support cylindre	Support, cylinder	Zylinderhalterung	Soporte cilindro	1
4b	055 535 316	Cylindre	Cylinder	Zylinder	Cilindro	1
5b	050 316 501	Ressort	Spring	Feder	Muelle	1
8	-	Témoin d'ouverture	Valve opening indicator	Schaltzustandsanzeiger	Testigo de apertura	1
8a	055 501 010	▪ Tige	▪ Rod	▪ Stange	▪ Eje	1
8b	055 501 009	▪ Guide	▪ Guide	▪ Führung	▪ Guía	1
*9c	155 536 350	Cartouche équipée (inox 316 L)	Cartridge assembly (stainless steel, 316 L)	Packung, kpl (Edelstahl 316 L)	Cartucho equipado (inox 316L)	1
10	NC / NS	▪ Cartouche avec tige	▪ Cartridge with rod	▪ Packung mit Stange	▪ Cartucho con eje	1
*11	129 529 918	▪ Joint PTFE (les 10)	▪ Seal, PTFE (pack of 10)	▪ Dichtung PTFE (10 St.)	▪ Junta PTFE (bolsa de 10)	2

Pour / for / für / para # 155.662.020

Ind	#	Désignation	Description	Bezeichnung	Denominación	Qté
*1d	029 930 202	Pointeau	Needle	Nadel	Aguja	1
2b	155 662 021	Support cylindre	Support, cylinder	Zylinderhalterung	Soporte cilindro	1
4b	055 535 316	Cylindre	Cylinder	Zylinder	Cilindro	1
5b	050 316 501	Ressort	Spring	Feder	Muelle	1
8	-	Témoin d'ouverture	Valve opening indicator	Schaltzustandsanzeiger	Testigo de apertura	1
8a	055 501 010	▪ Tige	▪ Rod	▪ Stange	▪ Eje	1
8b	055 501 009	▪ Guide	▪ Guide	▪ Führung	▪ Guía	1
*9d	155 662 010	Cartouche équipée (inox 316 L)	Cartridge assembly (stainless steel, 316 L)	Packung, kpl (Edelstahl 316 L)	Cartucho equipado (inox 316L)	1
10	NC / NS	▪ Cartouche avec tige	▪ Cartridge with rod	▪ Packung mit Stange	▪ Cartucho con eje	1
*11	129 529 918	▪ Joint PTFE (les 10)	▪ Seal, PTFE (pack of 10)	▪ Dichtung PTFE (10 St.)	▪ Junta PTFE (bolsa de 10)	2

* Pièces de maintenance préconisées.

* Preceding the index number denotes a suggested spare part.

* Bezeichnete Teile sind empfohlene Ersatzteile.

* Piezas de mantenimiento preventivas.

N C : Non commercialisé.

N S : Denotes parts are not serviceable.

N S : Bezeichnete Teile gibt es nicht einzeln, sondern nur komplett.

N S : no suministrado.

Doc. 573.299.050 Date/Datum/Fecha : 20/07/18 Annule/Cancela/ Ersetzt/Anula : 10/06/11	Modif. / Änderung : Mise à jour / Update / Aktualisierung / Actualización KREMLIN REXSON → SAMES KREMLIN	Pièces de rechange Spare parts list Ersatzteilliste Piezas de repuesto
---	---	---

FILTRE PRODUIT HP, modèle 3/8 inox	HP FLUID FILTER, model 3/8 stainless steel
HD MATERIALFILTER, Modell 3/8 Edelstahl	FILTRO PRODUCTO AP, tipo 3/8 inox

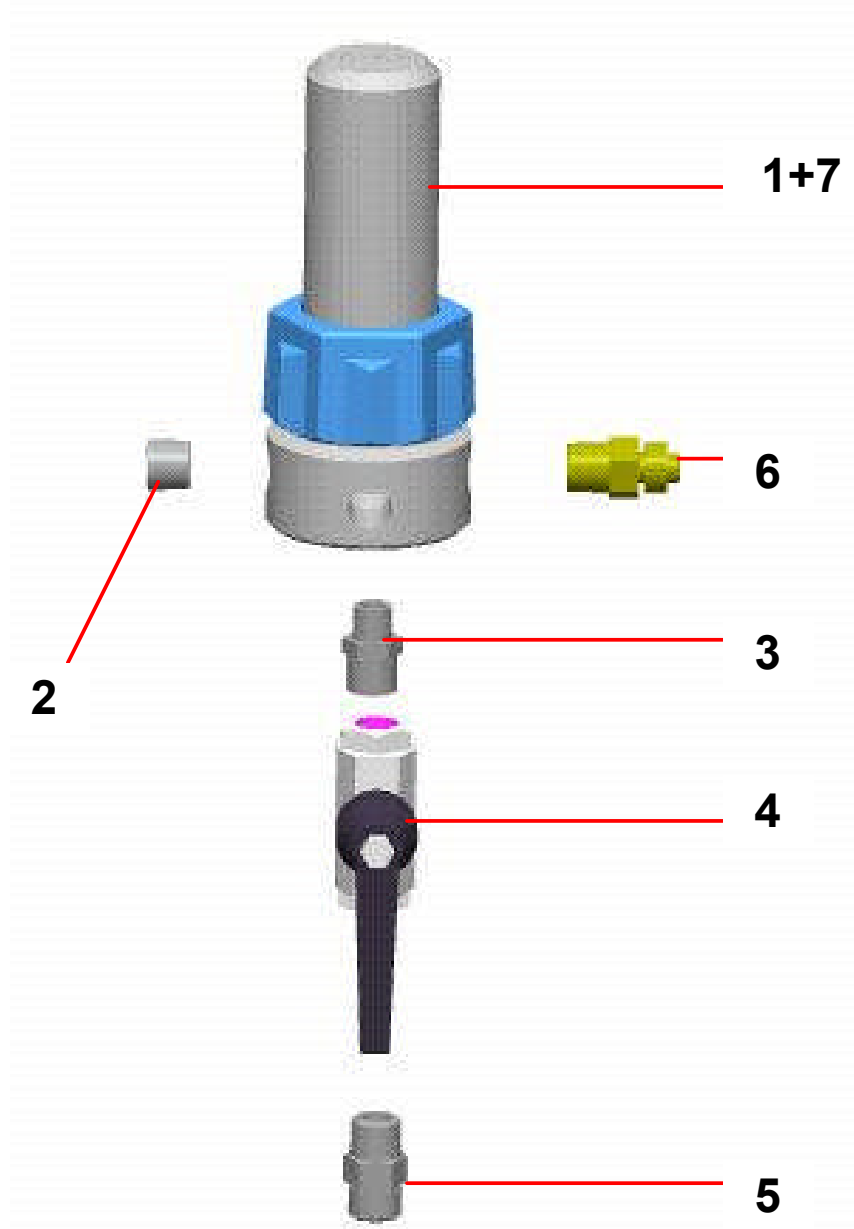

FILTRE EQUIPÉ pour pompes AIRMIX®	FILTRE EQUIPÉ pour pompes AIRLESS®
EQUIPPED FILTER for AIRMIX® pumps	EQUIPPED FILTER for AIRLESS pumps
AUSGERÜSTETER FILTER für AIRMIX®-Pumpen	AUSGERÜSTETER FILTER für AIRLESS®-Pumpen
FILTRO EQUIPADO para bombas AIRMIX®	FILTRO EQUIPADO para bombas AIRLESS®
# 155.580.300	# 155.580.400

PIECES COMMUNES - COMMON PARTS - GLEICHE TEILE - PARTES COMUNES

Ind	#	Désignation	Description	Bezeichnung	Denominación	Qté
*1	155 580 200	Filtre nu inox	Bare filter, stainless steel	Nackter Filter - Edelstahl	Filtro solo, inox	1
2	905 210 304	Bouchon inox 3/8 NPT	Plug , stainless steel 3/8 NPT	Blindstopfen - Edelstahl 3/8 NPT	Tapón de inox 3/8 NPT	1
3	906 314 204	Raccord inox M 1/4 - M 3/8	Fitting, double male, 1/4 - 3/8	Doppelnippel AG 1/4 - AG 3/8	Racor inox, M 1/4 - M 3/8	1
*4	000 750 040	Vanne HP FF 3/8 BSP	HP valve FF 3/8 BSP	Kugelhahn, IG 3/8 BSP	Válvula, AP 3/8 BSP	1
5	050 102 411	Raccord inox M 18 x 125 - M 3/8 BSP	Adaptor, stainless steel, double male 18x125 - 3/8BSP	Doppelnippel - Edelstahl AG 3/8 BSP - M 18x1,25	Racor inox, M 18 x 125 - M 3/8 BSP	1
6	905 210 503	Raccord inox M 3/8 NPT - M 1/2 JIC	Adaptor, stainless steel, double male, 3/8 NPT - # 5 JIC (1/2 JIC)	Doppelnippel Edelstahl 3/8 NPT - 1/2 JIC	Racor, inox M 3/8 NPT - M 1/2 JIC	1

PIECES SPECIFIQUES - SPECIFIC PARTS - SPEZIELLE TEILE - PARTES ESPECIFICAS

⇒ **Filtre / Filter / Filtro # 155.580.300**

Ind	#	Désignation	Description	Bezeichnung	Denominación	Qté
*7	000 161 106	Tamis n° 6 (168 µ)	Screen n° 6 (168 µ - 85 Mesh)	Filterelement Sieb Nr. 6 (168 µ)	Tamiz n° 6 (168 µ)	1

⇒ **Filtre / Filter / Filtro # 155.580.400**

Ind	#	Désignation	Description	Bezeichnung	Denominación	Qté
*7	000 161 112	Tamis n° 12 (280 µ)	Screen n° 12 (280 µ - 55 Mesh)	Filterelement Sieb Nr. 12 (280 µ)	Tamiz n° 12 (280 µ)	1

* Pièces de maintenance préconisées.

* Preceding the index number denotes a suggested spare part.

* Bezeichnete Teile sind empfohlene Ersatzteile.

* Piezas de mantenimiento preventivas.

FILTRE NU (sans tamis)	BARE FILTER (without screen)	#
NACKTER FILTER (ohne Sieb)	FILTRO SOLO (sin tamiz)	155.580.200

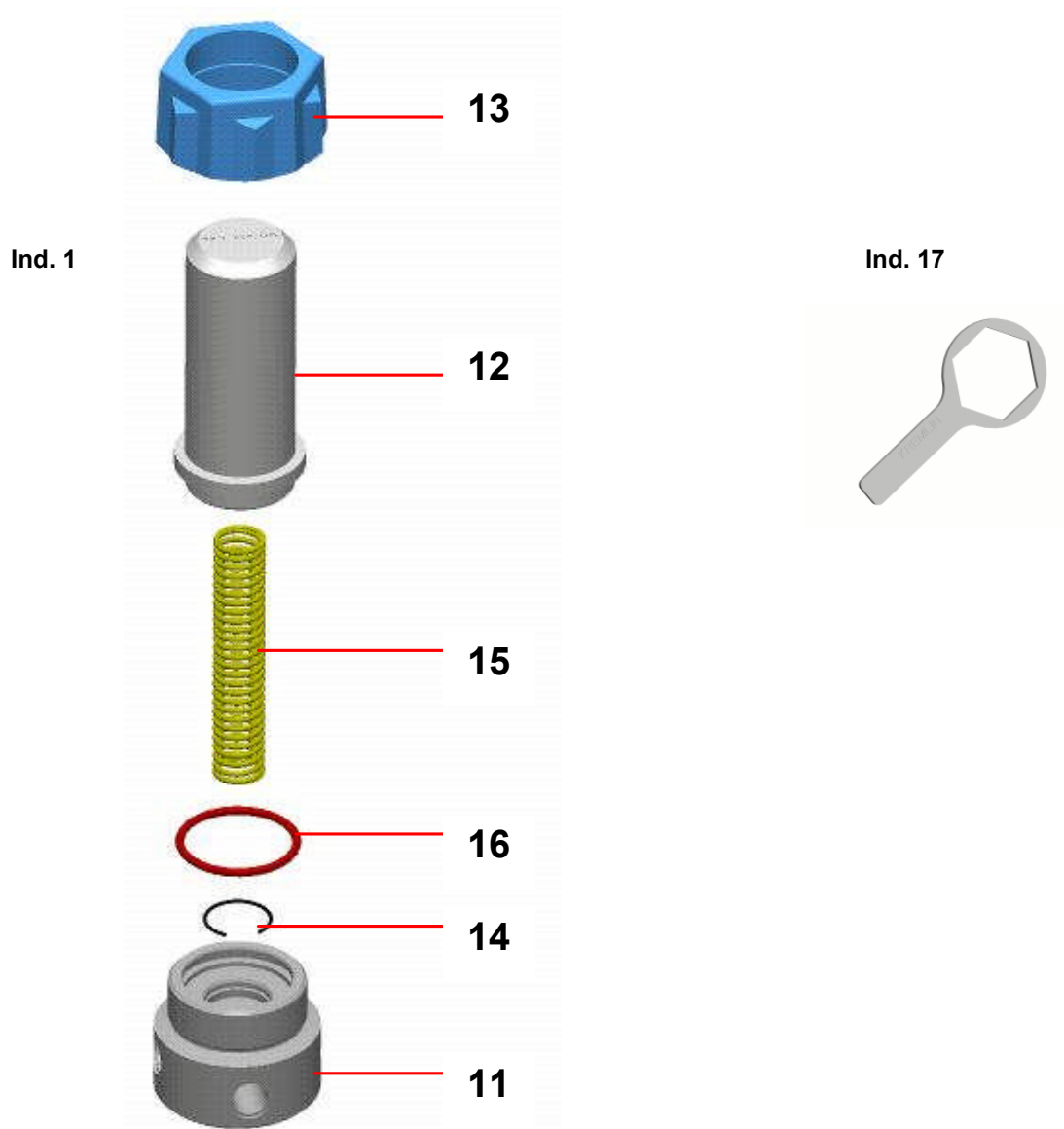

Ind	#	Désignation	Description	Bezeichnung	Denominación	Qté
11	055 580 201	Embbase 3/8	Base, model 3/8	Grundblock, Modell 3/8	Base, tipo 3/8	1
12	055 580 202	Cuve	Bowl	Filterglocke	Cubeta	1
13	055 280 002	Ecrou	Nut	Überwurfmutter	Tuerca	1
14	055 190 007	Jonc	Stop ring	Sicherungsring	Clips	1
15	055 190 005	Ressort	Spring	Feder	Muelle	1
*16	150 040 327	Joint (les 5)	Seal (pack of 5)	Dichtung (5 St.)	Junta (bolsa de 5)	1
17	049 030 018	Clé de démontage	Wrench	Schlüssel	Llave de desmontaje	1

A LA DEMANDE - ON REQUEST - AUF WUNSCH - A PETICIÓN

Ind. 7



Ind	#	Désignation	Description	Bezeichnung	Denominación	Qté
-	000 161 101	Tamis n° 1 (37 µ)	Screen n° 1 (37 µ)	Sieb Nr. 1 (37 µ)	Tamiz n° 1 (37µ)	1
-	000 161 102	Tamis n° 2 (77 µ)	Screen n° 2 (77 µ)	Sieb Nr. 2 (77 µ)	Tamiz n° 2 (77 µ)	1
-	000 161 104	Tamis n° 4 (99 µ)	Screen n° 4 (99 µ)	Sieb Nr. 4 (99 µ)	Tamiz n° 4 (99 µ)	1
7	000 161 106	Tamis n° 6 (168 µ)	Screen n° 6 (168 µ)	Sieb Nr. 6 (168 µ)	Tamiz n° 6 (168 µ)	1
-	000 161 108	Tamis n° 8 (210 µ)	Screen n° 8 (210 µ)	Sieb Nr. 8 (210 µ)	Tamiz n° 8 (210 µ)	1
7	000 161 112	Tamis n° 12 (280 µ)	Screen n° 12 (280 µ)	Sieb Nr. 12 (280 µ)	Tamiz n° 12 (280 µ)	1
-	000 161 115	Tamis n° 15 (360 µ)	Screen n° 15 (360 µ)	Sieb Nr. 15 (360 µ)	Tamiz n° 15 (360 µ)	1
-	000 161 020	Tamis n° 20 (510 µ)	Screen n° 20 (510 µ)	Sieb Nr. 20 (510 µ)	Tamiz n° 20 (510 µ)	1
-	000 161 030	Tamis n° 30 (750 µ)	Screen n° 30 (750 µ)	Sieb Nr. 30 (750 µ)	Tamiz n° 30 (750 µ)	1

OPTIONS - ON REQUEST - OPTIONEN - OPCIONES

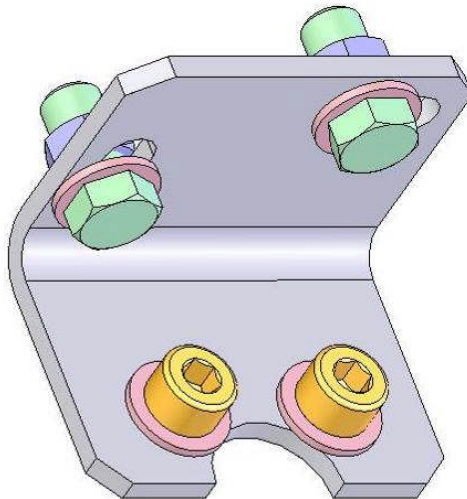

Ind	#	Désignation	Description	Bezeichnung	Denominación	Qté
-	155 190 105	Support filtre avec vis, rondelles et écrous	Mounting bracket with screws, washers and nuts	Filterhalterung mit Schrauben, Scheiben und Muttern	Soporte filtro con tornillos, arandelas y tuercas	1

<p>Doc. 573.438.050 Date/Datum/Fecha : 05/11/19 Annule/Cancel/ Ersetzt/Anula : 13/12/13</p>	<p>Modif. / Änderung : EOS supprimé / canceled / annulliert / suprimido #905 120 913 → #905 270 913</p>	<p>Pièces de rechange Spare parts list Ersatzteilliste Piezas de repuesto</p>
---	---	--

<p>POMPE DE RINCAGE POUR POMPE PU 3000, modèle 30-C25</p>	<p>FLUSHING PUMP FOR PU 3000 PUMP, model 30-C25</p>
<p>SPÜLPUMPE FÜR PU 3000 PUMPE, Modell 30-C25</p>	<p>BOMBA DE LIMPIEZA PARA BOMBA PU 3000 , tipo 30-C25</p>

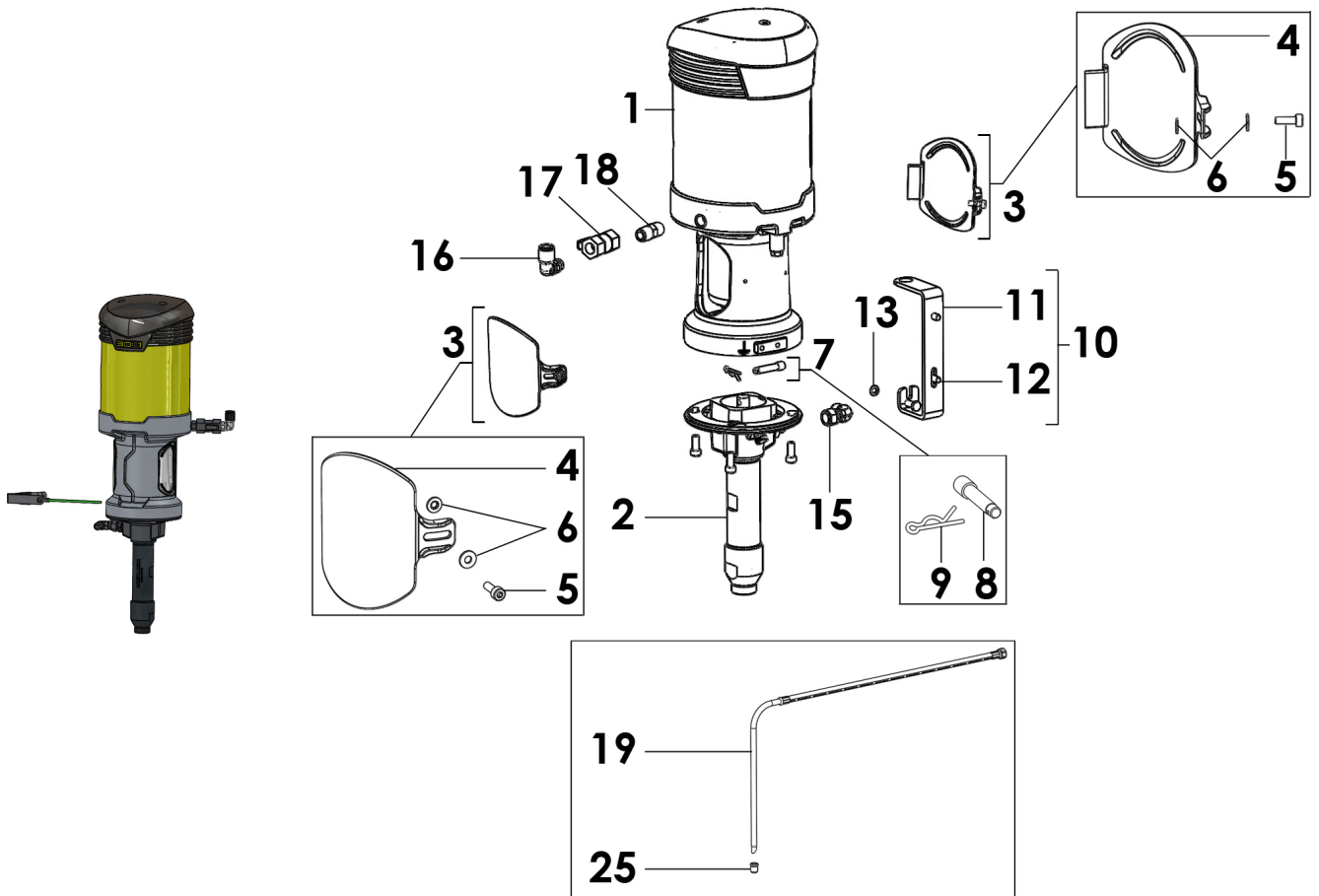

POMPE DE RINCAGE POUR POMPE PU 3000, modèle 30-C25	FLUSHING PUMP FOR PU 3000 PUMP, model 30-C25	# 151.145.090
SPULPUMPE FÜR PUMPE PU 3000, Modell 30-C25	BOMBA DE LIMPIEZA PARA BOMBA PU 3000 tipo 30-C25	

Ind	#	Désignation	Description	Bezeichnung	Denominación	Qté
-	-	Pompe nue inox	Bare pump, stainless steel	Pumpe nackt, Edelstahl	Bomba sola de inox	1
1	NC / NS	▪ Moteur 420-4 (voir Doc. 573.435.050)	▪ Air motor, model 420-4 (refer to Doc. 573.435.050)	▪ Luftmotor, Modell 420-4 (Siehe Dok. 573.435.050)	▪ Motor, tipo 420-4 (Consultar Doc. 573.435.050)	1
*2	144 130 200	▪ Hydraulique C-25 (Entrée produit M 16x125) (voir Doc. 573.434.050)	▪ Fluid section, model C-25 (Material inlet M 16x125) (refer to Doc. 573.434.050)	▪ Hydraulikteil, Modell C-25 (Materialeingang AG M16x1,25) (Siehe Dok. 573.434.050)	▪ Hidráulica, tipo C-25 (Entrada producto M 16x125) (Consultar Doc. 573.434.050)	1
*3	144 130 013	▪ Kit cache accouplement	▪ Coupling housing kit	▪ Schutzdeckelkit	▪ Kit cárter de acoplamiento	1
4	NC / NS	• Cache accouplement	• Coupling housing	• Schutzdeckel	• Cárter de acoplamiento	2
5	NC / NS	• Vis	• Screw	• Schraube	• Tornillo	2
6	NC / NS	• Rondelle	• Washer	• Mutter	• Arandela	4
*7	144 130 019	▪ Kit accouplement	▪ Coupling kit	▪ Kupplungskit	▪ Kit de acoplamiento	1
8	NC / NS	• Axe	• Axe	• Achse	• Eje	1
9	NC / NS	• Goupille	• Pin	• Splint	• Pasador	2
*10	144 130 022	▪ Support mural	▪ Pump bracket	▪ Wandhalterung, kpl.	▪ Soporte de bomba	1
11	NC / NS	• Support mural	• Pump bracket	• Wandhalter	• Soporte de bomba	1
12	NC / NS	• Vis H 6x16	• Screw, model H 6x16	• Schraube, H 6x16	• Tornillo, tipo H 6x16	3
13	NC / NS	• Rondelle AZ6	• Washer, model AZ6	• Mutter, AZ6	• Arandela, tipo AZ6	1
-	144 130 195	Kit écrous, vis et tirants	Nuts, screws and tie-rods kit	Stehbolzen, Schraube und Mutter	Kit tuercas, tornillos y tirantes	1
-	NC / NS	▪ Erou	▪ Nut	▪ Mutter	▪ Tuerca	4
-	NC / NS	▪ Vis	▪ Screw	▪ Schraube	▪ Tornillo	8
-	NC / NS	▪ Tirant	▪ Tie-rod, connecting	▪ Stehbolzen	▪ Tirante	4
15	905 160 101	Raccord coudé F 1/2 JIC - M 1/2 JIC	Elbow connector, F 1/2 JIC - M 1/2 JIC	Winkelnippel IG 1/2 JIC - AG 1/2 JIC	Racor acodado, H 1/2 JIC - M 1/2 JIC	1
16	905 270 913	Raccord coudé 1/4G - T 8x10	Elbow connector 1/4G - T 8x10	Winkel Stecknippel 1/4G - T 8x10	Racor acodado 1/4G - T 8x10	1
17	903 090 806	Robinet FF 1/4	Valve, model FF 1/4	Absperrhahn IG/IG 1/4	Válvula, tipo HH 1/4	1
18	906 314 203	Raccord (inox 316L) MM 1/4 BSP	Fitting, double male, 1/4" (316L stainless steel)	Doppelnippel AG 1/4" - AG 1/4" (Edelstahl, 316L)	Racor (inox 316L) MM 1/4 BSP	1
19	149 596 050	Canne d'aspiration Ø 16	Suction rod Ø 16	Saugschlauch Ø 16	Caña de aspiración Ø 16	1
25	149 596 052	Crépine Ø 16	Strainer Ø 16	Siebkorb Ø 16	Piña Ø 16	1
-	050 450 651	Tuyau produit (Ø 4,8 mm, long. 0,6 m, raccords inox, 240 bar)	Fluid hose (3/16" dia, 0,6 m long, stainless steel hoses, 240 bar / 3481 psi)	Materialschlauch (Ø 4,8 mm, Länge: 0,6 m, Anschlüsse Edelstahl, 240 bar)	Tubería producto (Ø 4.8 mm, 0,6 m de largo, racores de inox, 240 bar)	1

ACCESSOIRES - ACCESSORIES - ZUBEHÖR - ACCESORIOS

Ind	#	Désignation	Description	Bezeichnung	Denominación	Qté
-	149 990 020	Flacon de lubrifiant T (125 ml)	T lubricant (125 ml / 4.4 oz)	Spülmittel T (125 ml)	Botella de lubricante T (125 ml)	1

* Pièces de maintenance préconisées.

* Preceding the index number denotes a suggested spare part.

* Bezeichnete Teile sind empfohlene Ersatzteile.

* Piezas de mantenimiento preventivas.

N C : Non commercialisé.

N S : Denotes parts are not serviceable.

N S : Bezeichnete Teile gibt es nicht einzeln, sondern nur komplett .

N S : no suministrado.

PU 3000

PU 3000



SAMES KREMLIN
150, avenue de Stalingrad
93245 STAINS

Schema electrique et pneumatique Pneumatic and electrical diagram

PU 3000

PU 3000



SAMES KREMLIN
150, avenue de Stalingrad
93245 STAINS

Schema électrique Electrical diagram

N° D'AFFAIRE : 055 680 031

Dessiné le : 15/12/2008

Modifié le : 11/06/2019

Par : DEMESY

Bordereau : 12099

Bordereau Modif :

Indice : H

10 FOLIO

A B C D E F G H I J K L M N O P Q R S T U V W X Y

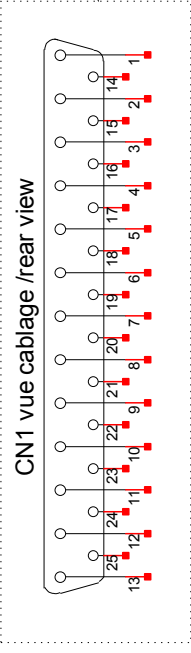
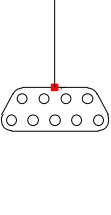
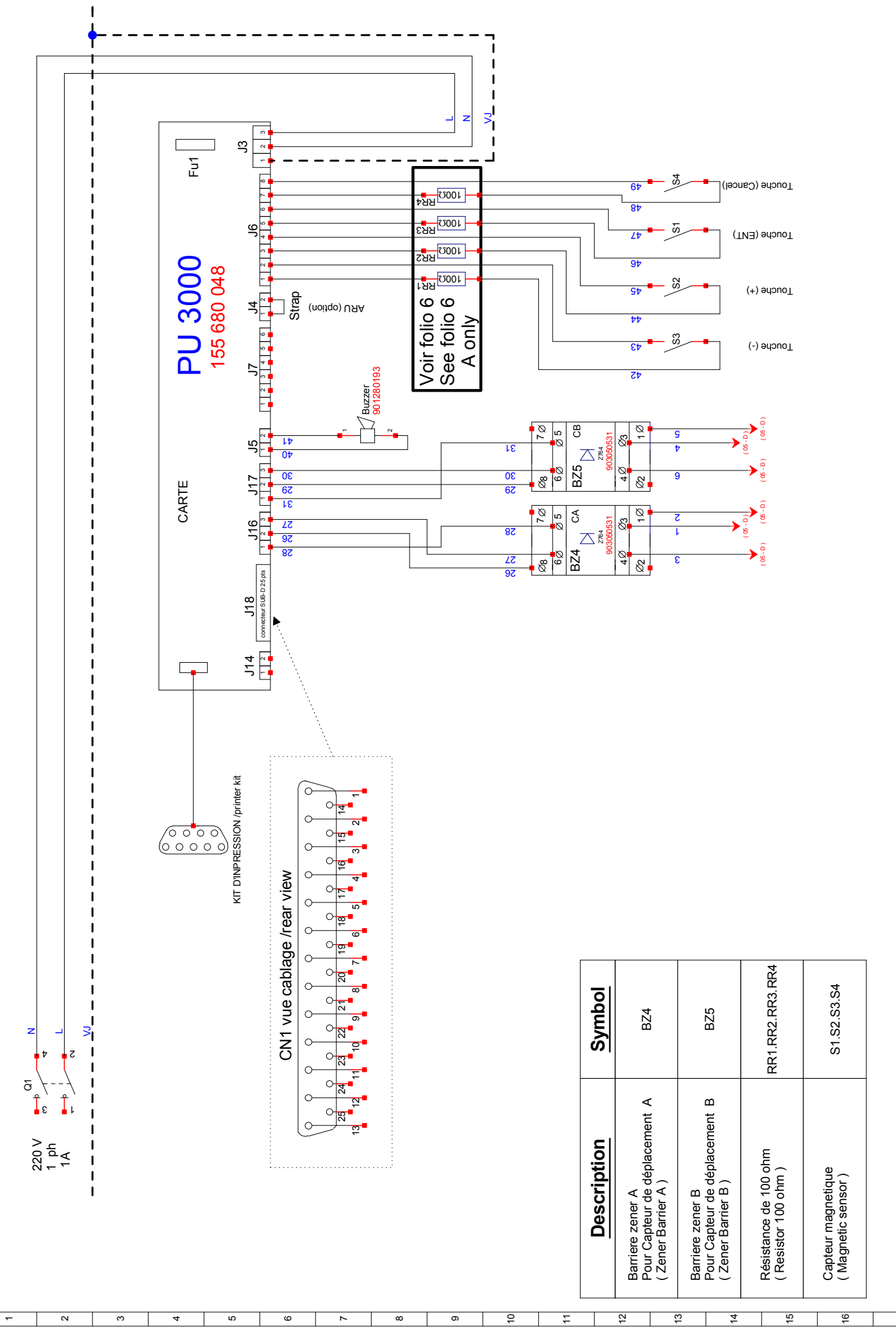

Voir folio 6
See folio 6
A only

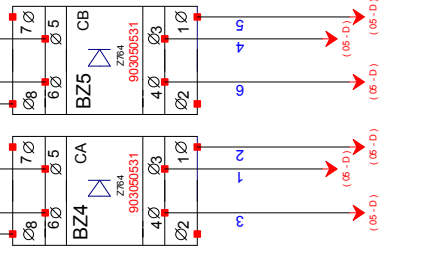

Description	Symbol
Barriere zener A Pour Capteur de déplacement A (Zener Barrier A)	BZ4
Barriere zener B Pour Capteur de déplacement B (Zener Barrier B)	BZ5
Résistance de 100 ohm (Resistor 100 ohm)	RR1.RR2.RR3.RR4
Capteur magnetique (Magnetic sensor)	S1.S2.S3.S4

A B C D E F G H I J K L M N O P Q R S T U V W X Y

SUB D25	Description
1	+24V
2	0V
14	IN
15	+24V
16	0V
3	IN
6	0V
18	+24V(OUT) EV1 VP2A (BZ1)
9	0V
21	+24V(OUT) EV5 MP A
10	0V
22	+24V(OUT) EV4 MP B
7	0V
19	+24V(OUT) EV2 VP2B (BZ2)
8	0V
20	+24V(OUT) EV3 VP3A (BZ3)
11	IN
23	+24V
12	0V
24	+24V(OUT) Option Machine en production (Production Mode enabled)
13	0V
25	+24V(OUT) Option Machine en default (Default/Alarm)

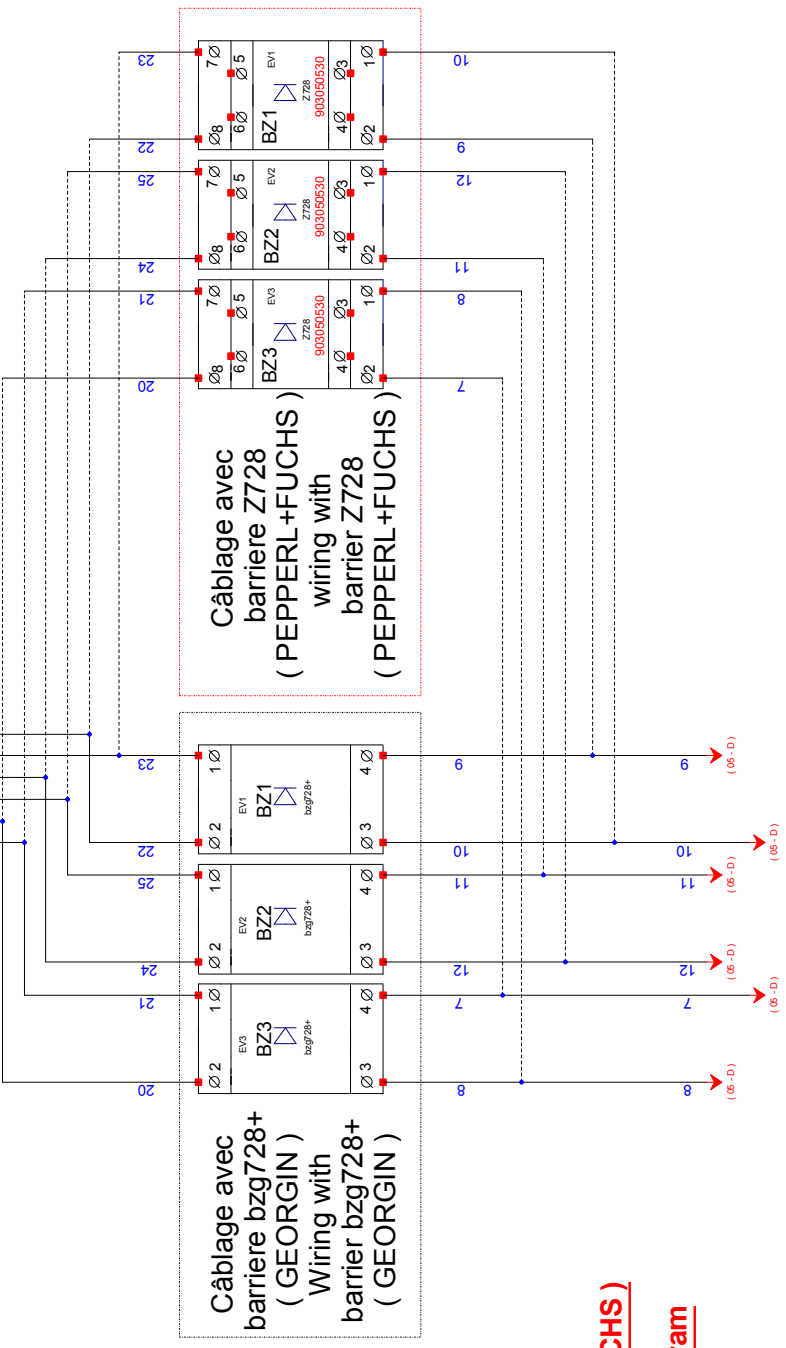
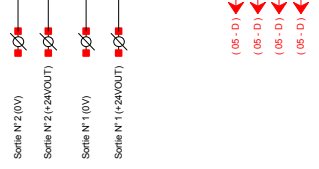
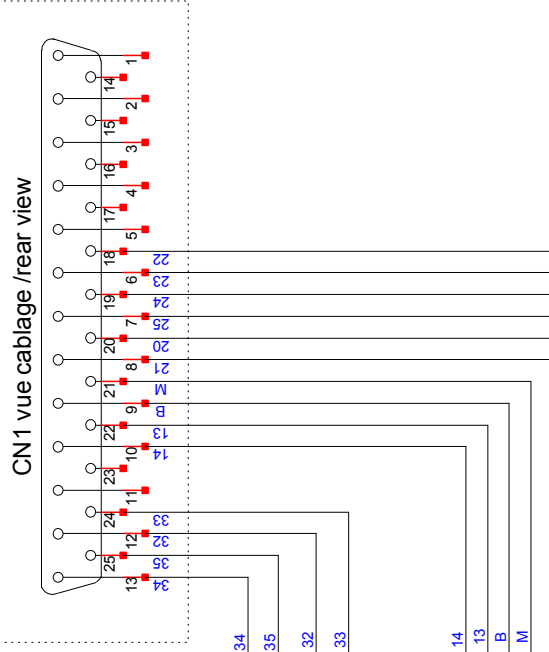
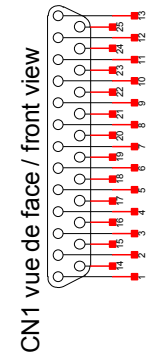

**Le câblage avec barriere bzg728+ (GEORGIN)
et le câblage avec barriere Z728 (PEPPERL+FUCHS)
l'un annule l'autre
For IS barrier you need to select the wiring diagram
depending of IS barrier used**

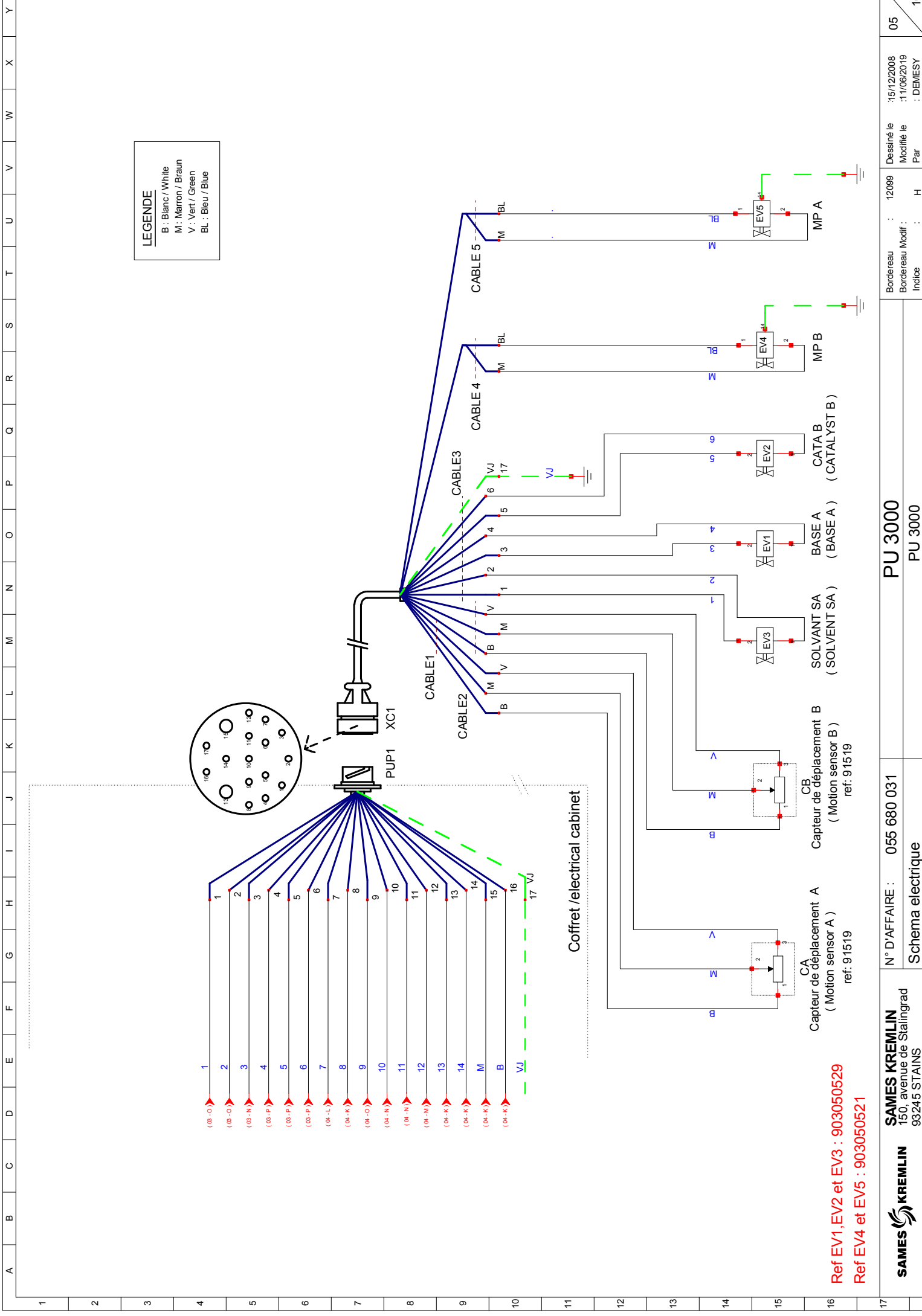

LEGENDE
 B : Blanc / White
 M : Marron / Braun
 V : Vert / Green
 BL : Bleu / Blue

Ref EV1, EV2 et EV3 : 903050529
 Ref EV4 et EV5 : 903050521

A

Ancienne carte Electronique
 Sans led et résistance
 Electronic board
 Without DEL resistor

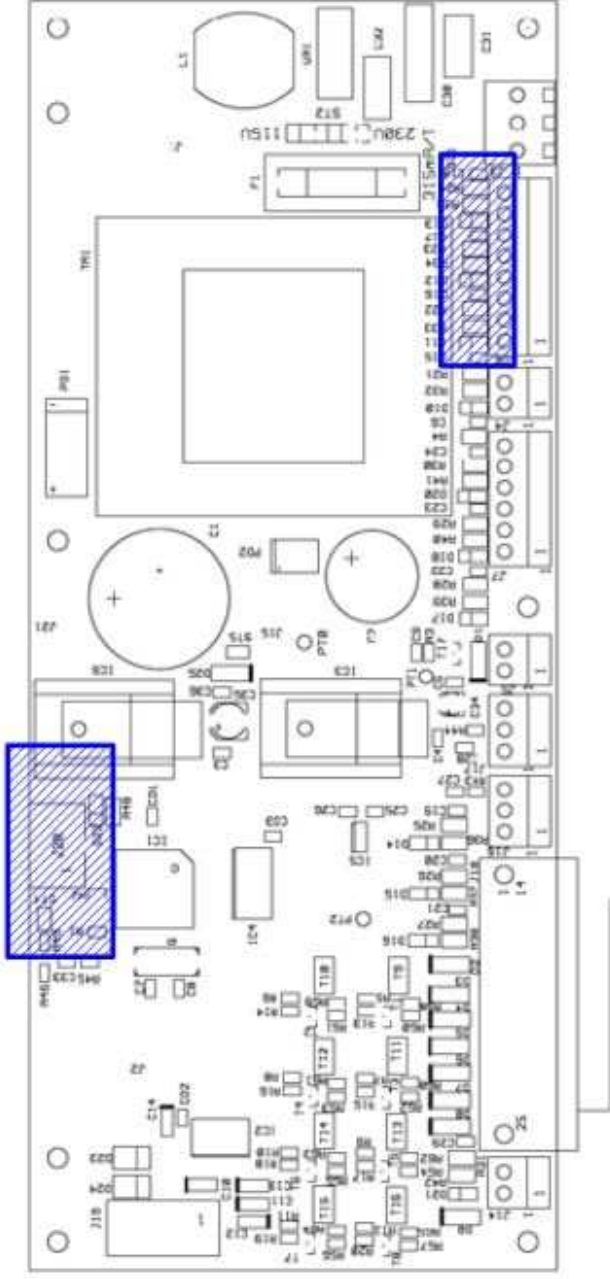

B

Nouvelle carte Electronique
 Avec led et résistance
 New electronic board
 With DEL resistor

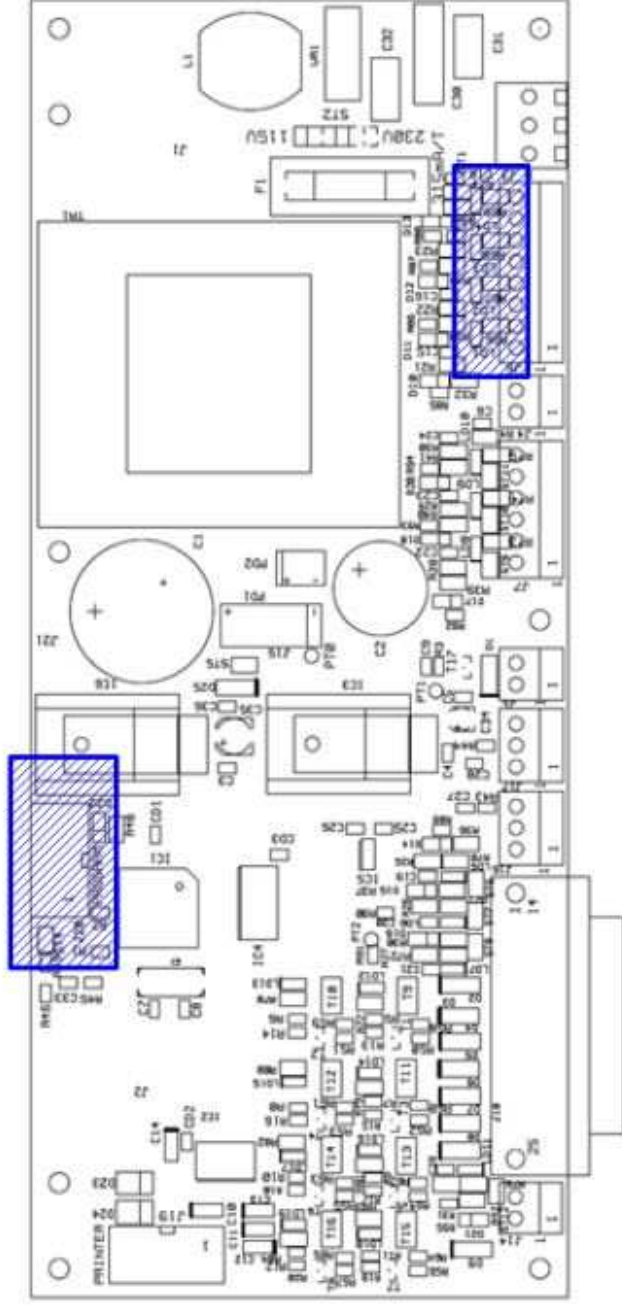

A B C D E F G H I J K L M N O P Q R S T U V W X Y

1 2 3 4 5 6 7 8 9 10 11 12 13 14 15 16 17

SAMES KREMLIN 150, avenue de Stalingrad 93245 STAINS	N° D'AFFAIRE : 055 680 031	PU 3000	Dessiné le : 15/12/2008 Modifié le : 11/06/2019	06
	Schema électrique	PU 3000	Bordereau : 12099 Bordereau Modif : Ince :	Par : H : DEMESY

PU 3000

PU 3000



SAMES KREMLIN
150, avenue de Stalingrad
93245 STAINS

Schema pneumatique Pneumatic diagram

N° D'AFFAIRE : 055 680 031

Dessiné le : 15/12/2008

Modifié le : 11/06/2019

Par DEMESY

Bordereau : 12099

Bordereau Modif :

Indice : H

10 FOLIO

A B C D E F G H I J K L M N O P Q R S T U V W X Y

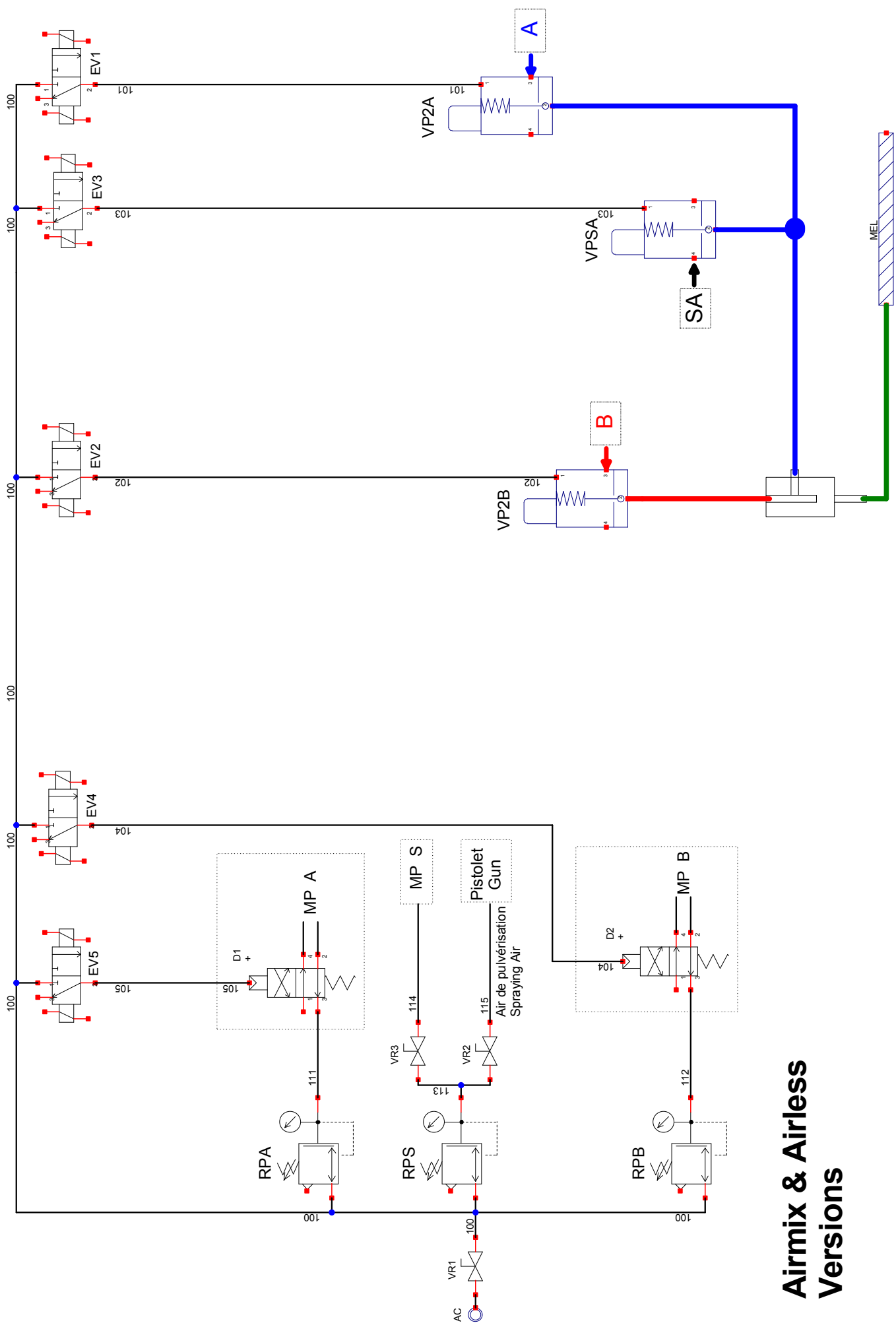

Airmix & Airless Versions

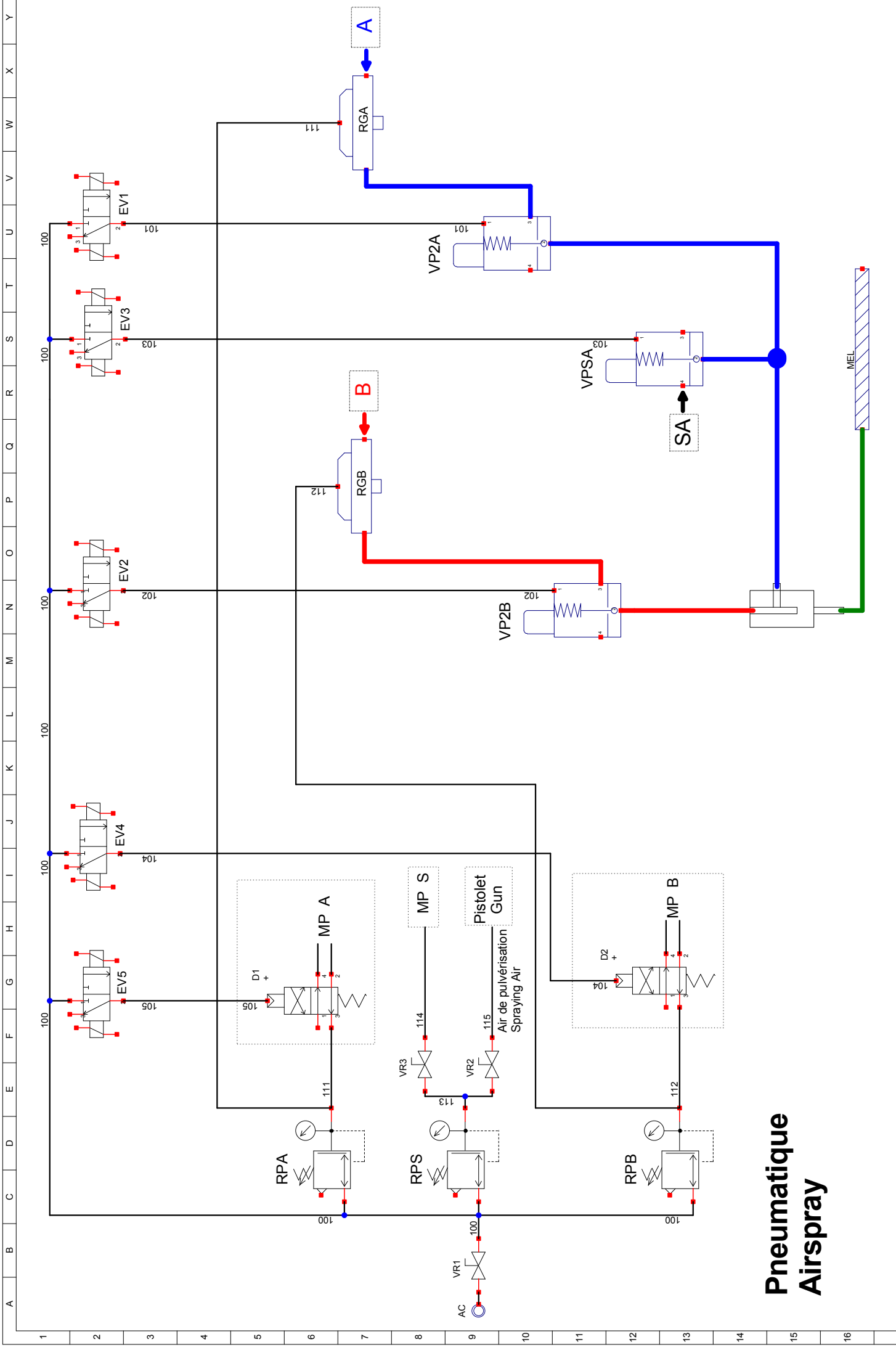

Pneumatique Airspray

A B C D E F G H I J K L M N O P Q R S T U V W X Y	1 2 3 4 5 6 7 8 9 10 11 12 13 14 15 16 17	SAMES KREMLIN 150, avenue de Stalingrad 93245 STAINS	N° D'AFFAIRE : 055 680 031 Schema pneumatique	PU 3000 PU 3000	Dessiné le : 15/12/2008 Modifié le : 11/06/2019 Par : DEMESY	Bordereau : 12099 Bordereau Modif : Ince : H	09 10
					Bordereau : 12099 Bordereau Modif : Ince : H	09 10	

A B C D E F G H I J K L M N O P Q R S T U V W X Y

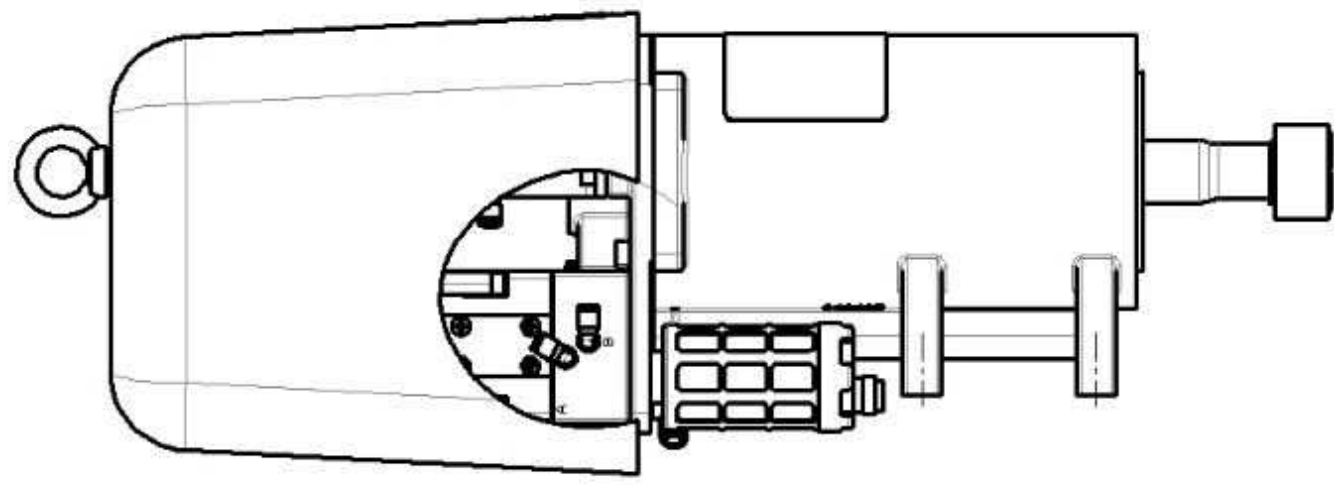

Pneumatique Airspray

1 2 3 4 5 6 7 8 9 10 11 12 13 14 15 16 17